

VRF City Multi Product Catalogue



Air conditioning is an ideal way of controlling the temperature, movement and cleanliness of air inside any building, large or small. With today's buildings being so well insulated and increasingly full of electronic equipment, the need for effective climate control is greater than ever. Not only does it provide heating during winter months, but air conditioning can also cool during summer, doing away with the need for separate heating/cooling systems altogether. More and more people today are enjoying the benefits of comfortable working and living environments made possible with air conditioning.

Contents

Features of Mitsubishi Electric Air Conditioners	p.3-20
Outdoor Unit	p.21-83
Indoor Unit	p.85-138
Controls	p.139-163
Optional Parts	p.164-167
Installation Information	p.168-173
Maintenance Equipment	p.174
BS Salt Protection Specifications	p.175

Our Latest Technologies

VRF system

VRF stands for Variable Refrigerant Flow. A VRF air conditioning system modulates the flow of refrigerant depending upon the capacity requirements of the building. In its simplest form, a VRF system comprises an air-cooled outdoor unit and a series of indoor units that regulate the air temperature inside an internal space.

Intelligent Power Module (IPM) technology

The CITY MULTI range from Mitsubishi Electric provides precise control of energy input, through utilisation of its Intelligent Power Module (IPM) technology. By employing this technology, highly efficient operation is possible with compact units closely matching building requirements.

Inverter driven technology

At Mitsubishi Electric we strive to continually meet the increasing demands of our customers, being the first in the industry to offer highly advanced 'inverter driven' systems. Using inverter technology our systems produce just the right amount of output to match the exact requirement of any building. These systems work so efficiently that they don't waste valuable energy by over-heating or over-cooling, resulting in greatly reduced running costs. Alternative systems that may appear cheaper, can often cost substantially more to run, making Mitsubishi Electric an overall cost effective option.

R410A refrigerant

As scientific evidence points to man-made chemicals for the damage caused to the ozone layer, we only use chlorine-free refrigerants that are safe with zero ODP (Ozone Depletion Potential). Accordingly, our systems require less energy to run, and have a significantly lower indirect global warming potential. In short, we produce the most efficient equipment possible, while helping to protect the environment.

Unsurpassed air conditioning from Mitsubishi Electric

Known the world over, the Mitsubishi brand is a trusted household name associated with a variety of products and services. Founded in 1920, the company known today as Mitsubishi Electric quickly rose to the forefront of the air conditioning industry - a position we still enjoy today. We pride ourselves on offering some of the most energy efficient systems available on the market.

The New EP-YKB/EP-YLM Series



New Technology (PUHY/PURY-EP-Y(S)LM-A(-BS) only)

The world-first*¹ flat-tube heat exchanger significantly improves heat exchange performance achieving high EER/COP and high air-conditioning capacity.

Conventional Heat Exchanger

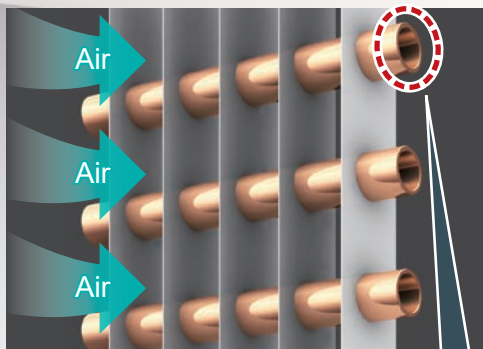

Conventional Tube Shape

Flat-tube Heat Exchanger

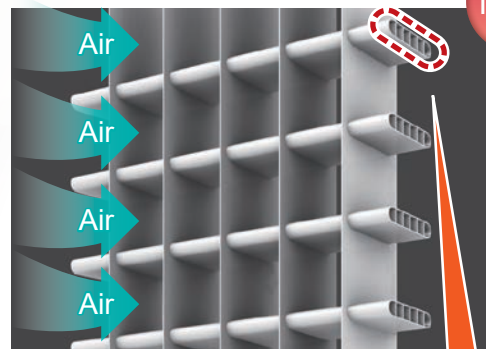

(Illustration)

New Flat Tube

The heat exchanger of the outdoor unit has been drastically changed. Our new model uses a world-first*¹ aluminum flat-tube heat exchanger in the outdoor unit. The flat tubes can reduce airflow resistance, and a larger number of tubes can be installed into the flat-tube heat exchanger when compared to our conventional heat exchanger, greatly increasing the surface area that is in contact with the refrigerant, and greatly improving the heat exchange performance. Our new air conditioner can therefore operate at higher EER/COP and maintain the required cooling/heating capacity.

Energy Saving (PUHY/PURY-EP-Y(S)LM-A(-BS) only)

Lowest power consumption achieves industry-leading energy efficiency.



The new YLM series features various advanced technologies including the world-first*¹ flat-tube heat exchangers, optimum distribution of refrigerant, high efficiency compressor and DC fan motors.

Comparison of EER and COP (between PUHY-EP-YJM-A and PUHY-EP-YLM-A)

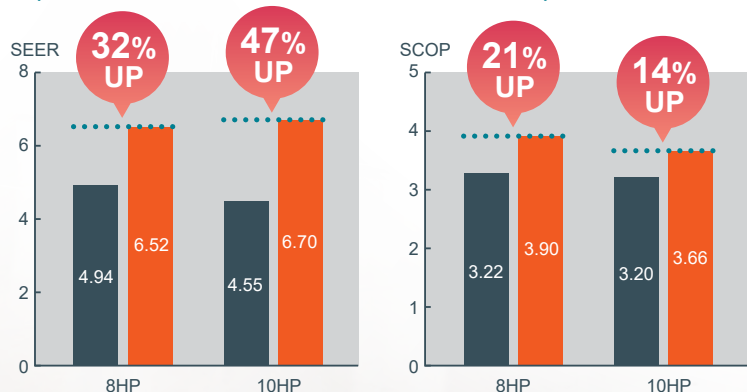

*1: As of October 2013 (according to our own survey); for VRF systems

New Technology

Equipped with High Efficiency Compressor

Optimising the capacity of the scroll compressor and modifying the winding of the compressor motor have led to the improvement in operating efficiency by approximately 2 to 7% during low-load operation that can occur often in actual use.

Relationship between Compressor's Frequency and Efficiency

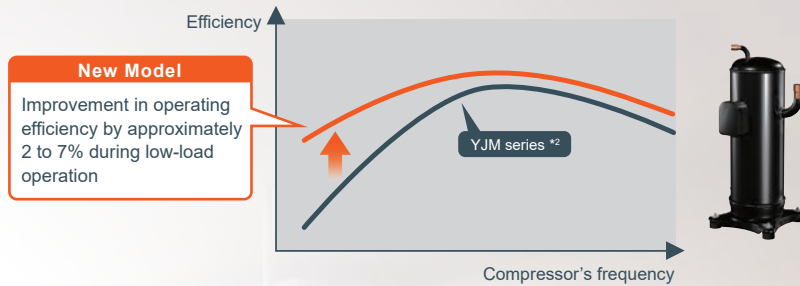

Flexibility of Design

(PUHY-P-Y(S)KB-A(-BS)/PUHY-EP-Y(S)LM-A(-BS))

The new model can work in cooling mode effectively at high ambient temperature.

Enhancement in performance of the actual installation environment of the outdoor unit - expands the cooling operation temperature range up to the ambient temperature of 52°C.

Summer temperatures caused by global warming should be a matter of concern when designing air conditioners. Besides, the outdoor unit may undergo higher intake temperature than the ambient temperature due to the higher temperature exhaust air from it. Higher intake air temperature to the outdoor unit may reduce the cooling capacity of the air conditioner.

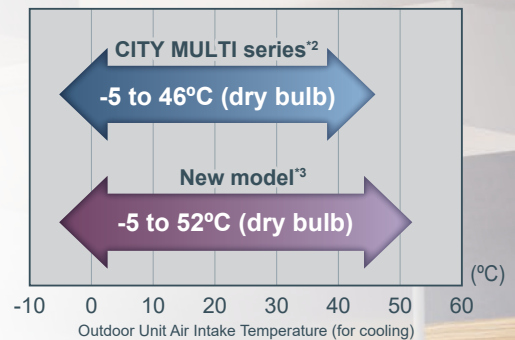

Reliability

(PUHY/PURY-EP-Y(S)LM-A(-BS) only)

Less refrigerant required to be charged on site.*

With our new flat-tube heat exchanger the amount of refrigerant to be charged on site can be controlled and reduced. For example, when the total refrigerant piping length is 150m, the amount of refrigerant to be charged on site can be reduced by approximately 10% compared to our conventional models, achieving reduction in cost and time of the construction work.

*In the case of liquid pipe ø19.05

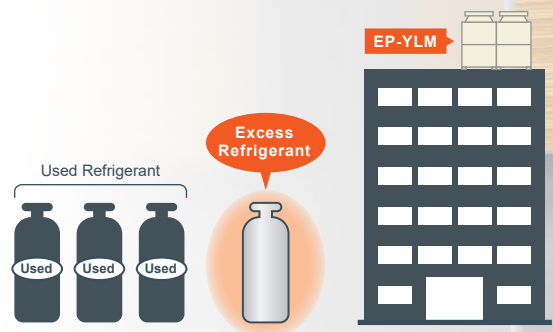

New Technology

(PUHY-EP-Y(S)LM-A(-BS) only)*2

Optimum Distribution of Refrigerant Using a BSC Circuit

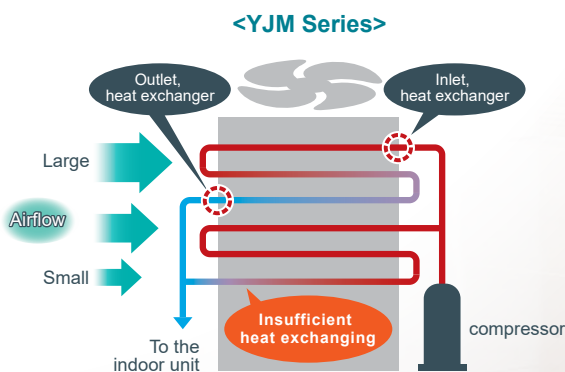

The uniform distribution of the gas-liquid two-phase refrigerant flow throughout the heat exchanger resulted in insufficient heat exchanging at the lower part of the heat exchanger where the airflow is reduced.

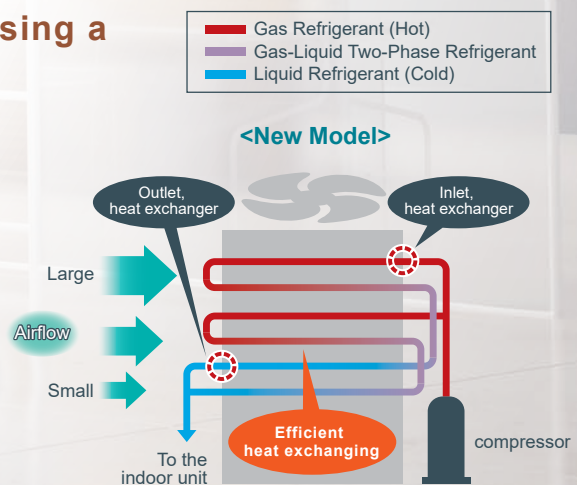

At the upper part of the heat exchanger where the airflow is larger, the gas-liquid two-phase refrigerant which has a large cooling capacity is evenly distributed. This function leads to efficient use of the unit's heat exchanging capacity.

*2: Except for EP300 and EP350 models

The New PQHY/PQRY Series



Increased capacities of single-module units and WR2 units

Single or combination-module units are available to meet various installation conditions and capacity requirements.

Conventional model

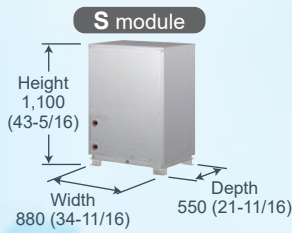

New model

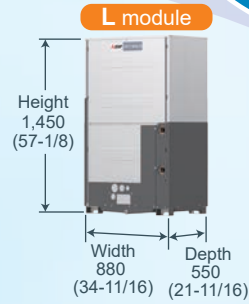
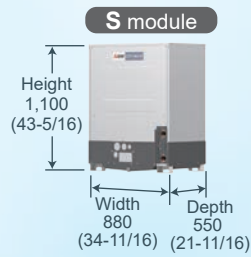

mm (in.)

<WY series>

Newly available single-module units

		P200	P250	P300	P350	P400	P450	P500	P550	P600	P650	P700	P750	P800	P850	P900
NEW	PQHY-P Y(S)LM-A	Single	S	S	S	L	L	L	L	L						
	PQHY-P Y(S)HM-A	Single	S	S	S											
NEW	PQHY-P Y(S)LM-A	Combination				S+S	S+S	S+S	S+S	S+S		L+L	L+L	L+L	L+L	L+L
	PQHY-P Y(S)HM-A	Combination				S+S	S+S	S+S	S+S	S+S	S+S+S	S+S+S	S+S+S	S+S+S	S+S+S	S+S+S

<WR2 series>

Newly available single-module units

Increased capacities up to P900

		P200	P250	P300	P350	P400	P450	P500	P550	P600	P650	P700	P750	P800	P850	P900
NEW	PQRY-P Y(S)LM-A	Single	S	S	S	L	L	L	L	L						
	PQRY-P Y(S)HM-A	Single	S	S	S											
NEW	PQRY-P Y(S)LM-A	Combination				S+S	S+S	S+S	S+S	S+S		L+L	L+L	L+L	L+L	L+L
	PQRY-P Y(S)HM-A	Combination				S+S	S+S	S+S	S+S	S+S						

Improved EER and COP

Greatly improved EER and COP as compared to previous models

Comparisons of new and old single-module P300 units

PQHY-P300YHM-A
 NEW PQHY-P300YLM-A

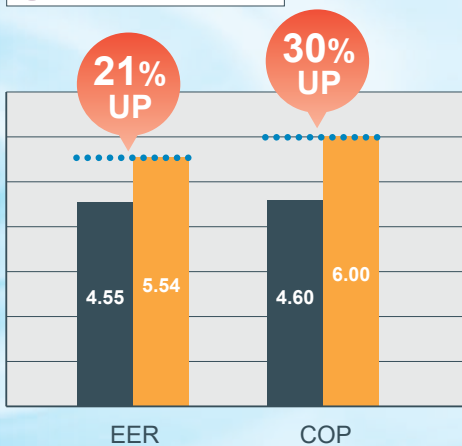

Comparisons of new and old combination-module P600 units

PQHY-P600YSHM-A
 NEW PQHY-P600YSLM-A

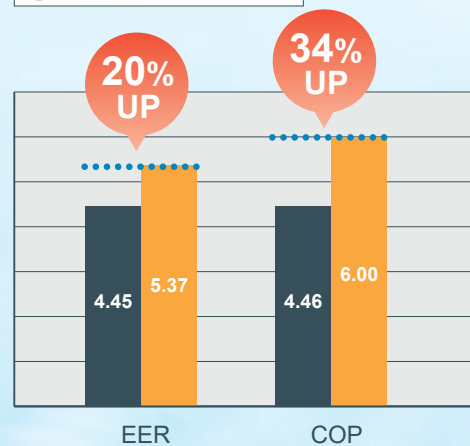

Advantages of increased capacity of single-module units

Reduced piping work

Capable of covering up to P600 (24 HP) with a single module.

■ P400YSHM (WY/WR2 series)

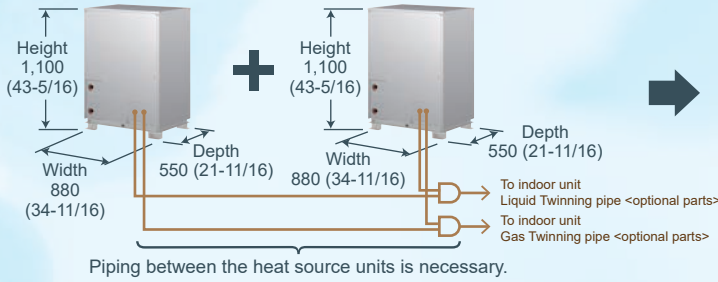

■ P400YLM (WY/WR2 series)

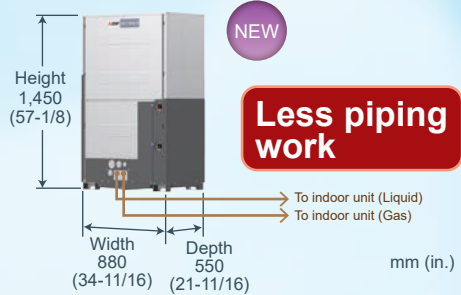

Reduced footprint

Footprint is reduced not only for single-module units but also for combination-module units.

■ PQHY-P YSHM-A

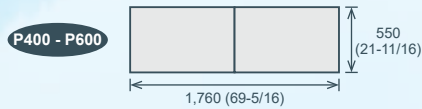

■ PQHY-P Y(S)LM-A

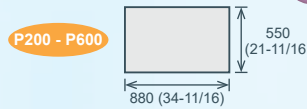

50% reduction

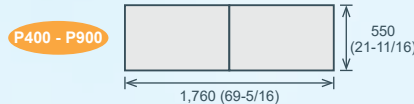
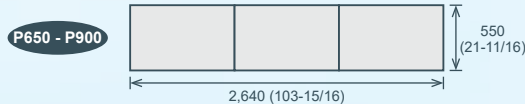

33% reduction

Output signal (0-10V) for water flow rate adjustment controller

Improve system energy consumption by reducing the water pump consumption by changing water flow volume during partial load.

- Control of water flow rate
- Control output voltage (0-10V) for adjustment of valve operating [0V: Full open, 10V: close]
- Voltage at 0 volt: Even when power down, water will continue to circulate.

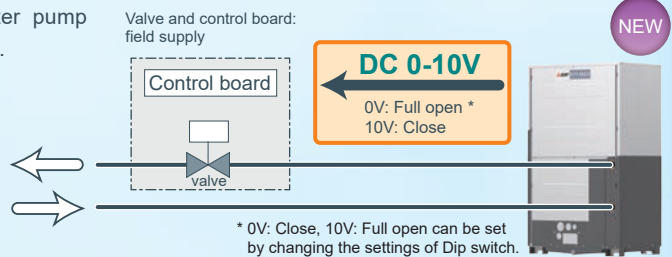

* 0V: Close, 10V: Full open can be set by changing the settings of Dip switch.

Light weight

Unit : kg [lbs]

		P200	P250	P300	P350	P400	P450	P500	P550
PQHY	Y(S)HM	195 [430]	195 [430]	195 [430]	-	390 [860]	390 [860]	390 [860]	390 [860]
	Y(S)LM	174 [384]	174 [384]	174 [384]	217 [479]	217 [479] *1	348 [768]	217 [479] *1	348 [768] *2
PQRY	Y(S)HM	181[400]	181[400]	181[400]	-	362 [800]	362 [800]	362 [800]	362 [800]
	Y(S)LM	172 [380]	172 [380]	172 [380]	216 [477]	216 [477] *1	344 [760]	216 [477] *1	344 [760] *2

		P600	P700	P750	P800	P850	P900
PQHY	Y(S)HM	390 [860]	585 [1290]	585 [1290]	585 [1290]	585 [1290]	585 [1290]
	Y(S)LM	246 [543] *1	348 [768] *2	434 [958]	434 [958]	434 [958]	434 [958]
PQRY	Y(S)HM	362 [800]	-	-	-	-	-
	Y(S)LM	246 [543] *1	344 [760] *2	432 [954]	432 [954]	432 [954]	432 [954]

*1: Single module

*2: Combination module

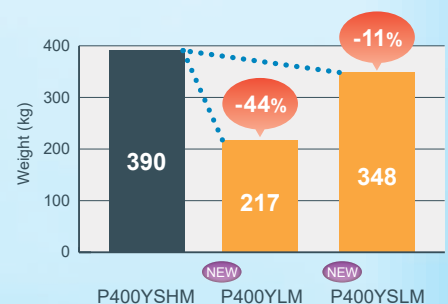



Sophisticated Yet Simple Technology

Reliable

Designed and manufactured to the highest standards, the CITY MULTI range offers one of the most reliable air conditioning systems available. Simple to install and easy to maintain, this range provides ideal solutions you can trust to protect your investment.

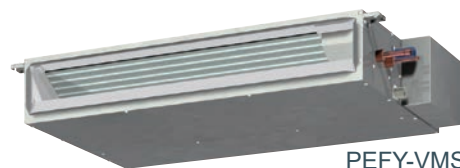

PEFY-VMS1

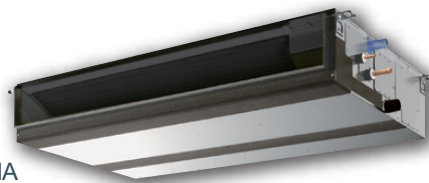

PEFY-VMA



PFFY-VKM

VRF Systems

Our Answer to VRF

Mitsubishi Electric sets the boundaries of VRF technology with the CITY MULTI range, which is available using R410A refrigerant with zero ODP (Ozone Depletion Potential). The range has been specifically designed for today's building requirements and addresses key market issues such as energy efficiency, adaptability and reliability. With user friendly control systems utilising internet technology and integrated cooling and ventilation indoor units, CITY MULTI is the benchmark and market leader in VRF technology.

VRF is a multi and direct expansion type air conditioning system whereby one outdoor unit can be connected with multiple indoor units. The amount of refrigerant can be regulated freely according to the load on the indoor unit by the inverter driven compressor in the outdoor unit. Zoning in a small office is possible with a small capacity indoor unit. Energy conservation is easily handled because individual indoor units can stop and start their operation as needed. There are various indoor units available in order to suit various interior design needs.

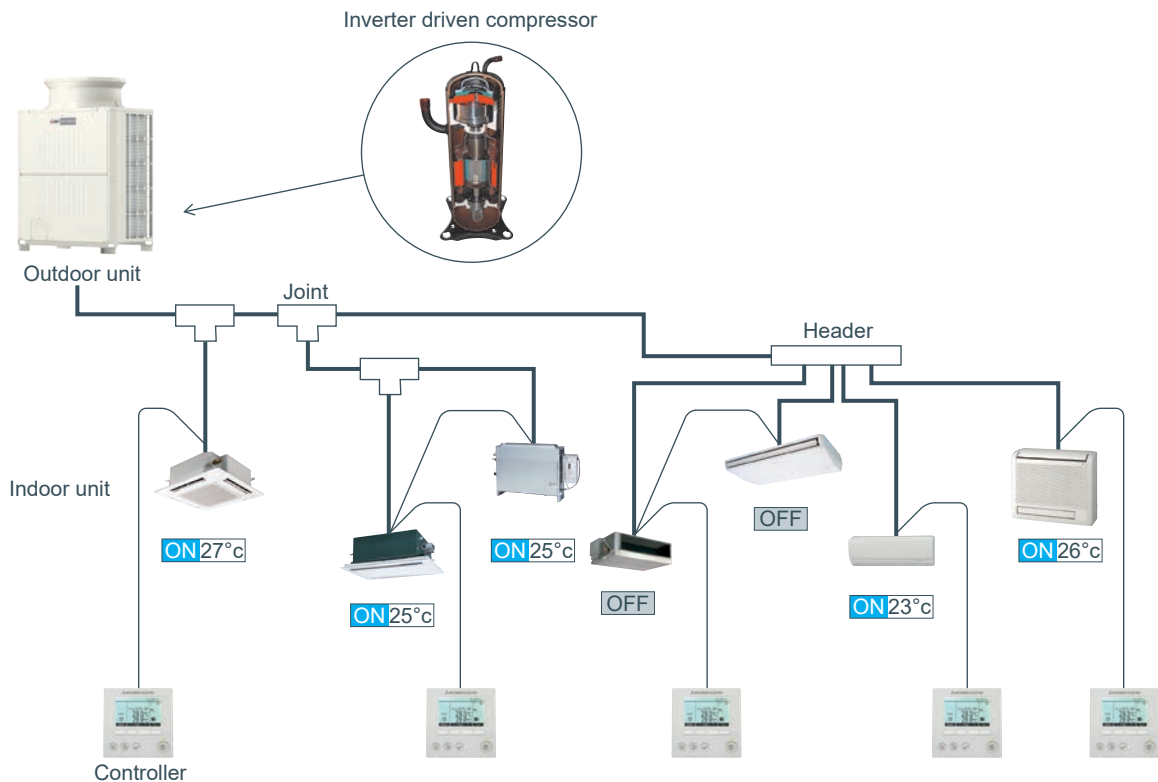



Unbeatable Efficiency

Heat Interchange Circuit

The unique Heat Interchange Circuit (HIC) enhances efficiency by providing additional sub-cooling and allows the expansion device to effectively control the refrigerant distribution, thereby increasing the operating efficiency and reducing the volume of refrigerant in each system.

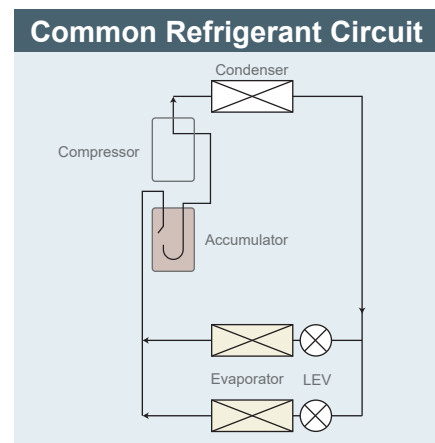
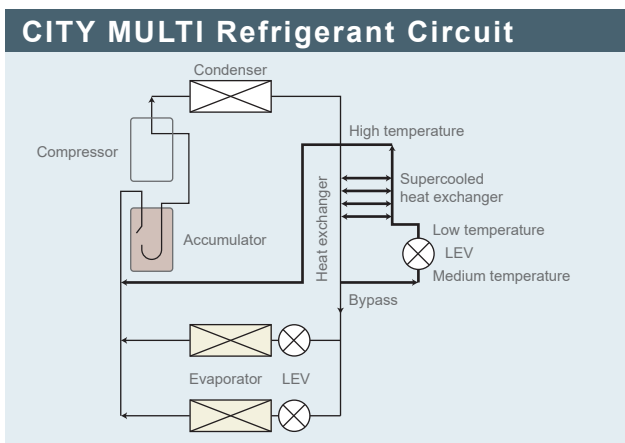

Inverter Driven Compressor Technology



Low Starting Currents

Using inverter driven technology saves energy in several ways:

The compressor varies its speed to match the indoor cooling or heating demand and therefore only consumes the energy that is required.

When an inverter-driven system is operating at partial load, the energy efficiency of the system is significantly higher than that of a standard fixed speed, non inverter system.

The fixed speed system can only operate at 100%, even though partial load conditions prevail for the majority of the time. Therefore, fixed speed systems cannot match the annual efficiencies of inverter-driven systems.

Using proven single inverter-driven compressor technology, the CITY MULTI range is favoured by the industry for its low starting currents (only 8 amps for a 18HP YLM-A outdoor unit) and smooth transition across the range of compressor frequencies.

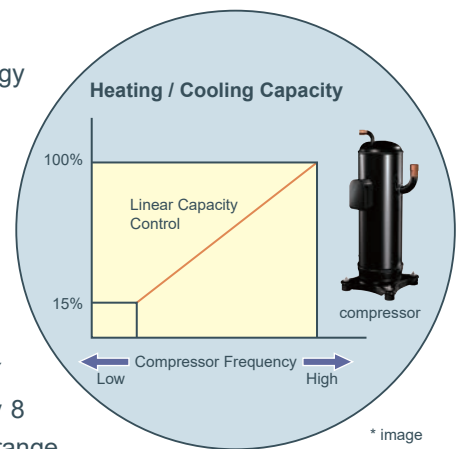

* image

* The values vary depending on the actual conditions such as ambient temperature.

All CITY MULTI compressors are inverter-driven type.

Capable of precisely matching a building's cooling and heating demands (High COP model).

The outdoor unit combinations comprise 1 unit for 8-18HP systems (for Y and R2 series), 2 units for 20-24HP systems (for R2, 20-36HP) and 3 units for 26-54HP systems (Y series only). Each unit carries one inverter compressor making simple and highly reliable control possible.

Not only does it allow low starting currents, the inverter-driven compressor also provides precise indoor comfort and adapts to the air conditioning load.

Stable and Smooth Operation

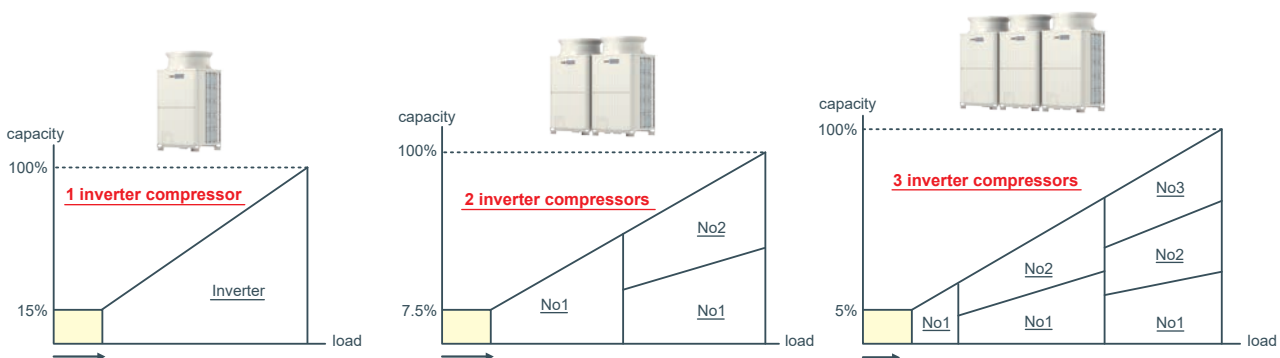



Total Energy Conservation

Comparison of COP (energy efficiency) – 8HP system

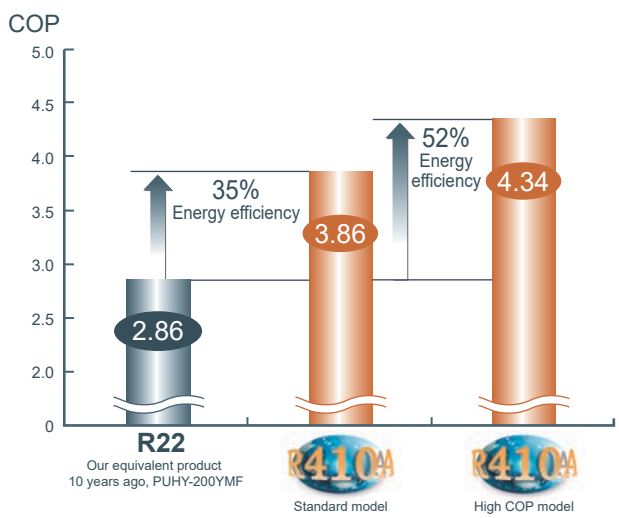

High COP (Coefficient of Performance) is achieved

* Average COP of cooling / heating
* The values were obtained under the standard conditions.

Intelligent Power Module (IPM) Technology

The YLM-A range from Mitsubishi Electric provides precise control of energy input through the utilisation of its Intelligent Power Module (IPM) technology. By employing this technology it is possible to closely match the building requirements, achieving more accurate control of the occupied space. By using incremental 1Hz steps of capacity control, the amount of power input required is significantly reduced, resulting in greatly improved COP's.

In addition, IPM technology ensures effective performance under partial load conditions, a condition that most systems will be in for the majority of the normal working life cycle. By taking into account the efficiency at both part load and peak load conditions, R410A CITY MULTI is designed to provide unbeatable year round/seasonal efficiency.

The Difference between YLM-A and Previous Mitsubishi Electric Models

Technology is the key when increased efficiency is demanded. The CITY MULTI YLM-A range is able to deliver this in simple ways.

Design

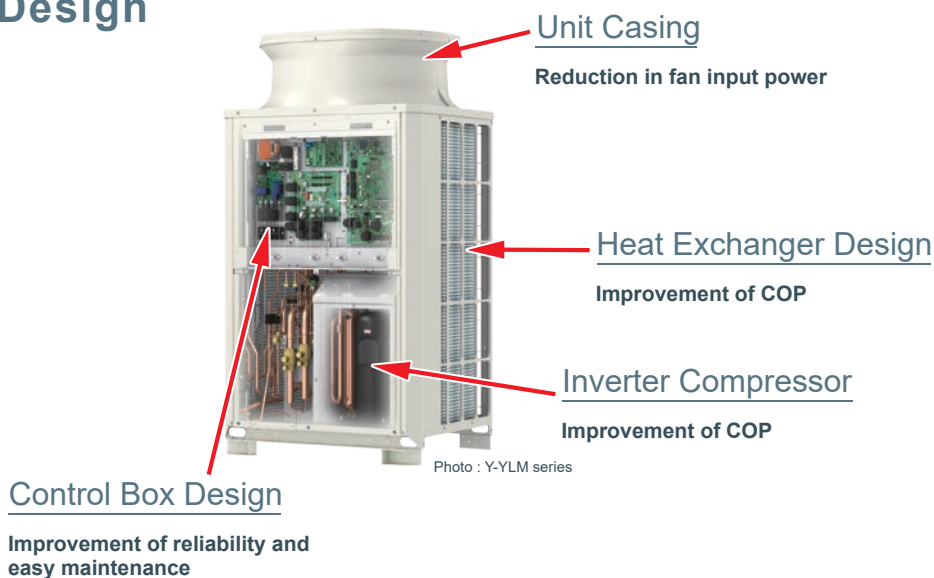

The Importance of COP

COP stands for "Coefficient of Performance". It is a measure of the useful energy a system can deliver compared to the energy it consumes. It is calculated by dividing the energy output by the energy input of a system. The higher the figure then the more efficient the system is deemed to be. Mitsubishi Electric VRF models, the world's highest energy-efficient air-conditioners, will undoubtedly reduce millions of tons of CO₂ emissions.



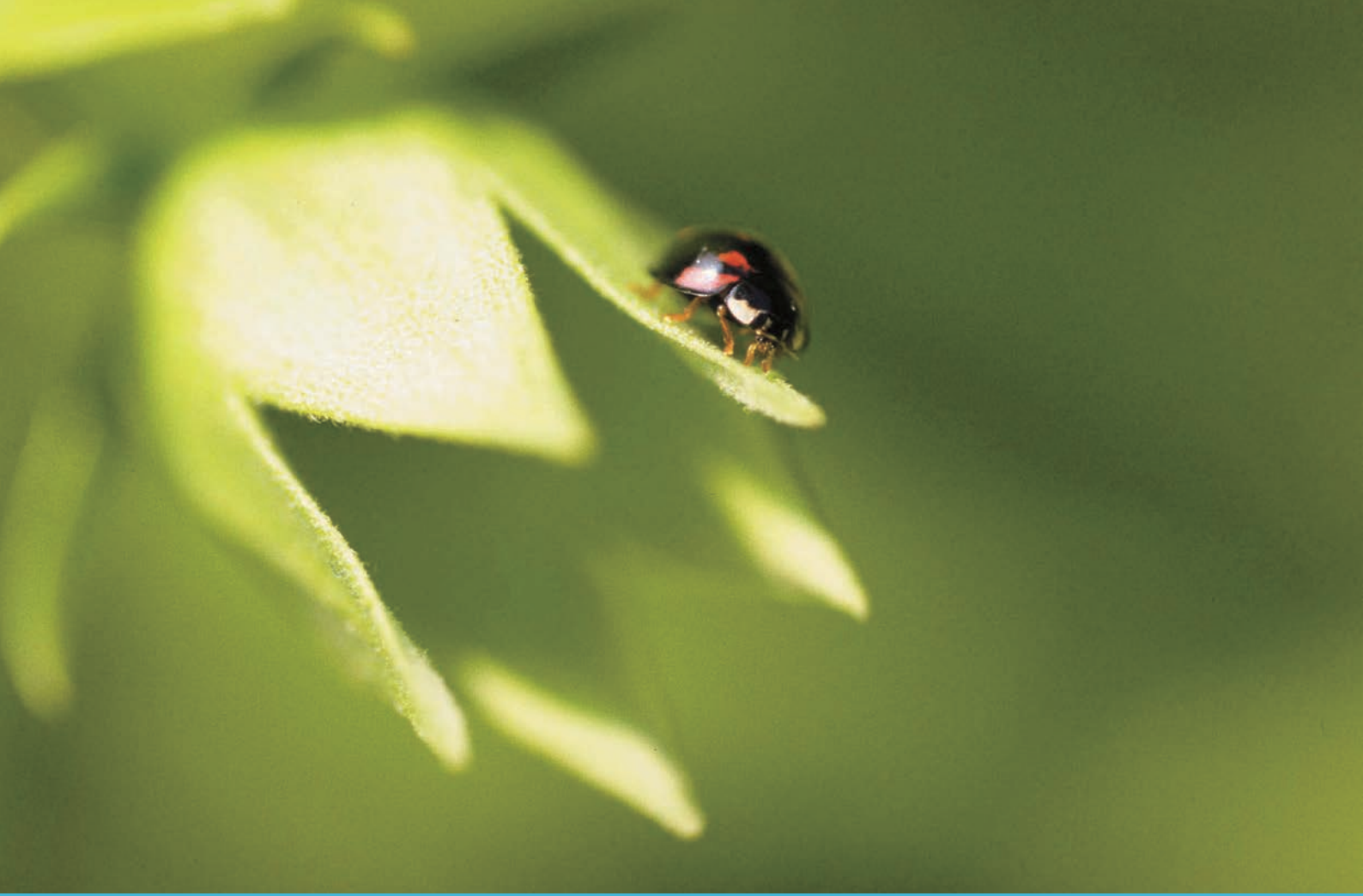

For the Environment

Enhancing Environmental Care

(measures for the RoHS Directive and refrigerant reduction)

Every unit is in compliance with the RoHS Directive,* which stands for the Restriction of Hazardous Substances. Lead-free soldering is used to avoid Lead Groundwater Contamination on the print board. The amount of refrigerant on the unit has also been reduced to enhance environmental care.

* RoHS Directive: the restriction of the use of certain hazardous substances in electrical and electronic equipment that has been sold in EU since July 2006

Efficient R410A Refrigerant



History of Refrigerant

R22, an HCFC-based refrigerant, had been a popular choice for most chillers. However, R22 has been targeted by the Montreal Protocol to be phased out in new equipment. Additionally, governments in many countries are enforcing a ban of HCFC-based refrigerants for new installations.

Because of these restrictions, R410A refrigerants are desirable. R410A is a blend of HFCs, which do not deplete the ozone.

Technical Aspects of Refrigerant

R410A is a more efficient refrigerant as it has a higher specific heat capacity when compared to R407C or R22. This higher energy carrying capacity allows for smaller pipe sizes, longer pipe runs and reduces the volume of refrigerant within a system. This is a major factor when considering safety and environmental requirements in the design, manufacturing, installation, operation, maintenance and disposal of refrigerating systems.

A highly efficient R410A scroll compressor design results in less friction loss at the motor. A simplified refrigerant circuit (low pressure loss) including a new accumulator design also adds a few more points to the efficiency scale. Enhancements to the heat interchange circuit, an inverter-driven fan motor and a heat exchanger design, again add vital increases to overall system efficiencies and COPs.

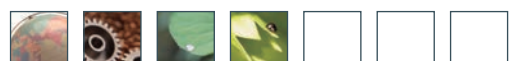

Affordable & Effective

air conditioning you can rely on

Energy efficiency is maximised when the R2 Series is simultaneously heating and cooling

Operation Pattern of CITY MULTI *R2* System

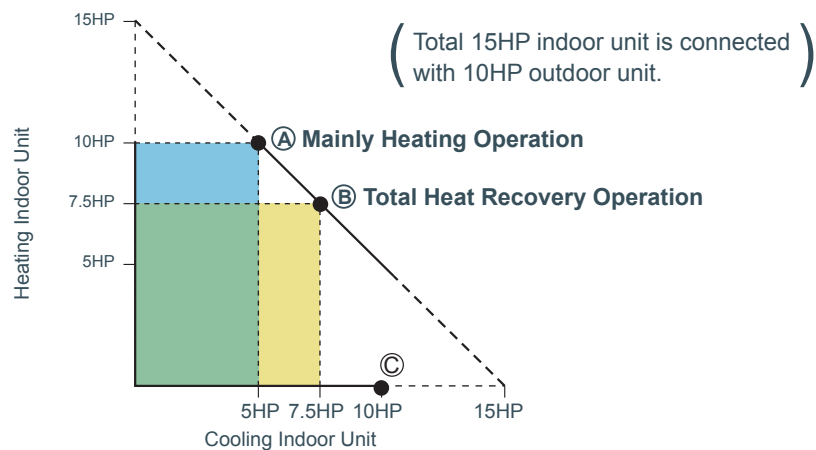

Unique to Mitsubishi Electric

Our heat recovery technology uses just two pipes, as opposed to the market conventional three. Our R2 system, designed for effective simultaneous heating and cooling, offers substantial savings on installation and annual running costs.

Why Heat Recovery?

Flexibility and efficiency are key factors when selecting a heat recovery system. For example, while a heat pump system is adequate for a large open-plan office, an office that has a more partitioned structure will need to simultaneously heat or cool different sections of the office according to each user's individual preferences. The efficiency of this type of system comes from the ability to use the by-products of cooling and heating to transfer energy where it is required, thus acting as a balanced heat exchanger achieving up to 20% cost savings over a conventional heat pump system. The number of connection sites needed for an R2 system are also significantly lower than those needed for a three pipe version. This helps to reduce installation costs, further increasing the savings associated with CITY MULTI.

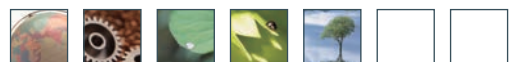
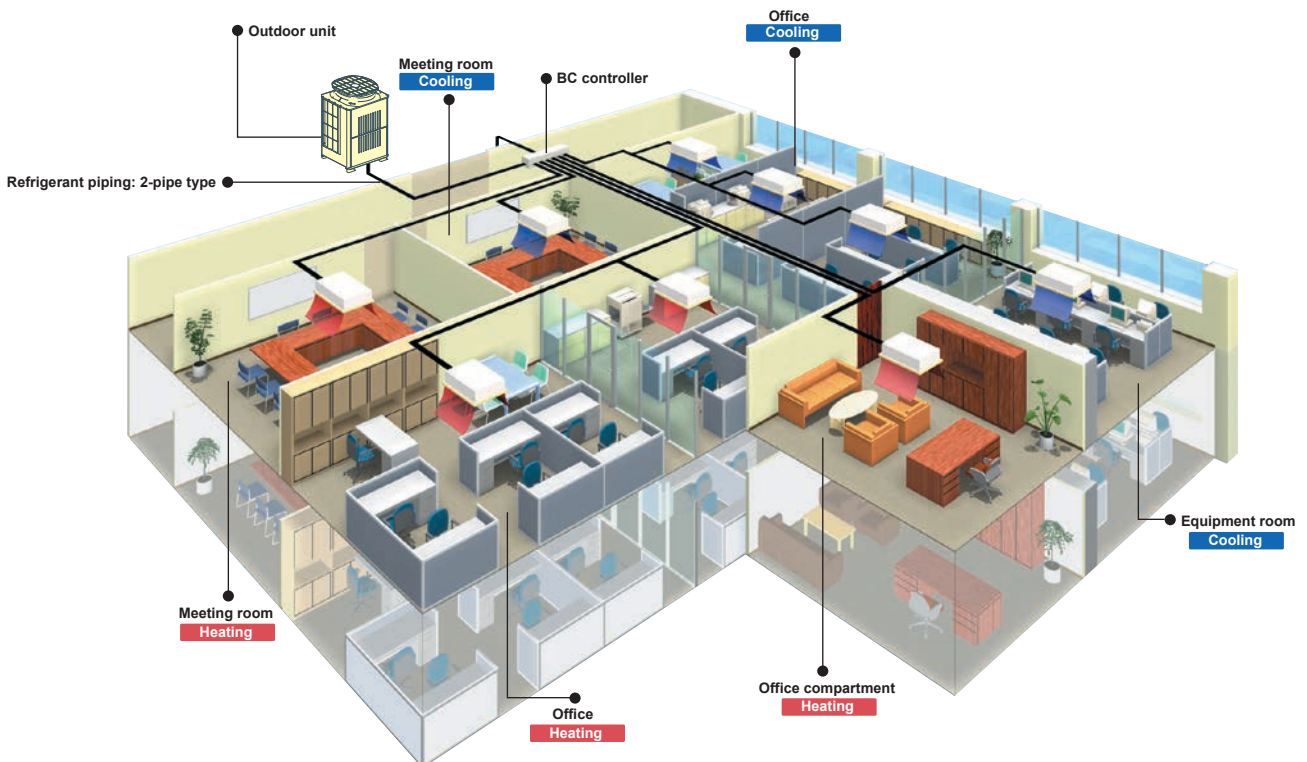



“2-pipe” System Provides Better Efficiency and Performance

Comparison Example of Piping Connection Sites

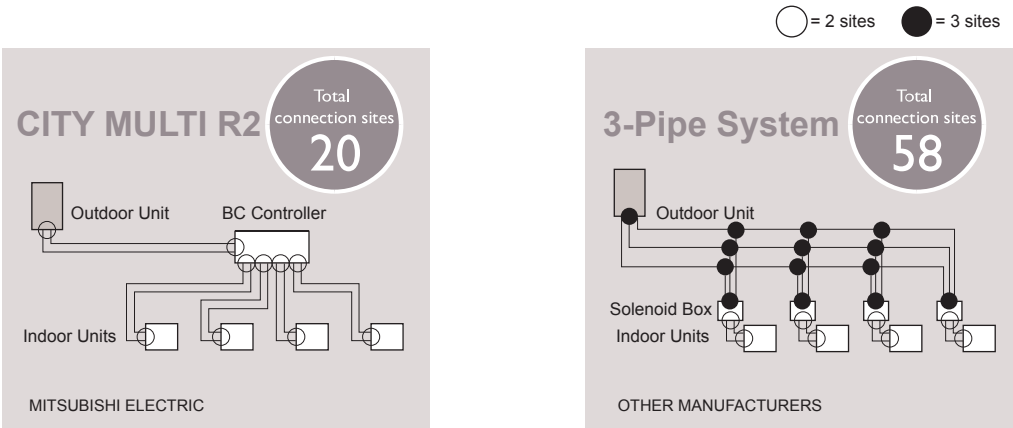

Energy Saving Technology

What is Water-Cooled?

>A unique offering from Mitsubishi Electric

It is possible now to combine the features of VRF with a water circuit using CITY MULTI WR2/WY. In this case the heat is rejected to a water source rather than to the outside air.

The advantages of water cooled systems are that the water can be delivered at optimised temperatures and volumes, which allows even greater flexibility and increased COP.



WR2(Heat recovery type)

Mitsubishi Electric now offers double heat recovery operation.

The first heat recovery is within the refrigerant system. Simultaneous cooling and heating operation is available with heat recovery performed between indoor units.

The second heat recovery is within the water loop, where heat recovery is performed between the PQRV units.

This double heat recovery operation substantially improves energy efficiency and makes the system the ideal solution to the requirements of modern office buildings, where some areas require cooling even in winter.

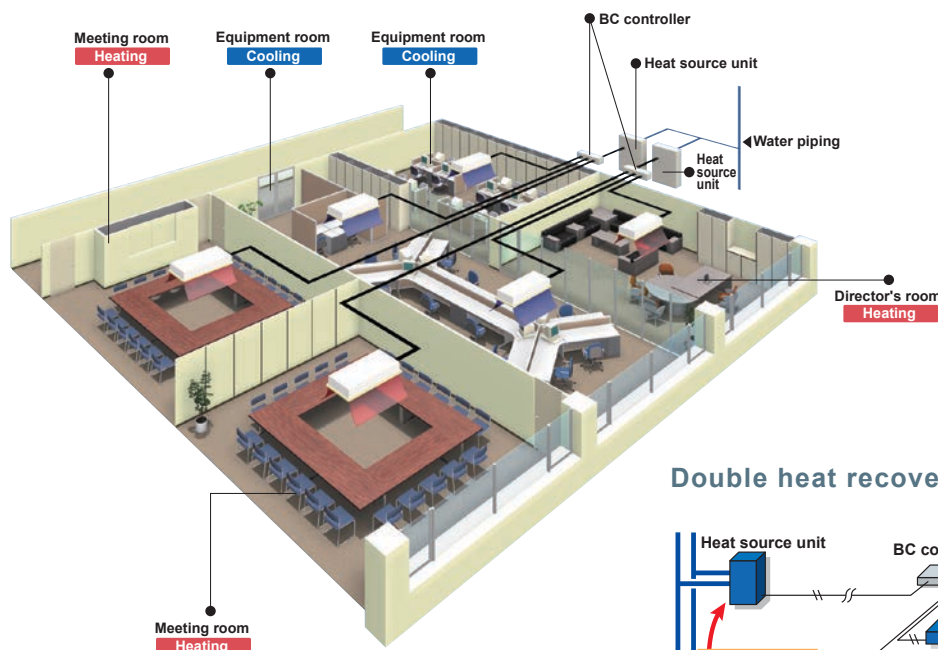

Double heat recovery (WR2)

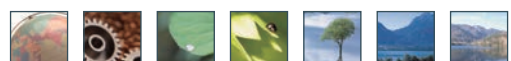
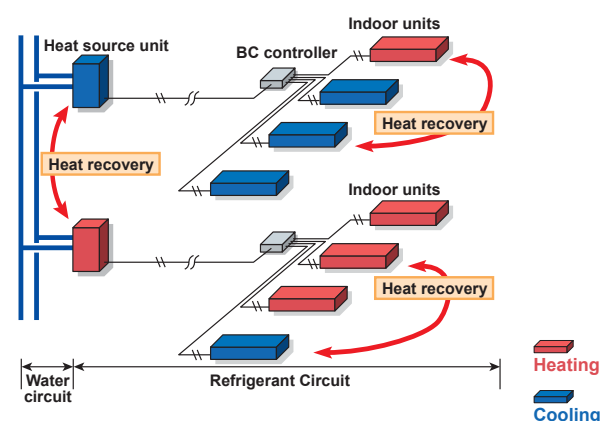

Fit Out Flexibility

Mitsubishi Electric offers the most flexible piping architecture when it comes to tenant fit out flexibility. Using our multiport BC box and refrigerant ball valves on BC box outlets, it is very easy to move/add/modify indoor units. Units can be added or removed without the need for recovering the total refrigerant charge resulting in the rest of the system remaining in operation.

The City Multi BC controller allows us to have spare ports to add additional indoor units at a later date. In most situations, a slave BC controller can also be retrofitted to give additional connections.

MASTER BC

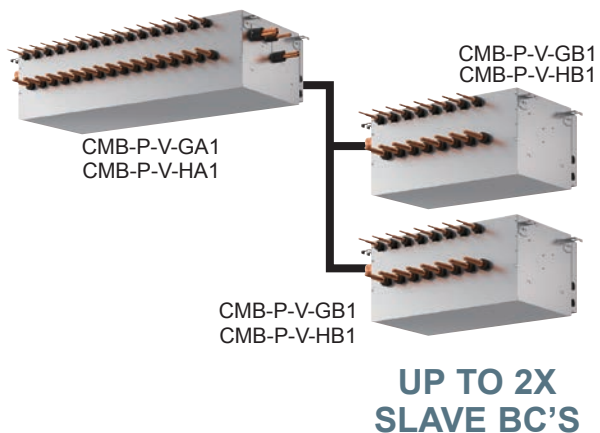

Mitsubishi Electric branch controller fitted with refrigeration ball valves for ease of maintenance and fit out flexibility.

It is very hard to achieve this with a 3 pipe system as the pipework is sized on the current connected load.

All City Multi VRF indoors and BC's are back engineered to ensure the latest products can be installed on VRF systems running on older refrigerants.











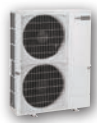









Outdoor Unit

- **Heat Pump Series (S)**
- **Heat Pump Series (Y)**
- **Heat Pump Series - High COP (Y)**
- **Heat Pump Series - Zubadan**
- **Water Cooled Heat Pump Series (WY)**
- **Heat Recovery Series (R2)**
- **Heat Recovery Series - High COP (R2)**
- **Water Cooled Heat Recovery Series (WR2)**



Wide Selection of Outdoor Units

System	Type	Model name	HP Model	4.5	5	6	8	10	12	14	16	
				P112	P125	P140	P200	P250	P300	P350	P400	
Air Cooled	Heat Pump	S series <small>Page 36 - Page 37</small> PUMY-P VKM-A(-BS) PUMY-P YKM-A(-BS) 		4.5	5	6						
		Y series <small>Page 38 - Page 48</small> PUHY-P YKB-A(-BS) PUHY-P YSKB-A(-BS)   	S				8	10			8	8
		L							12	14		
		XL										
		Y series - High COP <small>Page 49 - Page 59</small> PUHY-EP YLM-A1(-BS) PUHY-EP YSLM-A1(-BS)   	S				8	10				
			L							12	14	
	XL										16	
	Heat Recovery	ZUBADAN series <small>Page 66</small> PUHY-HP YHM-A(-BS) PUHY-HP YSHM-A(-BS) (When sold with water module or AHU only.) 	S				8	10			8	8
			L									
			XL									
		R2 series <small>Page 67 - Page 72</small> PURY-P YLM-A(-BS) PURY-P YSLM-A(-BS)   	S				8	10			8	8
			L							12	14	
XL											16	
R2 series - High COP <small>Page 73 - Page 77</small> PURY-EP YLM-A1(-BS) PURY-EP YSLM-A1(-BS)   	S				8	10						
	L							12	14			
	XL									16		
Water Cooled	Heat Pump	WY series <small>Page 60 - Page 65</small> PQHY-P YLM-A PQHY-P YSLM-A  	S				8	10	12			
		L								14	16	
	Heat Recovery	WR2 series <small>Page 78 - Page 83</small> PQRY-P YLM-A PQRY-P YSLM-A  	S				8	10	12			
		L								14	16	

	18	20	22	24	26	28	30	32	34	36	38	40	42	44	46	48	50	52	54
	P450	P500	P550	P600	P650	P700	P750	P800	P850	P900	P950	P1000	P1050	P1100	P1150	P1200	P1250	P1300	P1350
	8 10	10 10	10	10							10								
			12	14	12 14	14 14	14 16	14	16		12 16	12 14	12 16	14 16	14 14	14 16	14	16	
								18	18	18 18					18	18	18 18	18 18	18 18
		10 10	10		8 8 10	8 8	8 10	8	10										
			12	12 12		12	12	12 12	12 12	12 12	12 14	12 12	12 14	14 14	14 14	14	14		
	18											16	16	16	18	16 18	18 18	16 18 18	18 18 18
		10 10																	
	8 10	10 10	10																
			12	12 12	12 14	14 14	14 16	16 16	16										
									18	18 18									
		10 10	10																
			12	12 12	12 14	14 14	14												
	18						16	16 16	16 18	18 18									
	18	20	22	24		14 14	14 16	16 16	16 18	18 18									
	18	20	22	24		14 14	14 16	16 16	16 18	18 18									

Advanced Energy-saving Technologies



S series | PUMY-P VKM
PUMY-P YKM

Highly efficient fan and grille for outdoor unit

The shapes of the fan and grille of the outdoor unit have been redesigned, resulting in an increase in blowing capacity and more efficient heat exchange while maintaining the same operating noise level.

Outdoor unit fan opening increased

The diameter of the opening for the fan in the outdoor unit has been increased from 490 to 550mm. Blowing capacity has been increased while maintaining the same fan rotation speed.

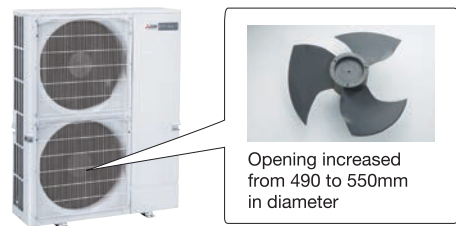

Grille shape changed

The shape of the air outlet grille has been changed to reduce pressure loss. This has helped to improve heat exchange performance.

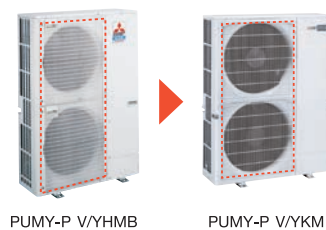

Inflexed fan

Adoption of a fan with improved ventilation characteristics and a newly designed rear edge that suppresses wind turbulence increases fan operation efficiency.

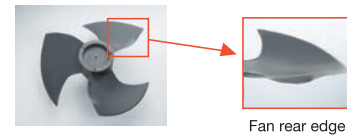

Highly efficient heat exchanger

A high density and increase in surface area have improved the heat-exchange efficiency of the heat exchanger.

High-density heat exchanger

The pipe diameter has been changed from 9.52 to 7.94mm, resulting in a high-density heat exchanger.

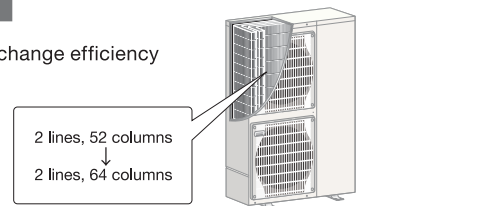

Heat-exchange surface area increased

The heat exchanger size has been extended horizontally, increasing the surface area.

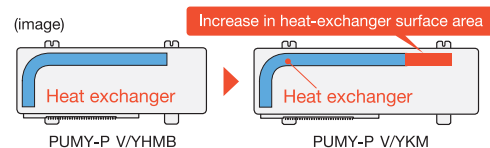

Heat Interchanger (HIC) added

An HIC circuit has been added to improve energy efficiency during cooling operation. Liquid refrigerant is rerouted, transformed into a gas state and injected back into the system to increase overall pressure of the refrigerant being sent to the compressor, thereby reducing the load on the compressor and raising efficiency.

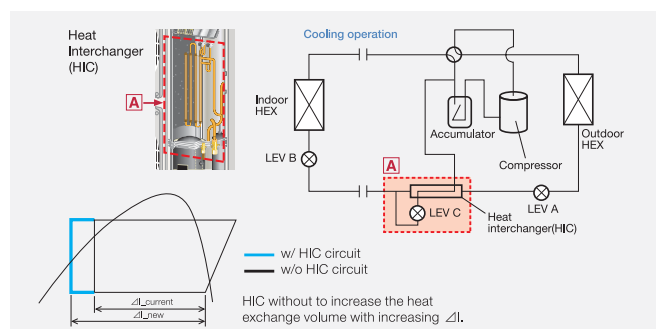

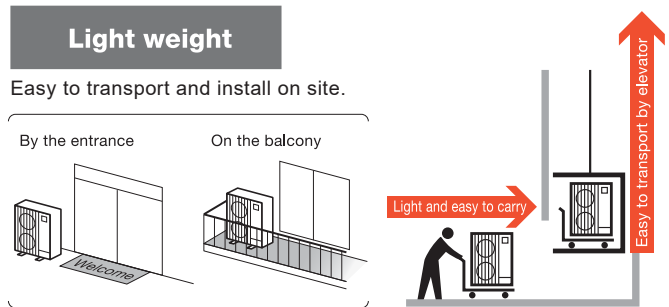

The two-pipe zoned system designed for Heat Pump Operation

The CITY MULTI S series (for small applications) make use of a two-pipe refrigerant system, which allows for system change-over from cooling to heating, ensuring that a constant indoor climate is maintained in all zones. The compact outdoor unit utilises R410A refrigerant and an inverter-driven compressor for greater energy efficiency.

With a wide range of indoor units combined with a flexible piping system, the CITY MULTI series can be configured for all applications. Up to 12 (S series) indoor units can be connected with up to 130% connected capacity to maximise engineer's design options. This feature allows easy air conditioning in each area with convenient individual controllers.

Small Offices

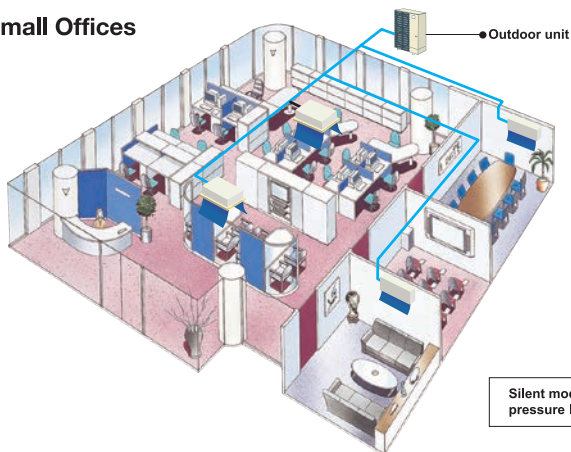

Residence

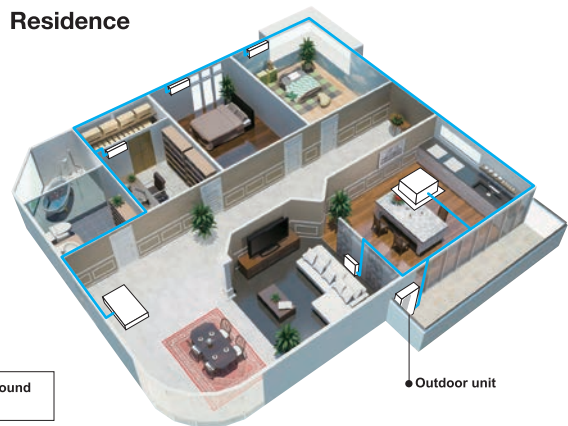

Silent mode can reduce sound pressure level by 3dB(A)

[P112~140(V/YKM)]

Refrigerant Piping Lengths	Maximum meters [Feet]
Total length	300 [984]
Maximum allowable length	150 (175 equivalent) [492(574)]
Farthest indoor from first branch	30 [98]
Vertical differentials between units	Maximum meters [Feet]
Indoor/outdoor (outdoor higher)	50 [164]
Indoor/outdoor (outdoor lower)	40 [131]
Indoor/indoor	15 [49]

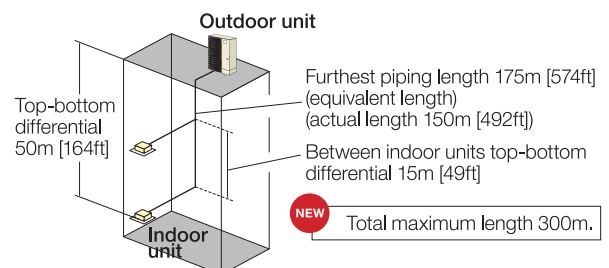

Outdoor Unit

Y (Heat Pump) series



Heating or Cooling

Y series — **PUHY-P YKB-A(-BS)** **PUHY-EP YLM-A(-BS)**
PUHY-P YSKB-A(-BS) **PUHY-EP YSLM-A(-BS)**

The two-pipe zoned system designed for Heat Pump Operation

The CITY MULTI Y series (for large applications) make use of a two-pipe refrigerant system, which allows for system changeover from cooling to heating, ensuring that a constant indoor climate is maintained in all zones. The compact outdoor unit utilises R410A refrigerant and an inverter-driven compressor to use energy effectively. With a wide line-up of indoor units in connection with a flexible piping system, the CITY MULTI series can be configured for all applications. Up to 50 (Y series) indoor units can be connected with up to 130% connected capacity to maximise engineer's design options. This feature allows easy air conditioning in each area with convenient individual controllers.

Large Offices (Y series)

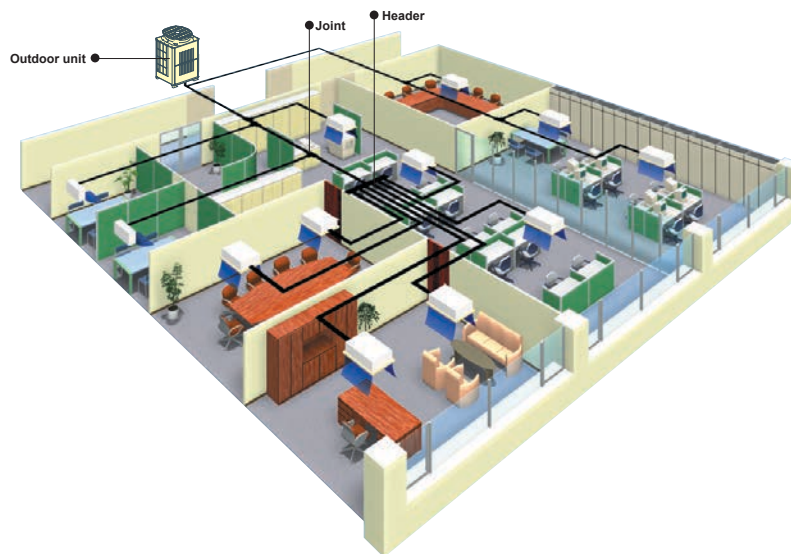

[8-54HP (Y series)]
 [8-54HP (High COP Y series)]

Refrigerant Piping Lengths	Maximum meters [Feet]
Total length.....	1,000 [3,280]
Maximum allowable length.....	165 (190equivalent) [541(623)]
Farthest indoor from first branch.....	40 [131]*1
Vertical differentials between units	Maximum meters [Feet]
Indoor/outdoor (outdoor higher).....	50 [164]*2
Indoor/outdoor (outdoor lower).....	40 [131]*3
Indoor/indoor.....	15 [49]*4

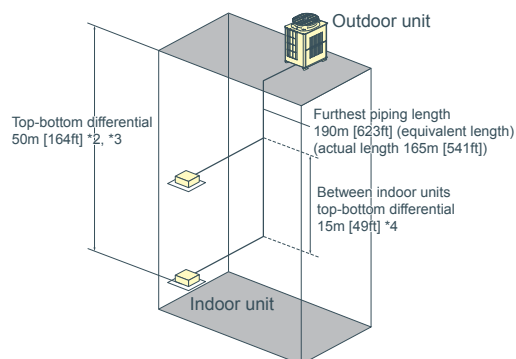

*1 90m [295ft] is available. When the piping length exceeds 40m [131ft], use one size larger liquid pipe starting with the section of piping where 40m [131ft] is exceeded and all piping after that point.
 *2 90m [295ft] is available depending on the model and installation conditions. For more detailed information, contact your local distributor.
 *3 60m [196ft] is available depending on the model and installation conditions. For more detailed information, contact your local distributor.
 *4 30m [98ft] is available. If the height difference between indoor units exceeds 15m [49ft] (but does not exceed 30m [98ft]), use one-size larger pipes for indoor unit liquid pipes.



Outdoor Unit

R2 (Heat Recovery) series



Simultaneous Heating and Cooling

R2 series — **PURY-P YLM-A(-BS)** **PURY-EP YLM-A(-BS)**
PURY-P YSLM-A(-BS) **PURY-EP YSLM-A(-BS)**

The world's first two-pipe system that Simultaneously Heats and Cools

CITY MULTI R2 series offers the ultimate in freedom and flexibility, able to heat one zone while cooling another. Our exclusive BC controller makes two-pipe simultaneous cooling and heating possible. The BC controller is the technological heart of the CITY MULTI R2 series. It houses a liquid and gas separator, allowing the outdoor unit to deliver a mixture of hot gas for heating and liquid for cooling, all through the same pipe. This innovation results in virtually no energy wasted by being expelled outdoors. Depending on capacity, up to 50 indoor units can be connected with up to 150% connected capacity.

Installation image (R2 series)

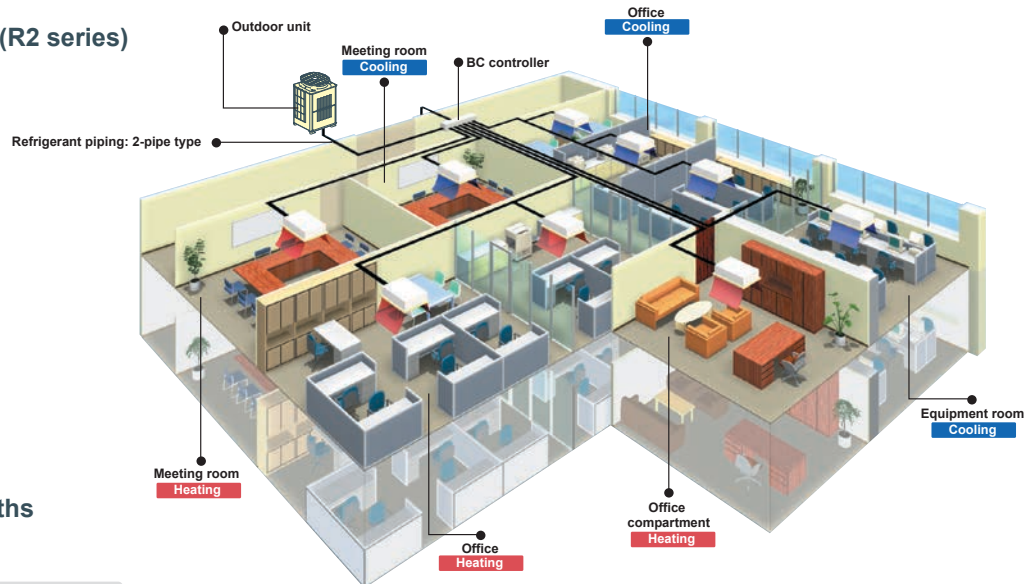

System Pipe Lengths

[8-36HP (R2 series)]
 [8-36HP (High COP R2 series)]

Refrigerant Piping Lengths	Maximum meters [Feet]
Total length.....	550 [1,804]
((E)P600, 650 only)	
Total length.....	700 [2,296]
((E)P700, 750, 800, 850, 900 only)	
Maximum allowable length.....	165 (190equivalent) [541 (623)]
Maximum length between outdoor and single/main BC controller.....	110 [360]
*Maximum total length is dependent upon the distance between the outdoor unit and the single/main BC Controller.	
Maximum length between single/main BC controller and indoor.....	40-60 [131-196]
Vertical differentials between units	Maximum meters [Feet]
Indoor/outdoor (outdoor higher).....	50 [164]*2
Indoor/outdoor (outdoor lower).....	40 [131]*2
Indoor/BC controller (single/main).....	15 [49]
*Maximum length between single/main BC controller and indoor is dependent upon the vertical differential between the single/main BC controller and the indoor unit.	
Indoor/indoor.....	15 [49]
Main BC Controller/Sub BC Controller.....	15 [49]

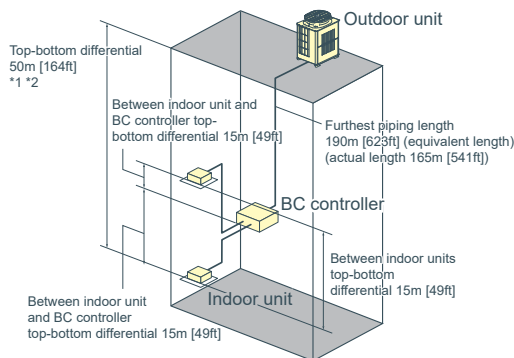

*1 When the outdoor unit is installed below the indoor unit, top-bottom differential is 40m [131ft].

*2 Depending on the model and installation conditions, top-bottom differential 90m [295ft] (o/u above) and 60m [196ft] (o/u below) is available. For more detailed information, please contact your nearest sales office or distributor.





Heating or Cooling

ZUBADAN series — [PUHY-HP YHM-A(-BS)
PUHY-HP YSHM-A(-BS)

Bringing year round comfort solutions to extreme climates

CITY MULTI ZUBADAN series combines the ultimate in application flexibility and powerful cooling and heating capabilities to deliver precise comfort even in the coldest days of the year down to -25°C.

The technology behind this is a Flash Injection Circuit which provides the optimum amount of refrigerant to the system via a compressor through a specially designed injection port to ensure a particularly stable operation. With this, ZUBADAN can provide full heating performance even at -15°C and continuous heating for up to 250 minutes in one continuous cycle, ensuring phenomenal heating performance at low temperatures.

Installation image

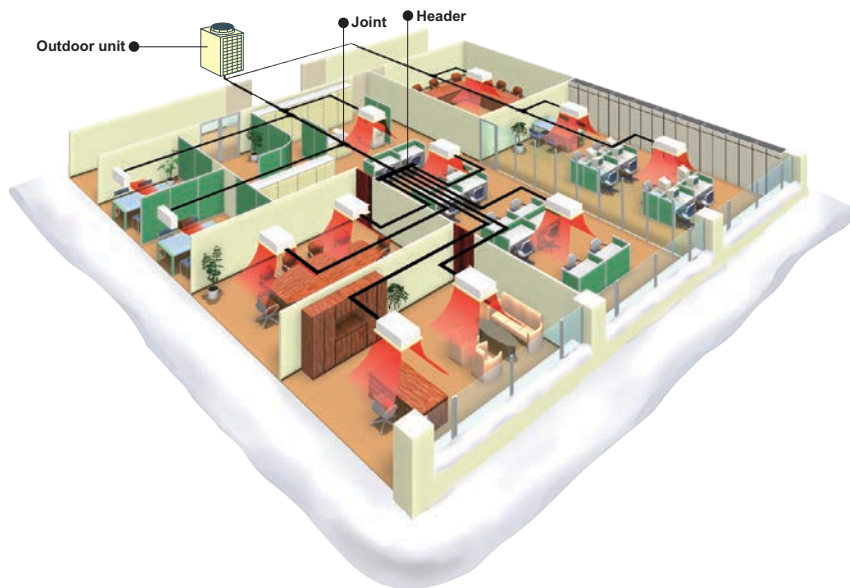

System Pipe Lengths

[8-10HP]

Refrigerant Piping Lengths	Maximum meters [Feet]
Total length.....	300 [984]
Maximum allowable length.....	150 (175equivalent) [492 (574)]
Farthest indoor from first branch.....	40 [131]
Vertical differentials between units	Maximum meters [Feet]
Indoor/outdoor (outdoor higher).....	50 [164]
Indoor/outdoor (outdoor lower).....	40 [131]
Indoor/indoor.....	15 [49]

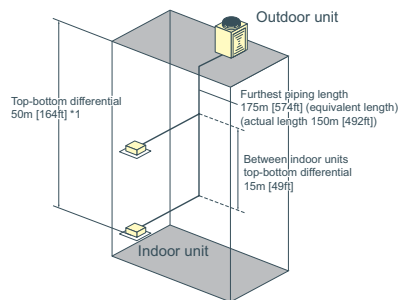

*1 When the outdoor unit is installed below the indoor unit, top-bottom differential is 40m [131 ft].



Outdoor Unit

Stable Heating Performance even at -15°C

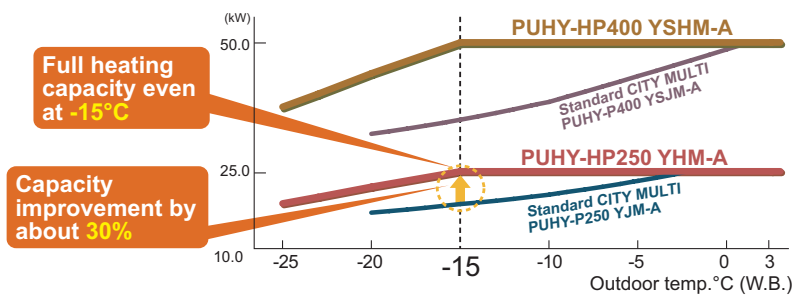

Using an industry first 'Flash-injection Circuit', the ZUBADAN System is able to provide FULL heating performance in ambient temperatures as low as -15°C.

Expanded Heating Operation down to -25°C

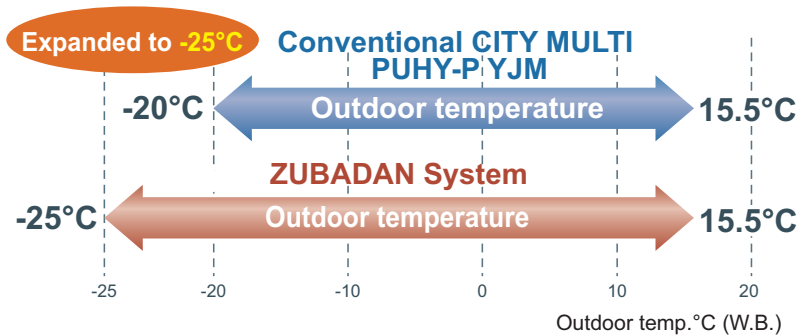

From a previous LOWEST operating ambient temperature of -20°C, the ZUBADAN System pushes the boundaries of technology to give heating in ambient temperatures as low as -25°C.

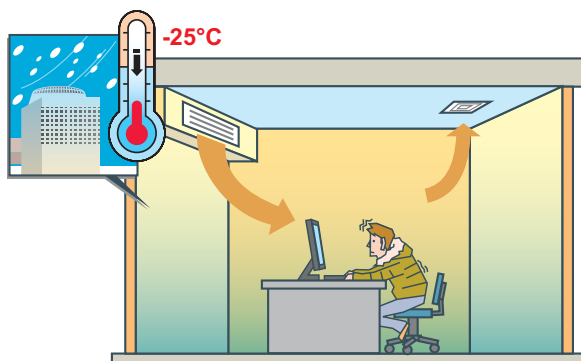

Previously, heating performance dropped off when the temperature fell below -20°C!

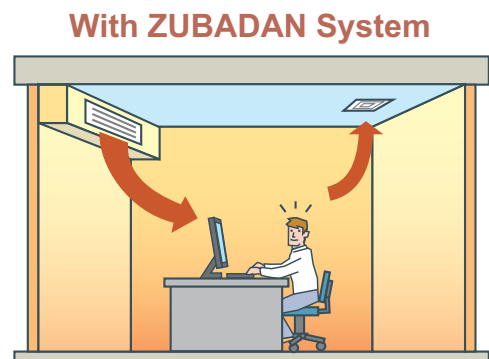

The new ZUBADAN System has no trouble keeping the occupants nice and warm at such temperatures.



High Static Pressure Setting

With our new ZUBADAN model, high static pressure setting up to 60Pa is available by setting the dip switch (0Pa at factory setting) making it an ideal and flexible solution for any type of application.

Shorter Warm-up in about 20 Min.

With its new improved startup performance, the ZUBADAN system achieves full heating capacity even when outdoor temperatures are as low as -15°C. Heating capacity, about 20 minutes after startup is improved by 40% compared to conventional models; ensuring occupants have an immediate comfortable air solution.

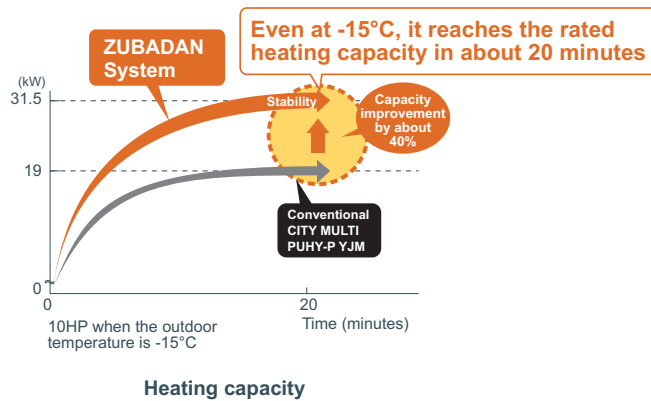

Reliable and Long Product Life Cycle

Backup Function (HP400 and HP500 models)

The ZUBADAN system ensures an exceptionally high level of reliability by utilising a new backup function, which can be easily operated in the event of a malfunction from an indoor unit remote controller.



Rotation Function (HP400 and HP500 models)

Running outdoor units alternately using its newly developed 'Rotation Function', the system is able to ensure an optimum product life cycle for both of its component units.



Outdoor Unit

Maximum Stable Operation

By utilising our advanced Flash Injection Circuit, the system can not only provide continuous heating for up to 250 minutes in one continuous cycle, but also significantly lessens defrost time to give exceptionally stable heating operation.

Heating up to 250 min. straight

Reduced Defrosting time

Startup Comfort

One of the key factors of the units' newly designed Flash Injection Circuit is that the optimal amount of refrigerant can be provided to the system via the compressor through a specially designed injection port to ensure particularly stable operation. In simple terms, the system allows a quick startup time and continuous heating; even in low ambient conditions.

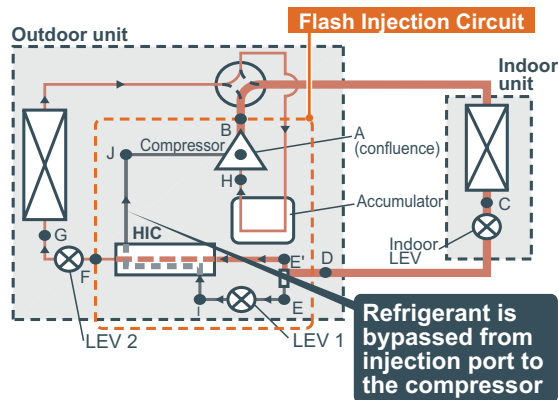

Note: Heat Interchange Circuit (HIC)
 Heating efficiency is improved by enhancing the recollection of heat at the outdoor unit with the low temperature refrigerant from the HIC.

Constant Comfort

With its new highly effective defrost feature (which prevents automatic defrosting when it is not required), the ZUBADAN System can deliver conditioned heating operation for up to 250 minutes in one continuous cycle!

Heating capacity is maintained by the Flash-injection circuit.

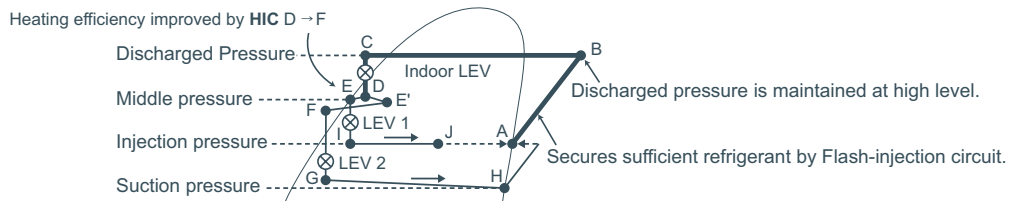

[Pressure Enthalpy diagram showing HIC]

Features of Y (Heat Pump) Series & R2 (Heat Recovery) Series

Compact Design Industry Leading Weight Saving

The manageability of the outdoor unit has been improved due to a drastic reduction in its weight, leading to easy transportation and installation.

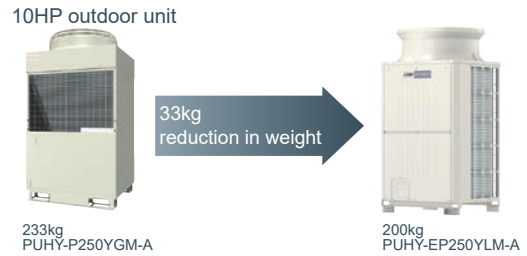

Industry Leading Space Saving

Reduced dimensions mean the outdoor unit can be transported through a 800mm wide door.

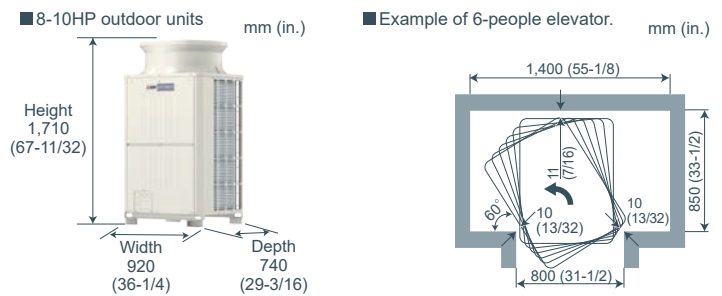

Effective Use of Space

The new models have a smaller foot print and service space requirements than previous models.

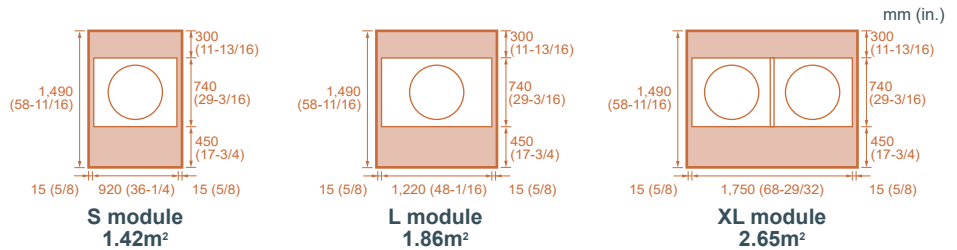

18HP (Yseries)

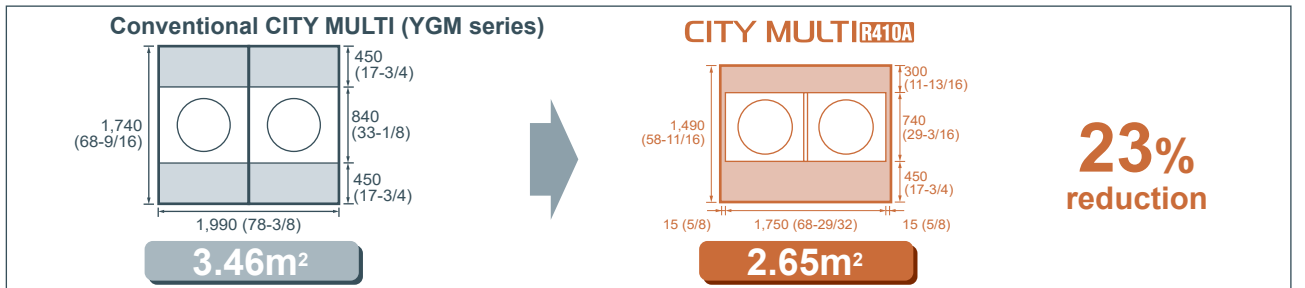

The unit can be transported easily within slender buildings.



The narrow space between buildings makes it difficult to use a crane.



Outdoor Unit

Low Noise Levels, New Fan Design

CITY MULTI VRF systems led the introduction of larger single fan motors some ten years ago, achieving substantially lower noise levels over multiple designs.

Continuing development in the design of blade shape and weight, Mitsubishi Electric have managed to achieve even higher performance and lower noise levels. To reduce noise levels further and comply with inner city residential noise regulations, all outdoor units include low noise mode. This function works by lowering the fan speed and compressor frequency proportionally with reduction in demand.

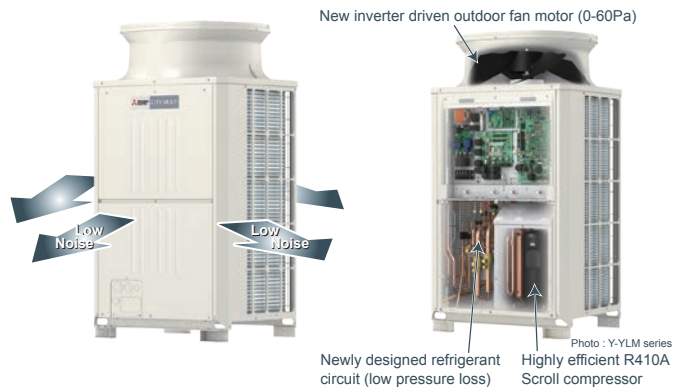

The compressor compartment is sealed by metal panels to attain low noise levels in all directions.

R410A Pipe Sizing

As R410A has a higher specific heat capacity than R22, the pipework is smaller. This means the pipe itself is cheaper, easier to install and less riser space is required within the building.

Conventional		CITY MULTI R410A	
Gas piping	Liquid piping	Gas piping	Liquid piping
ø28.58 (ø1-1/8)	ø12.7 (ø1/2)	ø22.2 (ø7/8)	ø9.52 (ø3/8)

mm (in.)

Based on 10HP model

Easy Maintenance

Even when one of the indoor units in the system is under maintenance, the other indoor unit can still operate.

* Not applicable to all situations.

* Be sure to turn off the power to the indoor unit when repairing or servicing the unit.

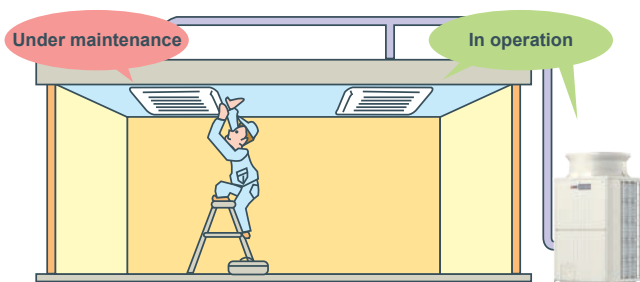

Blue Fin Treatment (PUHY-P-YKB/ PURY-P-YLM only)

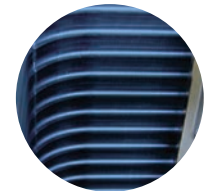

The anti-corrosion Blue Fin treatment of the heat exchanger is especially effective in urban environments where traffic pollution can damage the aluminum fins reducing the capacity and life expectancy of the unit. All CITY MULTI R410A outdoor units have been treated with Blue Fin.

*Standard: Anti-corrosion Blue Fin treatment & copper tube.
BS type (optional): salt-resistant cross fin & copper tube.

Salt Resistant Cross Fin (PUHY/PURY-EP-Y(S)LM-A only)

For PUHY/PURY-EP-Y(S)LM-A with aluminum flat-tube heat exchanger, salt resistant cross fin is provided as standard.

Refer to B.S. Specification sheet on p.167

60Pa High Static Pressure as Standard

Both Y and R2 series correspond to high static pressure of 60Pa, ideal and flexible for any type of application.

System Check

Ensuring simple and easy maintenance, system tests are available to check wiring, sensors and refrigerant volume.

Water Cooled Series



Heating or Cooling

WY series — PQHY-P Y(S)LM-A

WR2 series — PQRV-P Y(S)LM-A

[WY (Heat Pump) series]

Water energy source system allows switching between heating and cooling.

The WY-Series has all the benefits of the Y-Series using water source condensing units. Condensing units can be situated indoors allowing greater design flexibility and no limitation on building size. Depending on capacity, up to 15 to 50 indoor units can be connected to a single condensing unit with individualised and/or centralised control. The two-pipe system allows all CITY MULTI solutions to switch between heating and cooling while maintaining a constant indoor temperature.

Installation image (WY series)

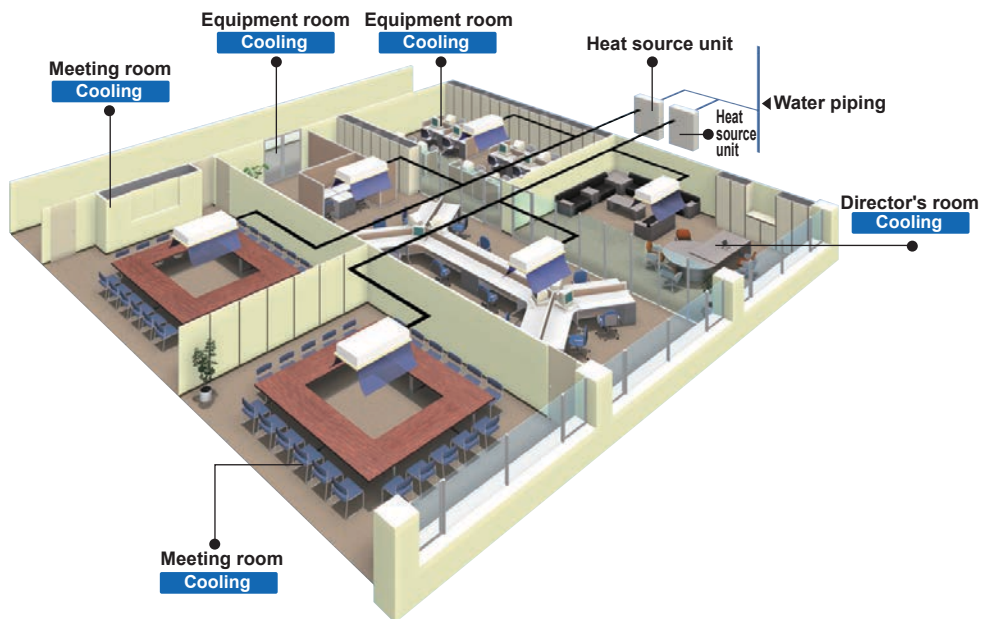

System Pipe Lengths

[P200-P900 (WY series)]

Refrigerant Piping Lengths		Maximum meters [Feet]
Total length	300-500 [984-1640]
Maximum allowable length	165 (190 equivalent) [541(623)]
Farthest indoor from first branch	40 [131]
Vertical differentials between units		Maximum meters [Feet]
Indoor/heat source (heat source higher)	50 [164]
Indoor/heat source (heat source lower)	40 [131]
Indoor/indoor	15 [49]

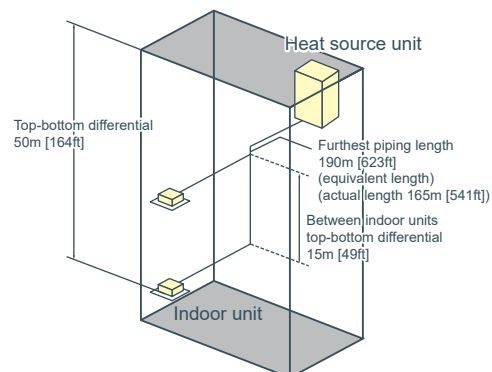

Outdoor Unit

[WR2 (Heat Recovery) series]

Advanced water heat source unit enjoying the benefits of R2 series

The CITY MULTI WR2 series provides all of the advantages of the R2 series with the added advantages of a water heat source system, making it suitable for a wider range of applications in high rises, frigid climates, coastal areas, etc.

Not only does it produce heat recovery from the indoor units on the same 2-pipe refrigerant circuit, it also produces heat recovery via the water circuit between heat source units, making it a very economical system.

Installation image (WR2 series)

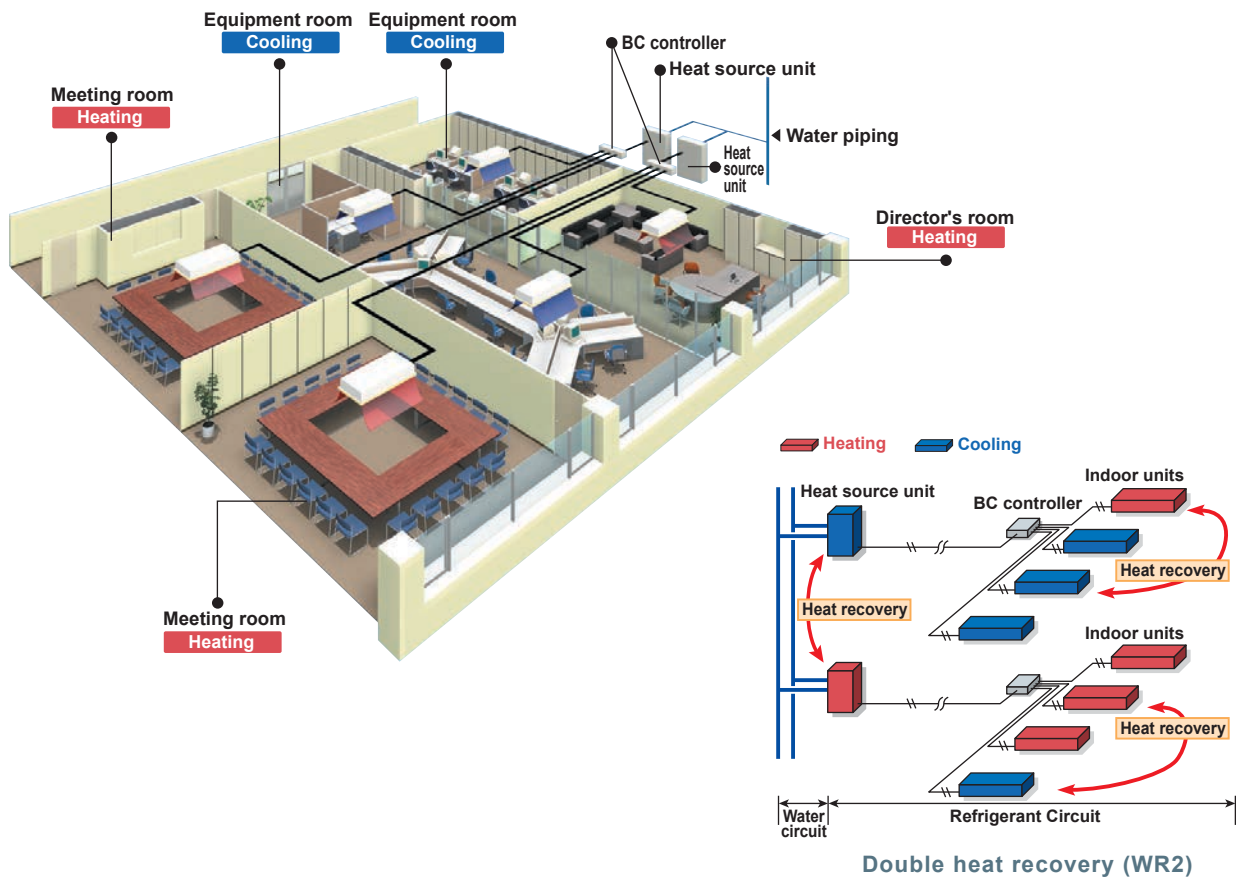

System Pipe Lengths

[P200-P900 (WR2 series)]

Refrigerant Piping Lengths		Maximum meters [Feet]
Total length	550-750 [1,804-2,460]
Maximum allowable length	165 (190 equivalent) [541 (623)]
Maximum length between heat source and single/main BC controller	110 [360]*1
*Maximum total length is dependent upon the distance between the outdoor unit and the single/main BC Controller.		
Maximum length between single/main BC controller and indoor	40 [131]*2
Vertical differentials between units		Maximum meters [Feet]
Indoor/ heat source (heat source higher)	50 [164]
Indoor/ heat source (heat source lower)	40 [131]
Indoor/BC controller (single/main)	15 (10) [49 (32)]*3
Indoor/indoor	30 (20) [98 (65)]*4
Main BC Controller/Sub BC Controller	15 (10) [49 (32)]*5

*1 Details refer to the DATA BOOK.
 *2 Farthest Indoor from BC controller can exceed 40m [131ft.] till 60m [197ft.] if no Indoor sized P200, P250 connected.
 Details refer to the DATA BOOK.
 *3 Distance of Indoor sized P200, P250 from BC must be less than 10m [32ft.] , if any.
 *4 Distance of Indoor sized P200, P250 from IU must be less than 20m [65ft.] , if any.
 *5 Distance between BC (Main) and BC (Sub) must be less than 10 m, if two BC (Sub) are installed or Indoor sized P200 and/or P250 is connected.

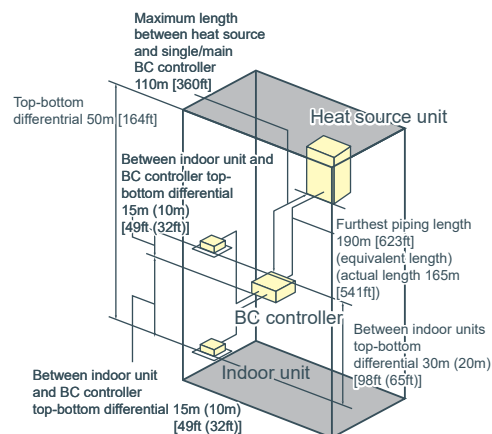

OUTDOOR UNIT

S Series

PUMY-P VKM-A(-BS)



► Specifications

Model	PUMY-P112VKM-A (-BS)		PUMY-P125VKM-A (-BS)		PUMY-P140VKM-A (-BS)		
Power source	1-phase 230V 50Hz		1-phase 230V 50Hz		1-phase 230V 50Hz		
Cooling capacity (Nominal)	*1 kW	12.5	14.0	15.5			
	*1 BTU / h	42,700	47,800	52,900			
	Power input kW	2.79	3.46	4.52			
	Current input A	12.32	15.27	19.95			
	AEER/EER kW / kW	4.13/4.48	3.76/4.05	3.22/3.43			
Temp. range of cooling	Indoor temp. W.B.	15.0~24.0°C(59~75°F)	15.0~24.0°C(59~75°F)	15.0~24.0°C(59~75°F)			
	Outdoor temp. D.B.	-5.0~46.0°C(23~115°F)	-5.0~46.0°C(23~115°F)	-5.0~46.0°C(23~115°F)			
Heating capacity (Nominal)	*2 kW	14.0	16.0	18.0			
	*2 BTU / h	47,800	54,600	61,400			
	Power input kW	3.13	3.74	4.47			
	Current input A	13.82	16.51	19.73			
	ACOP/COP kW / kW	4.20/4.47	4.03/4.28	3.81/4.03			
Temp. range of heating	Indoor temp. D.B.	15.0~27.0°C(59~81°F)	15.0~27.0°C(59~81°F)	15.0~27.0°C(59~81°F)			
	Outdoor temp. W.B.	-20.0°C(-4°F)	-20.0°C(-4°F)	-20.0°C(-4°F)			
Indoor unit connectable	Total capacity	50~130 % of outdoor unit capacity	50~130 % of outdoor unit capacity	50~130 % of outdoor unit capacity			
	Model / Quantity	P15~P140/9	P15~P140/10	P15~P140/12			
Sound pressure level (measured in anechoic room)	dB <A>	49/51	50/52	51/54			
Refrigerant piping diameter	Liquid pipe mm (in.)	9.52(3/8) Flare	9.52(3/8) Flare	9.52(3/8) Flare			
	Gas pipe mm (in.)	15.88(5/8) Flare	15.88(5/8) Flare	15.88(5/8) Flare			
FAN	Type x Quantity	Propeller Fan x 2		Propeller Fan x 2			
	Air flow rate	m³/min	110	120	120		
		L/s	1,833	1,833	2,000		
		cfm	3,884	3,884	4,237		
	Motor output kW	0.06 + 0.06	0.06 + 0.06	0.06 + 0.06			
Compressor	Type x Quantity	Scroll hermetic compressor x 1		Scroll hermetic compressor x 1			
	Starting method	Inverter		Inverter			
	Motor output kW	3.0	3.5	4.0			
External finish	Galvanized Steel Sheet Munsell No. 3Y 7.8/1.1		Galvanized Steel Sheet Munsell No. 3Y 7.8/1.1		Galvanized Steel Sheet Munsell No. 3Y 7.8/1.1		
External dimension HxWxD	mm	1,338 x 1,050 x 330 (+25)	1,338 x 1,050 x 330 (+25)	1,338 x 1,050 x 330 (+25)			
	in.	52-11/16 x 41-11/32 x 13 (+1)	52-11/16 x 41-11/32 x 13 (+1)	52-11/16 x 41-11/32 x 13 (+1)			
Protection devices	High pressure protection	High pressure Switch		High pressure Switch			
	Inverter circuit (COMP/FAN)	Overcurrent detection, Overheat detection (Heatsink thermistor)		Overcurrent detection, Overheat detection (Heatsink thermistor)			
	Compressor	Compressor thermistor, Over current detection		Compressor thermistor, Over current detection			
	Fan motor	Overheating, Voltage protection		Overheating, Voltage protection			
Refrigerant	Type x original charge	R410A 4.8kg		R410A 4.8kg			
Net weight	kg (lbs)	123(272)		123(272)			
Heat exchanger		Plate fin coil		Plate fin coil			
Defrosting method		Reversed refrigerant circuit		Reversed refrigerant circuit			
Optional parts		Joint: CMY-Y62-G-E Header: CMY-Y64/68-G-E		Joint: CMY-Y62-G-E Header: CMY-Y64/68-G-E			

Notes:

*1,*2 Nominal conditions

	Indoor	Outdoor	Pipe length	Level difference
Cooling	27°C DB/19°C WB (81°F DB/66°F WB)	35°C DB(95°F DB)	7.5m (24-9/16ft.)	0m (0ft.)
Heating	20°C DB(68°F DB)	7°C DB/6°C WB(45°F DB/43°F WB)	7.5m (24-9/16ft.)	0m (0ft.)

*Nominal condition *1,*2 are subject to ISO 15042.

*Due to continuing improvement, above specification may be subject to change without notice.



OUTDOOR UNIT

S Series

PUMY-P YKM-A(-BS)



► Specifications

Model	PUMY-P112YKM-A (-BS)		PUMY-P125YKM-A (-BS)		PUMY-P140YKM-A (-BS)		
Power source	3-phase 400V 50Hz		3-phase 400V 50Hz		3-phase 400V 50Hz		
Cooling capacity (Nominal)	*1 kW	12.5	14.0	15.5			
	*1 BTU / h	42,700	47,800	52,900			
	Power input kW	2.79	3.46	4.52			
	Current input A	4.24	5.26	6.87			
	AEER/EER kW / kW	4.07/4.48	3.71/4.05	3.19/3.43			
Temp. range of cooling	Indoor temp. W.B.	15.0~24.0°C(59~75°F)	15.0~24.0°C(59~75°F)	15.0~24.0°C(59~75°F)			
	Outdoor temp. D.B.	-5.0~46.0°C(23~115°F)	-5.0~46.0°C(23~115°F)	-5.0~46.0°C(23~115°F)			
Heating capacity (Nominal)	*2 kW	14.0	16.0	18.0			
	*2 BTU / h	47,800	54,600	61,400			
	Power input kW	3.13	3.74	4.47			
	Current input A	4.76	5.68	6.79			
	ACOP/COP kW / kW	4.14/4.47	3.99/4.28	3.78/4.03			
Temp. range of heating	Indoor temp. D.B.	15.0~27.0°C(59~81°F)	15.0~27.0°C(59~81°F)	15.0~27.0°C(59~81°F)			
	Outdoor temp. W.B.	-20.0°C(-4°F)	-20.0°C(-4°F)	-20.0°C(-4°F)			
Indoor unit connectable	Total capacity	50~130 % of outdoor unit capacity	50~130 % of outdoor unit capacity	50~130 % of outdoor unit capacity			
	Model / Quantity	P15~P140/9	P15~P140/10	P15~P140/12			
Sound pressure level (measured in anechoic room)	dB <A>	49/51	50/52	51/54			
Refrigerant piping diameter	Liquid pipe mm (in.)	9.52(3/8) Flare	9.52(3/8) Flare	9.52(3/8) Flare			
	Gas pipe mm (in.)	15.88(5/8) Flare	15.88(5/8) Flare	15.88(5/8) Flare			
FAN	Type x Quantity	Propeller Fan x 2		Propeller Fan x 2			
	Air flow rate	m³/min	110	120	120		
		L/s	1,833	1,833	2,000		
		cfm	3,884	3,884	4,237		
	Motor output kW	0.06 + 0.06	0.06 + 0.06	0.06 + 0.06			
Compressor	Type x Quantity	Scroll hermetic compressor x 1		Scroll hermetic compressor x 1			
	Starting method	Inverter		Inverter			
	Motor output kW	3.0	3.5	4.0			
External finish	Galvanized Steel Sheet Munsell No. 3Y 7.8/1.1		Galvanized Steel Sheet Munsell No. 3Y 7.8/1.1		Galvanized Steel Sheet Munsell No. 3Y 7.8/1.1		
External dimension HxWxD	mm	1,338 x 1,050 x 330 (+25)	1,338 x 1,050 x 330 (+25)	1,338 x 1,050 x 330 (+25)			
	in.	52-11/16 x 41-11/32 x 13 (+1)	52-11/16 x 41-11/32 x 13 (+1)	52-11/16 x 41-11/32 x 13 (+1)			
Protection devices	High pressure protection	High pressure Switch		High pressure Switch			
	Inverter circuit (COMP./FAN)	Overcurrent detection, Overheat detection (Heatsink thermistor)		Overcurrent detection, Overheat detection (Heatsink thermistor)			
	Compressor	Compressor thermistor, Over current detection		Compressor thermistor, Over current detection			
	Fan motor	Overheating, Voltage protection		Overheating, Voltage protection			
Refrigerant	Type x original charge	R410A 4.8kg		R410A 4.8kg			
Net weight	kg (lbs)	125(276)		125(276)			
Heat exchanger	Plate fin coil		Plate fin coil		Plate fin coil		
Defrosting method	Reversed refrigerant circuit		Reversed refrigerant circuit		Reversed refrigerant circuit		
Optional parts	Joint: CMY-Y62-G-E Header: CMY-Y64/68-G-E		Joint: CMY-Y62-G-E Header: CMY-Y64/68-G-E		Joint: CMY-Y62-G-E Header: CMY-Y64/68-G-E		

Notes:

*1,*2 Nominal conditions

	Indoor	Outdoor	Pipe length	Level difference
Cooling	27°C DB/19°C WB (81°F DB/66°F WB)	35°C DB(95°F DB)	7.5m (24-9/16ft.)	0m (0ft.)
Heating	20°C DB(68°F DB)	7°C DB/6°C WB(45°F DB/43°F WB)	7.5m (24-9/16ft.)	0m (0ft.)

*Nominal condition *1,*2 are subject to ISO 15042.

*Due to continuing improvement, above specification may be subject to change without notice.

OUTDOOR UNIT

Y Series

PUHY-P YKB-A(-BS)



► Specifications

Model		PUHY-P200YKB-A (-BS)	PUHY-P250YKB-A (-BS)	
Power source		3-phase 4-wire 380-400-415 V 50/60 Hz		
Cooling capacity (Nominal)	*1 kW	22.4	28.0	
	*1 BTU / h	76,400	95,500	
	Power input kW	6.12	8.09	
	Current input A	10.3-9.8-9.4	13.6-12.9-12.5	
	EER kW / kW	3.66	3.46	
Temp. range of cooling	Indoor W.B.	15.0~24.0°C (59~75°F)	15.0~24.0°C (59~75°F)	
	Outdoor D.B.	-5.0~52.0°C (23~126°F)	-5.0~52.0°C (23~126°F)	
Heating capacity (Nominal)	*2 kW	25.0	31.5	
	*2 BTU / h	85,300	107,500	
	Power input kW	6.15	8.33	
	Current input A	10.3-9.8-9.5	14.0-13.3-12.8	
	COP kW / kW	4.06	3.78	
Temp. range of heating	Indoor D.B.	15.0~27.0°C (59~81°F)	15.0~27.0°C (59~81°F)	
	Outdoor W.B.	-20.0~15.5°C (-4~60°F)	-20.0~15.5°C (-4~60°F)	
Indoor unit connectable	Total capacity	50~130% of outdoor unit capacity	50~130% of outdoor unit capacity	
	Model / Quantity	P15-P250/1~17	P15-P250/1~21	
Sound pressure level (measured in anechoic room)	dB <A>	57	59	
Sound power level (measured in anechoic room)	dB <A>	78	79	
Refrigerant piping diameter	Liquid pipe mm (in.)	9.52 (3/8) Brazed	9.52 (3/8) Brazed (12.7 (1/2) Brazed, farthest length >= 90 m)	
	Gas pipe mm (in.)	22.2 (7/8) Brazed	22.2 (7/8) Brazed	
FAN	Type x Quantity	Propeller fan x 1		
	Air flow rate	m ³ /min	175	
		L/s	2,917	
		cfm	6,179	
	Driving mechanism	Inverter-control, Direct-driven by motor		
	Motor output kW	0.92 x 1		
	*3 External static press.	0 Pa (0 mmH ₂ O)		
Compressor	Type x Quantity	Inverter scroll hermetic compressor		
	Starting method	Inverter		
	Motor output kW	5.5		
	Case heater kW	-		
External finish	Pre-coated galvanized steel sheets (+powder coating for -BS type) <MUNSELL 5Y 8/1 or similar>			
External dimension HxWxD	mm	1,710 (1,650 without legs) x 920 x 740		
	in.	67-3/8 (65 without legs) x 36-1/4 x 29-3/16		
Protection devices	High pressure protection	High pressure sensor, High pressure switch at 4.15 MPa (601 psi)		
	Inverter circuit (COMP./FAN)	Over-heat protection, Over-current protection		
	Compressor	Over-heat protection		
	Fan motor	Over-current protection		
Refrigerant	Type x original charge	R410A x 6.5 kg (15 lbs)		
Net weight	kg (lbs)	190 (419)		
Heat exchanger	Salt-resistant cross fin & copper tube			
Optional parts	Joint: CMY-Y102SS/LS-G2 Header: CMY-Y104/108/1010-G			

Notes:

*1,*2 Nominal conditions

	Indoor	Outdoor	Pipe length	Level difference
Cooling	27°C DB/19°C WB (81°F DB/66°F WB)	35°C DB/24°C WB (95°F DB/75°F WB)	7.5m (24-9/16ft.)	0m (0ft.)
Heating	20°C DB(68°F DB)	7°C DB/6°C WB(45°F DB/43°F WB)	7.5m (24-9/16ft.)	0m (0ft.)

*3 External static pressure option is available (30Pa, 60Pa / 3.1mmH₂O, 6.1mmH₂O).

*Nominal condition *1,*2 are subject to JIS B8615-1.

*Due to continuing improvement, above specification may be subject to change without notice.



OUTDOOR UNIT

Y Series

PUHY-P YKB-A(-BS)



► Specifications

Model		PUHY-P300YKB-A (-BS)	PUHY-P350YKB-A (-BS)	
Power source		3-phase 4-wire 380-400-415 V 50/60 Hz		
Cooling capacity (Nominal)	*1 kW	33.5	40.0	
	*1 BTU / h	114,300	136,500	
	Power input kW	9.49	11.79	
	Current input A	16.0-15.2-14.6	19.9-18.9-18.2	
	EER kW / kW	3.53	3.39	
Temp. range of cooling	Indoor W.B.	15.0~24.0°C (59~75°F)	15.0~24.0°C (59~75°F)	
	Outdoor D.B.	-5.0~52.0°C (23~126°F)	-5.0~52.0°C (23~126°F)	
Heating capacity (Nominal)	*2 kW	37.5	45.0	
	*2 BTU / h	128,000	153,500	
	Power input kW	9.89	13.23	
	Current input A	16.6-15.8-15.2	22.3-21.2-20.4	
	COP kW / kW	3.79	3.40	
Temp. range of heating	Indoor D.B.	15.0~27.0°C (59~81°F)	15.0~27.0°C (59~81°F)	
	Outdoor W.B.	-20.0~15.5°C (-4~60°F)	-20.0~15.5°C (-4~60°F)	
Indoor unit connectable	Total capacity	50~130% of outdoor unit capacity	50~130% of outdoor unit capacity	
	Model / Quantity	P15-P250/1~26	P15-P250/1~30	
Sound pressure level (measured in anechoic room)	dB <A>	61	61	
Sound power level (measured in anechoic room)	dB <A>	83	83	
Refrigerant piping diameter	Liquid pipe mm (in.)	9.52 (3/8) Brazed (12.7 (1/2) Brazed, farthest length >= 40 m)	12.7 (1/2) Brazed	
	Gas pipe mm (in.)	22.2 (7/8) Brazed	28.58 (1-1/8) Brazed	
FAN	Type x Quantity	Propeller fan x 1	Propeller fan x 1	
	Air flow rate	m ³ /min	210	210
		L/s	3,500	3,500
		cfm	7,415	7,415
	Driving mechanism	Inverter-control, Direct-driven by motor	Inverter-control, Direct-driven by motor	
	Motor output kW	0.92 x 1	0.92 x 1	
*3 External static press.	0 Pa (0 mmH ₂ O)	0 Pa (0 mmH ₂ O)		
Compressor	Type x Quantity	Inverter scroll hermetic compressor	Inverter scroll hermetic compressor	
	Starting method	Inverter	Inverter	
	Motor output kW	8.1	10.5	
	Case heater kW	-	-	
External finish	Pre-coated galvanized steel sheets (+powder coating for -BS type) <MUNSELL 5Y 8/1 or similar>		Pre-coated galvanized steel sheets (+powder coating for -BS type) <MUNSELL 5Y 8/1 or similar>	
External dimension HxWxD	mm	1,710 (1,650 without legs) x 1,220 x 740	1,710 (1,650 without legs) x 1,220 x 740	
	in.	67-3/8 (65 without legs) x 48-1/16 x 29-3/16	67-3/8 (65 without legs) x 48-1/16 x 29-3/16	
Protection devices	High pressure protection	High pressure sensor, High pressure switch at 4.15 MPa (601 psi)	High pressure sensor, High pressure switch at 4.15 MPa (601 psi)	
	Inverter circuit (COMP./FAN)	Over-heat protection, Over-current protection	Over-heat protection, Over-current protection	
	Compressor	Over-heat protection	Over-heat protection	
	Fan motor	Over-current protection	Over-current protection	
Refrigerant	Type x original charge	R410A x 11.5 kg (26 lbs)	R410A x 11.5 kg (26 lbs)	
Net weight	kg (lbs)	251 (554)	251 (554)	
Heat exchanger		Salt-resistant cross fin & aluminium tube	Salt-resistant cross fin & copper tube	
Optional parts		Joint: CMY-Y102SS/LS-G2 Header: CMY-Y104/108/1010-G	Joint: CMY-Y102SS/LS-G2, CMY-Y202S-G2 Header: CMY-Y104/108/1010-G	

Notes:

*1,*2 Nominal conditions

	Indoor	Outdoor	Pipe length	Level difference
Cooling	27°C DB/19°C WB (81°F DB/66°F WB)	35°C DB/24°C WB (95°F DB/75°F WB)	7.5m (24-9/16ft.)	0m (0ft.)
Heating	20°C DB(68°F DB)	7°C DB/6°C WB(45°F DB/43°F WB)	7.5m (24-9/16ft.)	0m (0ft.)

*3 External static pressure option is available (30Pa, 60Pa / 3.1mmH₂O, 6.1mmH₂O).

*Nominal condition *1,*2 are subject to JIS B8615-1.

*Due to continuing improvement, above specification may be subject to change without notice.

OUTDOOR UNIT

Y Series

PUHY-P YSKB-A(-BS)



► Specifications

Model	PUHY-P400YSKB-A (-BS)		PUHY-P450YSKB-A (-BS)		PUHY-P500YSKB-A (-BS)		
Power source	3-phase 4-wire 380-400-415 V 50/60 Hz		3-phase 4-wire 380-400-415 V 50/60 Hz		3-phase 4-wire 380-400-415 V 50/60 Hz		
Cooling capacity (Nominal)	*1 kW	45.0	50.0	56.0	56.0	56.0	
	*1 BTU / h	153,500	170,600	191,100	191,100	191,100	
	Power input kW	12.96	14.74	16.91	16.91	16.91	
	Current input A	21.8-20.7-20.0	24.8-23.6-22.7	28.5-27.1-26.1	28.5-27.1-26.1	28.5-27.1-26.1	
EER	kW / kW	3.47	3.39	3.31	3.31	3.31	
	W.B.	15.0~24.0°C (59~75°F)	15.0~24.0°C (59~75°F)	15.0~24.0°C (59~75°F)	15.0~24.0°C (59~75°F)	15.0~24.0°C (59~75°F)	
Temp. range of cooling	D.B.	-5.0~52.0°C (23~126°F)	-5.0~52.0°C (23~126°F)	-5.0~52.0°C (23~126°F)	-5.0~52.0°C (23~126°F)	-5.0~52.0°C (23~126°F)	
	W.B.	-5.0~52.0°C (23~126°F)	-5.0~52.0°C (23~126°F)	-5.0~52.0°C (23~126°F)	-5.0~52.0°C (23~126°F)	-5.0~52.0°C (23~126°F)	
Heating capacity (Nominal)	*2 kW	50.0	56.0	63.0	63.0	63.0	
	*2 BTU / h	170,600	191,100	215,000	215,000	215,000	
	Power input kW	12.98	15.05	17.54	17.54	17.54	
	Current input A	21.9-20.8-20.0	25.4-24.1-23.2	29.6-28.1-27.1	29.6-28.1-27.1	29.6-28.1-27.1	
COP	kW / kW	3.85	3.72	3.59	3.59	3.59	
	D.B.	15.0~27.0°C (59~81°F)	15.0~27.0°C (59~81°F)	15.0~27.0°C (59~81°F)	15.0~27.0°C (59~81°F)	15.0~27.0°C (59~81°F)	
Temp. range of heating	W.B.	-20.0~15.5°C (-4~60°F)	-20.0~15.5°C (-4~60°F)	-20.0~15.5°C (-4~60°F)	-20.0~15.5°C (-4~60°F)	-20.0~15.5°C (-4~60°F)	
	D.B.	-20.0~15.5°C (-4~60°F)	-20.0~15.5°C (-4~60°F)	-20.0~15.5°C (-4~60°F)	-20.0~15.5°C (-4~60°F)	-20.0~15.5°C (-4~60°F)	
Indoor unit connectable	Total capacity	50~130% of outdoor unit capacity	50~130% of outdoor unit capacity	50~130% of outdoor unit capacity	50~130% of outdoor unit capacity	50~130% of outdoor unit capacity	
	Model / Quantity	P15-P250/1~34	P15-P250/1~39	P15-P250/1~43	P15-P250/1~43	P15-P250/1~43	
Sound pressure level (measured in anechoic room)	dB <A>	60	61.5	62	62	62	
Sound power level (measured in anechoic room)	dB <A>	81	82	82	82	82	
Refrigerant piping diameter	Liquid pipe mm (in.)	12.7 (1/2) Brazed	15.88 (5/8) Brazed	15.88 (5/8) Brazed	15.88 (5/8) Brazed	15.88 (5/8) Brazed	
	Gas pipe mm (in.)	28.58 (1-1/8) Brazed	28.58 (1-1/8) Brazed	28.58 (1-1/8) Brazed	28.58 (1-1/8) Brazed	28.58 (1-1/8) Brazed	
Set Model							
Model	PUHY-P200YKB-A (-BS)		PUHY-P250YKB-A (-BS)		PUHY-P250YKB-A (-BS)		
FAN	Type x Quantity	Propeller fan x 1	Propeller fan x 1	Propeller fan x 1	Propeller fan x 1	Propeller fan x 1	
	Air flow rate	m ³ /min	175	175	175	175	175
		L/s	2,917	2,917	2,917	2,917	2,917
		cfm	6,179	6,179	6,179	6,179	6,179
Driving mechanism	Inverter-control, Direct-driven by motor		Inverter-control, Direct-driven by motor		Inverter-control, Direct-driven by motor		
Motor output	kW	0.92 x 1	0.92 x 1	0.92 x 1	0.92 x 1	0.92 x 1	
	External static press.	0 Pa (0 mmH ₂ O)	0 Pa (0 mmH ₂ O)	0 Pa (0 mmH ₂ O)	0 Pa (0 mmH ₂ O)	0 Pa (0 mmH ₂ O)	
Compressor	Type x Quantity	Inverter scroll hermetic compressor		Inverter scroll hermetic compressor		Inverter scroll hermetic compressor	
	Starting method	Inverter	Inverter	Inverter	Inverter	Inverter	
	Motor output kW	5.5	5.5	5.5	6.9	6.9	
	Case heater kW	-	-	-	-	-	
External finish	Pre-coated galvanized steel sheets (+powder coating for -BS type) <MUNSELL 5Y 8/1 or similar>		Pre-coated galvanized steel sheets (+powder coating for -BS type) <MUNSELL 5Y 8/1 or similar>		Pre-coated galvanized steel sheets (+powder coating for -BS type) <MUNSELL 5Y 8/1 or similar>		
External dimension HxWxD	mm	1,710 (1,650 without legs) x 920 x 740	1,710 (1,650 without legs) x 920 x 740	1,710 (1,650 without legs) x 920 x 740	1,710 (1,650 without legs) x 920 x 740	1,710 (1,650 without legs) x 920 x 740	
	in.	67-3/8 (65 without legs) x 36-1/4 x 29-3/16	67-3/8 (65 without legs) x 36-1/4 x 29-3/16	67-3/8 (65 without legs) x 36-1/4 x 29-3/16	67-3/8 (65 without legs) x 36-1/4 x 29-3/16	67-3/8 (65 without legs) x 36-1/4 x 29-3/16	
Protection devices	High pressure protection	High pressure sensor, High pressure switch at 4.15 MPa (601 psi)		High pressure sensor, High pressure switch at 4.15 MPa (601 psi)		High pressure sensor, High pressure switch at 4.15 MPa (601 psi)	
	Inverter circuit (COMP./FAN)	Over-heat protection, Over-current protection		Over-heat protection, Over-current protection		Over-heat protection, Over-current protection	
	Compressor	Over-heat protection		Over-heat protection		Over-heat protection	
	Fan motor	Over-current protection		Over-current protection		Over-current protection	
Refrigerant	Type x original charge	R410A x 6.5 kg (15 lbs)	R410A x 6.5 kg (15 lbs)	R410A x 6.5 kg (15 lbs)	R410A x 8.0 kg (18 lbs)	R410A x 8.0 kg (18 lbs)	
Net weight	kg (lbs)	190 (419)	190 (419)	190 (419)	199 (439)	199 (439)	
Heat exchanger	Salt-resistant cross fin & copper tube		Salt-resistant cross fin & copper tube		Salt-resistant cross fin & copper tube		
Pipe between unit and distributor	Liquid pipe mm (in.)	9.52 (3/8) Brazed	9.52 (3/8) Brazed	9.52 (3/8) Brazed	9.52 (3/8) Brazed	9.52 (3/8) Brazed	
	Gas pipe mm (in.)	22.2 (7/8) Brazed	22.2 (7/8) Brazed	22.2 (7/8) Brazed	22.2 (7/8) Brazed	22.2 (7/8) Brazed	
Optional parts	Outdoor Twinning kit: CMY-Y100VBK3 Joint: CMY-Y102SS/LS-G2, CMY-Y202S/302S-G2 Header: CMY-Y104/108/1010-G		Outdoor Twinning kit: CMY-Y100VBK3 Joint: CMY-Y102SS/LS-G2, CMY-Y202S/302S-G2 Header: CMY-Y104/108/1010-G		Outdoor Twinning kit: CMY-Y100VBK3 Joint: CMY-Y102SS/LS-G2, CMY-Y202S/302S-G2 Header: CMY-Y104/108/1010-G		

Notes:

*1,*2 Nominal conditions

	Indoor	Outdoor	Pipe length	Level difference
Cooling	27°C DB/19°C WB (81°F DB/66°F WB)	35°C DB/24°C WB (95°F DB/75°F WB)	7.5m (24-9/16ft.)	0m (0ft.)
Heating	20°C DB(68°F DB)	7°C DB/6°C WB(45°F DB/43°F WB)	7.5m (24-9/16ft.)	0m (0ft.)

*3 External static pressure option is available (30Pa, 60Pa / 3.1mmH₂O, 6.1mmH₂O).

*Nominal condition *1,*2 are subject to JIS B8615-1.

*Due to continuing improvement, above specification may be subject to change without notice.

OUTDOOR UNIT

Y Series

PUHY-P YSKB-A(-BS)



► Specifications

Model	PUHY-P550YSKB-A (-BS)		PUHY-P600YSKB-A (-BS)		PUHY-P650YSKB-A (-BS)		
Power source	3-phase 4-wire 380-400-415 V 50/60 Hz		3-phase 4-wire 380-400-415 V 50/60 Hz		3-phase 4-wire 380-400-415 V 50/60 Hz		
Cooling capacity (Nominal)	*1 kW	63.0	69.0	73.0			
	*1 BTU / h	215,000	235,400	249,100			
	Power input kW	18.91	21.16	22.25			
	Current input A	31.9-30.3-29.2	35.7-33.9-32.7	37.5-35.6-34.3			
	EER kW / kW	3.33	3.26	3.28			
Temp. range of cooling	Indoor W.B.	15.0~24.0°C (59~75°F)	15.0~24.0°C (59~75°F)	15.0~24.0°C (59~75°F)			
	Outdoor D.B.	-5.0~52.0°C (23~126°F)	-5.0~52.0°C (23~126°F)	-5.0~52.0°C (23~126°F)			
Heating capacity (Nominal)	*2 kW	69.0	76.5	81.5			
	*2 BTU / h	235,400	261,000	278,100			
	Power input kW	19.22	22.43	23.90			
	Current input A	32.4-30.8-29.7	37.8-35.9-34.6	40.3-38.3-36.9			
	COP kW / kW	3.59	3.41	3.41			
Temp. range of heating	Indoor D.B.	15.0~27.0°C (59~81°F)	15.0~27.0°C (59~81°F)	15.0~27.0°C (59~81°F)			
	Outdoor W.B.	-20.0~15.5°C (-4~60°F)	-20.0~15.5°C (-4~60°F)	-20.0~15.5°C (-4~60°F)			
Indoor unit connectable	Total capacity	50~130% of outdoor unit capacity		50~130% of outdoor unit capacity			
	Model / Quantity	P15-P250/2~47		P15-P250/2~50			
Sound pressure level (measured in anechoic room)	dB <A>	63.5	63.5	64			
Sound power level (measured in anechoic room)	dB <A>	84.5	84.5	86			
Refrigerant piping diameter	Liquid pipe mm (in.)	15.88 (5/8) Brazed	15.88 (5/8) Brazed	15.88 (5/8) Brazed			
	Gas pipe mm (in.)	28.58 (1-1/8) Brazed	28.58 (1-1/8) Brazed	28.58 (1-1/8) Brazed			
Set Model							
Model	PUHY-P250YKB-A (-BS)	PUHY-P300YKB-A (-BS)	PUHY-P250YKB-A (-BS)	PUHY-P350YKB-A (-BS)	PUHY-P300YKB-A (-BS)	PUHY-P350YKB-A (-BS)	
FAN	Type x Quantity	Propeller fan x 1	Propeller fan x 1	Propeller fan x 1	Propeller fan x 1	Propeller fan x 1	
	Air flow rate	m ³ /min	175	210	175	210	210
		L/s	2,917	3,500	2,917	3,500	3,500
		cfm	6,179	7,415	6,179	7,415	7,415
	Driving mechanism	Inverter-control, Direct-driven by motor		Inverter-control, Direct-driven by motor		Inverter-control, Direct-driven by motor	
*3 Motor output	kW	0.92 x 1	0.92 x 1	0.92 x 1	0.92 x 1	0.92 x 1	
	External static press.	0 Pa (0 mmH ₂ O)	0 Pa (0 mmH ₂ O)	0 Pa (0 mmH ₂ O)	0 Pa (0 mmH ₂ O)	0 Pa (0 mmH ₂ O)	
Compressor	Type x Quantity	Inverter scroll hermetic compressor		Inverter scroll hermetic compressor		Inverter scroll hermetic compressor	
	Starting method	Inverter	Inverter	Inverter	Inverter	Inverter	
	Motor output kW	6.9	8.1	6.9	10.5	8.1	10.5
	Case heater kW	-	-	-	-	-	-
External finish	Pre-coated galvanized steel sheets (+powder coating for -BS type) <MUNSELL 5Y 8/1 or similar>		Pre-coated galvanized steel sheets (+powder coating for -BS type) <MUNSELL 5Y 8/1 or similar>		Pre-coated galvanized steel sheets (+powder coating for -BS type) <MUNSELL 5Y 8/1 or similar>		
External dimension HxWxD	mm	1,710 (1,650 without legs) x 920 x 740	1,710 (1,650 without legs) x 1,220 x 740	1,710 (1,650 without legs) x 920 x 740	1,710 (1,650 without legs) x 1,220 x 740	1,710 (1,650 without legs) x 1,220 x 740	
	in.	67-3/8 (65 without legs) x 36-1/4 x 29-3/16	67-3/8 (65 without legs) x 48-1/16 x 29-3/16	67-3/8 (65 without legs) x 36-1/4 x 29-3/16	67-3/8 (65 without legs) x 48-1/16 x 29-3/16	67-3/8 (65 without legs) x 48-1/16 x 29-3/16	
Protection devices	High pressure protection	High pressure sensor, High pressure switch at 4.15 MPa (601 psi)		High pressure sensor, High pressure switch at 4.15 MPa (601 psi)		High pressure sensor, High pressure switch at 4.15 MPa (601 psi)	
	Inverter circuit (COMP./FAN)	Over-heat protection, Over-current protection		Over-heat protection, Over-current protection		Over-heat protection, Over-current protection	
	Compressor	Over-heat protection		Over-heat protection		Over-heat protection	
	Fan motor	Over-current protection		Over-current protection		Over-current protection	
Refrigerant	Type x original charge	R410A x 8.0 kg (18 lbs)	R410A x 11.5 kg (26 lbs)	R410A x 8.0 kg (18 lbs)	R410A x 11.5 kg (26 lbs)	R410A x 11.5 kg (26 lbs)	
Net weight	kg (lbs)	199 (439)	251 (554)	199 (439)	251 (554)	251 (554)	
Heat exchanger	Salt-resistant cross fin & copper tube		Salt-resistant cross fin & copper tube		Salt-resistant cross fin & copper tube		
Pipe between unit and distributor	Liquid pipe mm (in.)	9.52 (3/8) Brazed	12.7 (1/2) Brazed	9.52 (3/8) Brazed	12.7 (1/2) Brazed	12.7 (1/2) Brazed	
	Gas pipe mm (in.)	22.2 (7/8) Brazed	22.2 (7/8) Brazed	22.2 (7/8) Brazed	28.58 (1-1/8) Brazed	22.2 (7/8) Brazed	
Optional parts	Outdoor Twinning kit: CMY-Y100VBK3 Joint: CMY-Y102SS/LS-G2, CMY-Y202S/302S-G2 Header: CMY-Y104/108/1010-G		Outdoor Twinning kit: CMY-Y100VBK3 Joint: CMY-Y102SS/LS-G2, CMY-Y202S/302S-G2 Header: CMY-Y104/108/1010-G		Outdoor Twinning kit: CMY-Y100VBK3 Joint: CMY-Y102SS/LS-G2, CMY-Y202S/302S-G2 Header: CMY-Y104/108/1010-G		

Notes:

*1,*2 Nominal conditions

	Indoor	Outdoor	Pipe length	Level difference
Cooling	27°C DB/19°C WB (81°F DB/66°F WB)	35°C DB/24°C WB (95°F DB/75°F WB)	7.5m (24-9/16ft.)	0m (0ft.)
Heating	20°C DB(68°F DB)	7°C DB/6°C WB(45°F DB/43°F WB)	7.5m (24-9/16ft.)	0m (0ft.)

*3 External static pressure option is available (30Pa, 60Pa / 3.1mmH₂O, 6.1mmH₂O).

*Nominal condition *1,*2 are subject to JIS B8615-1.

*Due to continuing improvement, above specification may be subject to change without notice.

OUTDOOR UNIT

Y Series

PUHY-P YSKB-A(-BS)



► Specifications

Model		PUHY-P700YSKB-A (-BS)		PUHY-P750YSKB-A (-BS)		PUHY-P800YSKB-A (-BS)		
Power source		3-phase 4-wire 380-400-415 V 50/60 Hz		3-phase 4-wire 380-400-415 V 50/60 Hz		3-phase 4-wire 380-400-415 V 50/60 Hz		
Cooling capacity (Nominal)	*1 kW	80.0		85.0		90.0		
	*1 BTU / h	273,000		290,000		307,100		
	Power input kW	24.84		27.68		29.50		
	Current input A	41.9-39.8-38.3		46.7-44.3-42.7		49.8-47.3-45.6		
EER	kW / kW	3.22		3.07		3.05		
	W.B.	15.0~24.0°C (59~75°F)		15.0~24.0°C (59~75°F)		15.0~24.0°C (59~75°F)		
Temp. range of cooling	D.B.	-5.0~52.0°C (23~126°F)		-5.0~52.0°C (23~126°F)		-5.0~52.0°C (23~126°F)		
	W.B.	-5.0~52.0°C (23~126°F)		-5.0~52.0°C (23~126°F)		-5.0~52.0°C (23~126°F)		
Heating capacity (Nominal)	*2 kW	88.0		95.0		100.0		
	*2 BTU / h	300,300		324,100		341,200		
	Power input kW	27.24		29.68		31.54		
	Current input A	45.9-43.6-42.1		50.1-47.5-45.8		53.2-50.5-48.7		
COP	kW / kW	3.23		3.20		3.17		
	D.B.	15.0~27.0°C (59~81°F)		15.0~27.0°C (59~81°F)		15.0~27.0°C (59~81°F)		
Temp. range of heating	W.B.	-20.0~15.5°C (-4~60°F)		-20.0~15.5°C (-4~60°F)		-20.0~15.5°C (-4~60°F)		
	W.B.	-20.0~15.5°C (-4~60°F)		-20.0~15.5°C (-4~60°F)		-20.0~15.5°C (-4~60°F)		
Indoor unit connectable	Total capacity	50~130% of outdoor unit capacity		50~130% of outdoor unit capacity		50~130% of outdoor unit capacity		
	Model / Quantity	P15-P250/2~50		P15-P250/2~50		P15-P250/2~50		
Sound pressure level (measured in anechoic room)	dB <A>	64		65.5		67.5		
Sound power level (measured in anechoic room)	dB <A>	86		86		87.5		
Refrigerant piping diameter	Liquid pipe mm (in.)	19.05 (3/4) Brazed		19.05 (3/4) Brazed		19.05 (3/4) Brazed		
	Gas pipe mm (in.)	34.93 (1-3/8) Brazed		34.93 (1-3/8) Brazed		34.93 (1-3/8) Brazed		
Set Model								
Model		PUHY-P350YKB-A (-BS)		PUHY-P350YKB-A (-BS)		PUHY-P400YKB-A (-BS)		
FAN	Type x Quantity	Propeller fan x 1		Propeller fan x 1		Propeller fan x 2		
	Air flow rate	m ³ /min	210		210		360	
		L/s	3,500		3,500		6,000	
		cfm	7,415		7,415		12,712	
Driving mechanism		Inverter-control, Direct-driven by motor		Inverter-control, Direct-driven by motor		Inverter-control, Direct-driven by motor		
	Motor output kW	0.92 x 1		0.92 x 1		0.92 x 1		
	External static press.	0 Pa (0 mmH ₂ O)		0 Pa (0 mmH ₂ O)		0 Pa (0 mmH ₂ O)		
Compressor	Type x Quantity	Inverter scroll hermetic compressor		Inverter scroll hermetic compressor		Inverter scroll hermetic compressor		
	Starting method	Inverter		Inverter		Inverter		
	Motor output kW	10.5		10.5		12.4		
	Case heater kW	-		-		0.045		
External finish		Pre-coated galvanized steel sheets (+powder coating for -BS type) <MUNSELL 5Y 8/1 or similar>		Pre-coated galvanized steel sheets (+powder coating for -BS type) <MUNSELL 5Y 8/1 or similar>		Pre-coated galvanized steel sheets (+powder coating for -BS type) <MUNSELL 5Y 8/1 or similar>		
External dimension HxWxD	mm	1,710 (1,650 without legs) x 1,220 x 740		1,710 (1,650 without legs) x 1,220 x 740		1,710 (1,650 without legs) x 1,750 x 740		
	in.	67-3/8 (65 without legs) x 48-1/16 x 29-3/16		67-3/8 (65 without legs) x 48-1/16 x 29-3/16		67-3/8 (65 without legs) x 68-15/16 x 29-3/16		
Protection devices	High pressure protection	High pressure sensor, High pressure switch at 4.15 MPa (601 psi)		High pressure sensor, High pressure switch at 4.15 MPa (601 psi)		High pressure sensor, High pressure switch at 4.15 MPa (601 psi)		
	Inverter circuit (COMP./FAN)	Over-heat protection, Over-current protection		Over-heat protection, Over-current protection		Over-heat protection, Over-current protection		
	Compressor	Over-heat protection, Over-current protection		Over-heat protection, Over-current protection		Over-heat protection, Over-current protection		
	Fan motor	Over-current protection		Over-current protection		Over-current protection		
Refrigerant	Type x original charge	R410A x 11.5 kg (26 lbs)		R410A x 11.5 kg (26 lbs)		R410A x 11.8 kg (27 lbs)		
Net weight	kg (lbs)	251 (554)		251 (554)		304 (671)		
Heat exchanger		Salt-resistant cross fin & copper tube		Salt-resistant cross fin & copper tube		Salt-resistant cross fin & copper tube		
Pipe between unit and distributor	Liquid pipe mm (in.)	12.7 (1/2) Brazed		12.7 (1/2) Brazed		12.7 (1/2) Brazed		
	Gas pipe mm (in.)	28.58 (1-1/8) Brazed		28.58 (1-1/8) Brazed		28.58 (1-1/8) Brazed		
Optional parts		Outdoor Twinning kit: CMY-Y200VBK2 Joint: CMY-Y102SS/LS-G2, CMY-Y202S/302S-G2 Header: CMY-Y104/108/1010-G		Outdoor Twinning kit: CMY-Y200VBK2 Joint: CMY-Y102SS/LS-G2, CMY-Y202S/302S-G2 Header: CMY-Y104/108/1010-G		Outdoor Twinning kit: CMY-Y200VBK2 Joint: CMY-Y102SS/LS-G2, CMY-Y202S/302S-G2 Header: CMY-Y104/108/1010-G		

Notes:

*1,*2 Nominal conditions

	Indoor	Outdoor	Pipe length	Level difference
Cooling	27°C DB/19°C WB (81°F DB/66°F WB)	35°C DB/24°C WB (95°F DB/75°F WB)	7.5m (24-9/16ft.)	0m (0ft.)
Heating	20°C DB(68°F DB)	7°C DB/6°C WB(45°F DB/43°F WB)	7.5m (24-9/16ft.)	0m (0ft.)

*3 External static pressure option is available (30Pa, 60Pa / 3.1mmH₂O, 6.1mmH₂O).

*Nominal condition *1,*2 are subject to JIS B8615-1.

*Due to continuing improvement, above specification may be subject to change without notice.

OUTDOOR UNIT

Y Series

PUHY-P YSKB-A(-BS)



► Specifications

Model		PUHY-P850YSKB-A (-BS)		PUHY-P900YSKB-A (-BS)						
Power source		3-phase 4-wire 380-400-415 V 50/60 Hz		3-phase 4-wire 380-400-415 V 50/60 Hz						
Cooling capacity (Nominal)	*1 kW	96.0		101.0						
	*1 BTU / h	327,600		344,600						
	Power input kW	33.10		35.06						
	Current input A	55.8-53.0-51.1		59.1-56.2-54.1						
EER	kW / kW	2.90		2.88						
Temp. range of cooling	Indoor W.B.	15.0~24.0°C (59~75°F)		15.0~24.0°C (59~75°F)						
	Outdoor D.B.	-5.0~52.0°C (23~126°F)		-5.0~52.0°C (23~126°F)						
Heating capacity (Nominal)	*2 kW	108.0		113.0						
	*2 BTU / h	368,500		385,600						
	Power input kW	34.28		36.21						
	Current input A	57.8-54.9-52.9		61.1-58.0-55.9						
COP	kW / kW	3.15		3.12						
Temp. range of heating	Indoor D.B.	15.0~27.0°C (59~81°F)		15.0~27.0°C (59~81°F)						
	Outdoor W.B.	-20.0~15.5°C (-4~60°F)		-20.0~15.5°C (-4~60°F)						
Indoor unit connectable	Total capacity	50~130% of outdoor unit capacity		50~130% of outdoor unit capacity						
	Model / Quantity	P15-P250/2~50		P15-P250/2~50						
Sound pressure level (measured in anechoic room)	dB <A>	68		69						
Sound power level (measured in anechoic room)	dB <A>	87.5		88						
Refrigerant piping diameter	Liquid pipe mm (in.)	19.05 (3/4) Brazed		19.05 (3/4) Brazed						
	Gas pipe mm (in.)	41.28 (1-5/8) Brazed		41.28 (1-5/8) Brazed						
Set Model										
Model		PUHY-P400YKB-A (-BS)		PUHY-P450YKB-A (-BS)		PUHY-P450YKB-A (-BS)		PUHY-P450YKB-A (-BS)		
FAN	Type x Quantity	Propeller fan x 1		Propeller fan x 2		Propeller fan x 2		Propeller fan x 2		
	Air flow rate	m ³ /min	210		360		360		360	
		L/s	3,500		6,000		6,000		6,000	
		cfm	7,415		12,712		12,712		12,712	
	Driving mechanism	Inverter-control, Direct-driven by motor				Inverter-control, Direct-driven by motor				
	Motor output	kW	0.92 x 1		0.92 x 2		0.92 x 2		0.92 x 2	
*3 External static press.		0 Pa (0 mmH ₂ O)		0 Pa (0 mmH ₂ O)		0 Pa (0 mmH ₂ O)		0 Pa (0 mmH ₂ O)		
Compressor	Type x Quantity	Inverter scroll hermetic compressor				Inverter scroll hermetic compressor				
	Starting method	Inverter		Inverter		Inverter		Inverter		
	Motor output	kW	10.8		12.4		12.4		12.4	
	Case heater	kW	-		0.045		0.045		0.045	
External finish		Pre-coated galvanized steel sheets (+powder coating for -BS type) <MUNSELL 5Y 8/1 or similar>				Pre-coated galvanized steel sheets (+powder coating for -BS type) <MUNSELL 5Y 8/1 or similar>				
External dimension HxWxD	mm	1,710 (1,650 without legs) x 1,220 x 740		1,710 (1,650 without legs) x 1,750 x 740		1,710 (1,650 without legs) x 1,750 x 740		1,710 (1,650 without legs) x 1,750 x 740		
		67-3/8 (65 without legs) x 48-1/16 x 29-3/16		67-3/8 (65 without legs) x 68-15/16 x 29-3/16		67-3/8 (65 without legs) x 68-15/16 x 29-3/16		67-3/8 (65 without legs) x 68-15/16 x 29-3/16		
Protection devices	High pressure protection	High pressure sensor, High pressure switch at 4.15 MPa (601 psi)				High pressure sensor, High pressure switch at 4.15 MPa (601 psi)				
	Inverter circuit (COMP./FAN)	Over-heat protection, Over-current protection				Over-heat protection, Over-current protection				
	Compressor	Over-heat protection		Over-heat protection		Over-heat protection		Over-heat protection		
	Fan motor	Over-current protection		Over-current protection		Over-current protection		Over-current protection		
Refrigerant	Type x original charge	R410A x 11.5 kg (26 lbs)		R410A x 11.8 kg (27 lbs)		R410A x 11.8 kg (27 lbs)		R410A x 11.8 kg (27 lbs)		
Net weight	kg (lbs)	251 (554)		304 (671)		304 (671)		304 (671)		
Heat exchanger		Salt-resistant cross fin & copper tube				Salt-resistant cross fin & copper tube				
Pipe between unit and distributor	Liquid pipe mm (in.)	15.88 (5/8) Brazed		15.88 (5/8) Brazed		15.88 (5/8) Brazed		15.88 (5/8) Brazed		
	Gas pipe mm (in.)	28.58 (1-1/8) Brazed		28.58 (1-1/8) Brazed		28.58 (1-1/8) Brazed		28.58 (1-1/8) Brazed		
Optional parts		Outdoor Twinning kit: CMY-Y200VBK2 Joint: CMY-Y102SS/LS-G2, CMY-Y202S/302S-G2 Header: CMY-Y104/108/1010-G				Outdoor Twinning kit: CMY-Y200VBK2 Joint: CMY-Y102SS/LS-G2, CMY-Y202S/302S-G2 Header: CMY-Y104/108/1010-G				

Notes:

*1,*2 Nominal conditions

	Indoor	Outdoor	Pipe length	Level difference
Cooling	27°C DB/19°C WB (81°F DB/66°F WB)	35°C DB/24°C WB (95°F DB/75°F WB)	7.5m (24-9/16ft.)	0m (0ft.)
Heating	20°C DB/68°F DB)	7°C DB/6°C WB(45°F DB/43°F WB)	7.5m (24-9/16ft.)	0m (0ft.)

*3 External static pressure option is available (30Pa, 60Pa / 3.1mmH₂O, 6.1mmH₂O).

*Nominal condition *1,*2 are subject to JIS B8615-1.

*Due to continuing improvement, above specification may be subject to change without notice.

OUTDOOR UNIT

Y Series

PUHY-P YSKB-A(-BS)



► Specifications

Model		PUHY-P950YSKB-A (-BS)			PUHY-P1000YSKB-A (-BS)			
Power source		3-phase 4-wire 380-400-415 V 50/60 Hz			3-phase 4-wire 380-400-415 V 50/60 Hz			
Cooling capacity (Nominal)	*1 kW	108.0			113.0			
	*1 BTU / h	368,500			385,600			
	Power input kW	33.85			35.20			
	Current input A	57.1-54.2-52.3			59.4-56.4-54.4			
EER		3.19			3.21			
Temp. range of cooling	Indoor W.B.	15.0~24.0°C (59~75°F)			15.0~24.0°C (59~75°F)			
	Outdoor D.B.	-5.0~52.0°C (23~126°F)			-5.0~52.0°C (23~126°F)			
Heating capacity (Nominal)	*2 kW	119.5			127.0			
	*2 BTU / h	407,700			433,300			
	Power input kW	34.63			36.70			
	Current input A	58.4-55.5-53.5			61.9-58.8-56.7			
COP		3.45			3.46			
Temp. range of heating	Indoor D.B.	15.0~27.0°C (59~81°F)			15.0~27.0°C (59~81°F)			
	Outdoor W.B.	-20.0~15.5°C (-4~60°F)			-20.0~15.5°C (-4~60°F)			
Indoor unit connectable	Total capacity	50~130% of outdoor unit capacity			50~130% of outdoor unit capacity			
	Model / Quantity	P15-P250/2~50			P15-P250/2~50			
Sound pressure level (measured in anechoic room)	dB <A>	66.5			66.5			
Sound power level (measured in anechoic room)	dB <A>	87			88			
Refrigerant piping diameter	Liquid pipe mm (in.)	19.05 (3/4) Brazed			19.05 (3/4) Brazed			
	Gas pipe mm (in.)	41.28 (1-5/8) Brazed			41.28 (1-5/8) Brazed			
Set Model								
Model		PUHY-P250YKB-A (-BS)	PUHY-P300YKB-A (-BS)	PUHY-P400YKB-A (-BS)	PUHY-P300YKB-A (-BS)	PUHY-P300YKB-A (-BS)	PUHY-P400YKB-A (-BS)	
FAN	Type x Quantity	Propeller fan x 1		Propeller fan x 1	Propeller fan x 1	Propeller fan x 1	Propeller fan x 1	
	Air flow rate	m ³ /min	175	210	210	210	210	210
		L/s	2,917	3,500	3,500	3,500	3,500	3,500
		cfm	6,179	7,415	7,415	7,415	7,415	7,415
	Driving mechanism	Inverter-control, Direct-driven by motor			Inverter-control, Direct-driven by motor			
Motor output kW	0.92 x 1	0.92 x 1	0.92 x 1	0.92 x 1	0.92 x 1	0.92 x 1	0.92 x 1	
*3 External static press.	0 Pa (0 mmH ₂ O)	0 Pa (0 mmH ₂ O)	0 Pa (0 mmH ₂ O)	0 Pa (0 mmH ₂ O)	0 Pa (0 mmH ₂ O)	0 Pa (0 mmH ₂ O)	0 Pa (0 mmH ₂ O)	
Compressor	Type x Quantity	Inverter scroll hermetic compressor			Inverter scroll hermetic compressor			
	Starting method	Inverter	Inverter	Inverter	Inverter	Inverter	Inverter	
	Motor output kW	6.9	8.1	10.8	8.1	8.1	10.8	
	Case heater kW	—	—	—	—	—	—	
External finish		Pre-coated galvanized steel sheets (+powder coating for -BS type) <MUNSELL 5Y 8/1 or similar>			Pre-coated galvanized steel sheets (+powder coating for -BS type) <MUNSELL 5Y 8/1 or similar>			
External dimension HxWxD	mm	1,710 (1,650 without legs) x 920 x 740	1,710 (1,650 without legs) x 1,220 x 740	1,710 (1,650 without legs) x 1,220 x 740	1,710 (1,650 without legs) x 1,220 x 740	1,710 (1,650 without legs) x 1,220 x 740	1,710 (1,650 without legs) x 1,220 x 740	
	in.	67-3/8 (65 without legs) x 36-1/4 x 29-3/16	67-3/8 (65 without legs) x 48-1/16 x 29-3/16	67-3/8 (65 without legs) x 48-1/16 x 29-3/16	67-3/8 (65 without legs) x 48-1/16 x 29-3/16	67-3/8 (65 without legs) x 48-1/16 x 29-3/16	67-3/8 (65 without legs) x 48-1/16 x 29-3/16	
Protection devices	High pressure protection	High pressure sensor, High pressure switch at 4.15 MPa (601 psi)			High pressure sensor, High pressure switch at 4.15 MPa (601 psi)			
	Inverter circuit (COMP./FAN)	Over-heat protection, Over-current protection			Over-heat protection, Over-current protection			
	Compressor	Over-heat protection	Over-heat protection	Over-heat protection	Over-heat protection	Over-heat protection	Over-heat protection	
Refrigerant	Fan motor	Over-current protection	Over-current protection	Over-current protection	Over-current protection	Over-current protection	Over-current protection	
	Type x original charge	R410A x 8.0 kg (18 lbs)	R410A x 11.5 kg (26 lbs)	R410A x 11.5 kg (26 lbs)	R410A x 11.5 kg (26 lbs)	R410A x 11.5 kg (26 lbs)	R410A x 11.5 kg (26 lbs)	
Net weight	kg (lbs)	199 (439)	251 (554)	251 (554)	251 (554)	251 (554)	251 (554)	
Heat exchanger		Salt-resistant cross fin & copper tube			Salt-resistant cross fin & copper tube			
Pipe between unit and distributor	Liquid pipe mm (in.)	9.52 (3/8) Brazed	12.7 (1/2) Brazed	15.88 (5/8) Brazed	12.7 (1/2) Brazed	12.7 (1/2) Brazed	15.88 (5/8) Brazed	
	Gas pipe mm (in.)	22.2 (7/8) Brazed	22.2 (7/8) Brazed	28.58 (1-1/8) Brazed	22.2 (7/8) Brazed	22.2 (7/8) Brazed	28.58 (1-1/8) Brazed	
Optional parts		Outdoor Twinning kit: CMY-Y300VBK3 Joint: CMY-Y102SS/LS-G2, CMY-Y202/302S-G2 Header: CMY-Y104/108/1010-G			Outdoor Twinning kit: CMY-Y300VBK3 Joint: CMY-Y102SS/LS-G2, CMY-Y202/302S-G2 Header: CMY-Y104/108/1010-G			

Notes:

*1,*2 Nominal conditions

	Indoor	Outdoor	Pipe length	Level difference
Cooling	27°C DB/19°C WB (81°F DB/66°F WB)	35°C DB/24°C WB (95°F DB/75°F WB)	7.5m (24-9/16ft.)	0m (0ft.)
Heating	20°C DB/68°F DB)	7°C DB/6°C WB(45°F DB/43°F WB)	7.5m (24-9/16ft.)	0m (0ft.)

*3 External static pressure option is available (30Pa, 60Pa / 3.1mmH₂O, 6.1mmH₂O).

*Nominal condition *1,*2 are subject to JIS B8615-1.

*Due to continuing improvement, above specification may be subject to change without notice.



OUTDOOR UNIT

Y Series

PUHY-P YSKB-A(-BS)



► Specifications

Model			PUHY-P1050YSKB-A (-BS)			PUHY-P1100YSKB-A (-BS)			
Power source			3-phase 4-wire 380-400-415 V 50/60 Hz			3-phase 4-wire 380-400-415 V 50/60 Hz			
Cooling capacity (Nominal)	*1	kW	118.0			124.0			
	*1	BTU / h	402,600			423,100			
	Power input	kW	37.34			39.74			
	Current input	A	63.0-59.8-57.7			67.0-63.7-61.4			
	EER	kW / kW	3.16			3.12			
Temp. range of cooling	Indoor	W.B.	15.0~24.0°C (59~75°F)			15.0~24.0°C (59~75°F)			
	Outdoor	D.B.	-5.0~52.0°C (23~126°F)			-5.0~52.0°C (23~126°F)			
Heating capacity (Nominal)	*2	kW	132.0			140.0			
	*2	BTU / h	450,400			477,700			
	Power input	kW	39.63			43.61			
	Current input	A	66.9-63.5-61.2			73.6-69.9-67.4			
	COP	kW / kW	3.33			3.21			
Temp. range of heating	Indoor	D.B.	15.0~27.0°C (59~81°F)			15.0~27.0°C (59~81°F)			
	Outdoor	W.B.	-20.0~15.5°C (-4~60°F)			-20.0~15.5°C (-4~60°F)			
Indoor unit connectable	Total capacity		50~130% of outdoor unit capacity			50~130% of outdoor unit capacity			
	Model / Quantity		P15-P250/2~50			P15-P250/2~50			
Sound pressure level (measured in anechoic room)		dB <A>	66.5			66.5			
Sound power level (measured in anechoic room)		dB <A>	88			88			
Refrigerant piping diameter	Liquid pipe	mm (in.)	19.05 (3/4) Brazed			19.05 (3/4) Brazed			
	Gas pipe	mm (in.)	41.28 (1-5/8) Brazed			41.28 (1-5/8) Brazed			
Set Model									
Model			PUHY-P300YKB-A (-BS)	PUHY-P350YKB-A (-BS)	PUHY-P400YKB-A (-BS)	PUHY-P350YKB-A (-BS)	PUHY-P350YKB-A (-BS)	PUHY-P400YKB-A (-BS)	
FAN	Type x Quantity		Propeller fan x 1		Propeller fan x 1		Propeller fan x 1		
	Air flow rate	m ³ /min	210		210		210		
		L/s	3,500		3,500		3,500		
		cfm	7,415		7,415		7,415		
	Driving mechanism		Inverter-control, Direct-driven by motor		Inverter-control, Direct-driven by motor		Inverter-control, Direct-driven by motor		
*3	Motor output	kW	0.92 x 1	0.92 x 1	0.92 x 1	0.92 x 1	0.92 x 1	0.92 x 1	
	External static press.		0 Pa (0 mmH ₂ O)	0 Pa (0 mmH ₂ O)	0 Pa (0 mmH ₂ O)	0 Pa (0 mmH ₂ O)	0 Pa (0 mmH ₂ O)	0 Pa (0 mmH ₂ O)	
Compressor	Type x Quantity		Inverter scroll hermetic compressor			Inverter scroll hermetic compressor			
	Starting method		Inverter	Inverter	Inverter	Inverter	Inverter	Inverter	
	Motor output		kW	8.1	10.5	10.8	10.5	10.5	10.8
	Case heater		kW	—	—	—	—	—	—
External finish			Pre-coated galvanized steel sheets (+powder coating for -BS type) <MUNSELL 5Y 8/1 or similar>			Pre-coated galvanized steel sheets (+powder coating for -BS type) <MUNSELL 5Y 8/1 or similar>			
External dimension HxWxD	mm		1,710 (1,650 without legs) x 1,220 x 740	1,710 (1,650 without legs) x 1,220 x 740	1,710 (1,650 without legs) x 1,220 x 740	1,710 (1,650 without legs) x 1,220 x 740	1,710 (1,650 without legs) x 1,220 x 740	1,710 (1,650 without legs) x 1,220 x 740	
	in.		67-3/8 (65 without legs) x 48-1/16 x 29-3/16	67-3/8 (65 without legs) x 48-1/16 x 29-3/16	67-3/8 (65 without legs) x 48-1/16 x 29-3/16	67-3/8 (65 without legs) x 48-1/16 x 29-3/16	67-3/8 (65 without legs) x 48-1/16 x 29-3/16	67-3/8 (65 without legs) x 48-1/16 x 29-3/16	
Protection devices	High pressure protection		High pressure sensor, High pressure switch at 4.15 MPa (601 psi)			High pressure sensor, High pressure switch at 4.15 MPa (601 psi)			
	Inverter circuit (COMP./FAN)		Over-heat protection, Over-current protection			Over-heat protection, Over-current protection			
	Compressor		Over-heat protection			Over-heat protection			
Fan motor		Over-current protection			Over-current protection				
Refrigerant		Type x original charge	R410A x 11.5 kg (26 lbs)	R410A x 11.5 kg (26 lbs)	R410A x 11.5 kg (26 lbs)	R410A x 11.5 kg (26 lbs)	R410A x 11.5 kg (26 lbs)	R410A x 11.5 kg (26 lbs)	
Net weight		kg (lbs)	251 (554)	251 (554)	251 (554)	251 (554)	251 (554)	251 (554)	
Heat exchanger			Salt-resistant cross fin & copper tube			Salt-resistant cross fin & copper tube			
Pipe between unit and distributor	Liquid pipe	mm (in.)	12.7 (1/2) Brazed	12.7 (1/2) Brazed	15.88 (5/8) Brazed	12.7 (1/2) Brazed	12.7 (1/2) Brazed	15.88 (5/8) Brazed	
	Gas pipe	mm (in.)	22.2 (7/8) Brazed	28.58 (1-1/8) Brazed	28.58 (1-1/8) Brazed	28.58 (1-1/8) Brazed	28.58 (1-1/8) Brazed	28.58 (1-1/8) Brazed	
Optional parts			Outdoor Twinning kit: CMY-Y300VBK3 Joint: CMY-Y102SS/LS-G2, CMY-Y202/302S-G2 Header: CMY-Y104/108/1010-G			Outdoor Twinning kit: CMY-Y300VBK3 Joint: CMY-Y102SS/LS-G2, CMY-Y202/302S-G2 Header: CMY-Y104/108/1010-G			

Notes:

*1,*2 Nominal conditions

	Indoor	Outdoor	Pipe length	Level difference
Cooling	27°C DB/19°C WB (81°F DB/66°F WB)	35°C DB/24°C WB (95°F DB/75°F WB)	7.5m (24-9/16ft.)	0m (0ft.)
Heating	20°C DB(68°F DB)	7°C DB/6°C WB(45°F DB/43°F WB)	7.5m (24-9/16ft.)	0m (0ft.)

*3 External static pressure option is available (30Pa, 60Pa / 3.1mmH₂O, 6.1mmH₂O).

*Nominal condition *1,*2 are subject to JIS B8615-1.

*Due to continuing improvement, above specification may be subject to change without notice.

OUTDOOR UNIT

Y Series

PUHY-P YSKB-A(-BS)



► Specifications

Model			PUHY-P1150YSKB-A (-BS)			PUHY-P1200YSKB-A (-BS)		
Power source			3-phase 4-wire 380-400-415 V 50/60 Hz			3-phase 4-wire 380-400-415 V 50/60 Hz		
Cooling capacity (Nominal)	*1	kW	130.0			136.0		
	*1	BTU / h	443,600			464,000		
		Power input kW	41.93			45.18		
		Current input A	70.7-67.2-64.8			76.2-72.4-69.8		
	EER	kW / kW	3.10			3.01		
Temp. range of cooling	Indoor	W.B.	15.0~24.0°C (59~75°F)			15.0~24.0°C (59~75°F)		
	Outdoor	D.B.	-5.0~52.0°C (23~126°F)			-5.0~52.0°C (23~126°F)		
Heating capacity (Nominal)	*2	kW	145.0			150.0		
	*2	BTU / h	494,700			511,800		
		Power input kW	45.45			47.31		
		Current input A	76.7-72.8-70.2			79.8-75.8-73.1		
	COP	kW / kW	3.19			3.17		
Temp. range of heating	Indoor	D.B.	15.0~27.0°C (59~81°F)			15.0~27.0°C (59~81°F)		
	Outdoor	W.B.	-20.0~15.5°C (-4~60°F)			-20.0~15.5°C (-4~60°F)		
Indoor unit connectable	Total capacity		50~130% of outdoor unit capacity			50~130% of outdoor unit capacity		
	Model / Quantity		P15-P250/2~50			P15-P250/2~50		
Sound pressure level (measured in anechoic room)		dB <A>	68.5			69		
Sound power level (measured in anechoic room)		dB <A>	88.5			88.5		
Refrigerant piping diameter	Liquid pipe	mm (in.)	19.05 (3/4) Brazed			19.05 (3/4) Brazed		
	Gas pipe	mm (in.)	41.28 (1-5/8) Brazed			41.28 (1-5/8) Brazed		
Set Model								
Model			PUHY-P350YKB-A (-BS)	PUHY-P350YKB-A (-BS)	PUHY-P450YKB-A (-BS)	PUHY-P350YKB-A (-BS)	PUHY-P400YKB-A (-BS)	PUHY-P450YKB-A (-BS)
FAN	Type x Quantity		Propeller fan x 1	Propeller fan x 1	Propeller fan x 2	Propeller fan x 1	Propeller fan x 1	Propeller fan x 2
	Air flow rate	m ³ /min	210	210	360	210	210	360
		L/s	3,500	3,500	6,000	3,500	3,500	6,000
		cfm	7,415	7,415	12,712	7,415	7,415	12,712
	Driving mechanism		Inverter-control, Direct-driven by motor			Inverter-control, Direct-driven by motor		
Motor output	kW	0.92 x 1	0.92 x 1	0.92 x 2	0.92 x 1	0.92 x 1	0.92 x 2	
*3	External static press.	0 Pa (0 mmH ₂ O)	0 Pa (0 mmH ₂ O)	0 Pa (0 mmH ₂ O)	0 Pa (0 mmH ₂ O)	0 Pa (0 mmH ₂ O)	0 Pa (0 mmH ₂ O)	
Compressor	Type x Quantity		Inverter scroll hermetic compressor			Inverter scroll hermetic compressor		
	Starting method		Inverter	Inverter	Inverter	Inverter	Inverter	Inverter
	Motor output	kW	10.5	10.5	12.4	10.5	10.8	12.4
	Case heater	kW	—	—	0.045	—	—	0.045
External finish			Pre-coated galvanized steel sheets (+powder coating for -BS type) <MUNSELL 5Y 8/1 or similar>			Pre-coated galvanized steel sheets (+powder coating for -BS type) <MUNSELL 5Y 8/1 or similar>		
External dimension HxWxD	mm		1,710 (1,650 without legs) x 1,220 x 740	1,710 (1,650 without legs) x 1,220 x 740	1,710 (1,650 without legs) x 1,750 x 740	1,710 (1,650 without legs) x 1,220 x 740	1,710 (1,650 without legs) x 1,220 x 740	1,710 (1,650 without legs) x 1,750 x 740
	in.		67-3/8 (65 without legs) x 48-1/16 x 29-3/16	67-3/8 (65 without legs) x 48-1/16 x 29-3/16	67-3/8 (65 without legs) x 68-15/16 x 29-3/16	67-3/8 (65 without legs) x 48-1/16 x 29-3/16	67-3/8 (65 without legs) x 48-1/16 x 29-3/16	67-3/8 (65 without legs) x 68-15/16 x 29-3/16
Protection devices	High pressure protection		High pressure sensor, High pressure switch at 4.15 MPa (601 psi)			High pressure sensor, High pressure switch at 4.15 MPa (601 psi)		
	Inverter circuit (COMP./FAN)		Over-heat protection, Over-current protection			Over-heat protection, Over-current protection		
	Compressor		Over-heat protection	Over-heat protection	Over-heat protection	Over-heat protection	Over-heat protection	Over-heat protection
Fan motor		Over-current protection	Over-current protection	Over-current protection	Over-current protection	Over-current protection	Over-current protection	
Refrigerant	Type x original charge	R410A x 11.5 kg (26 lbs)	R410A x 11.5 kg (26 lbs)	R410A x 11.8 kg (27 lbs)	R410A x 11.5 kg (26 lbs)	R410A x 11.5 kg (26 lbs)	R410A x 11.8 kg (27 lbs)	
Net weight	kg (lbs)	251 (554)	251 (554)	304 (671)	251 (554)	251 (554)	304 (671)	
Heat exchanger			Salt-resistant cross fin & copper tube			Salt-resistant cross fin & copper tube		
Pipe between unit and distributor	Liquid pipe	mm (in.)	12.7 (1/2) Brazed	12.7 (1/2) Brazed	15.88 (5/8) Brazed	12.7 (1/2) Brazed	15.88 (5/8) Brazed	15.88 (5/8) Brazed
	Gas pipe	mm (in.)	28.58 (1-1/8) Brazed	28.58 (1-1/8) Brazed	28.58 (1-1/8) Brazed	28.58 (1-1/8) Brazed	28.58 (1-1/8) Brazed	28.58 (1-1/8) Brazed
Optional parts			Outdoor Twinning kit: CMY-Y300VBK3 Joint: CMY-Y102SS/LS-G2, CMY-Y202/302S-G2 Header: CMY-Y104/108/1010-G			Outdoor Twinning kit: CMY-Y300VBK3 Joint: CMY-Y102SS/LS-G2, CMY-Y202/302S-G2 Header: CMY-Y104/108/1010-G		

Notes:

*1,*2 Nominal conditions

	Indoor	Outdoor	Pipe length	Level difference
Cooling	27°C DB/19°C WB (81°F DB/66°F WB)	35°C DB/24°C WB (95°F DB/75°F WB)	7.5m (24-9/16ft.)	0m (0ft.)
Heating	20°C DB(68°F DB)	7°C DB/6°C WB(45°F DB/43°F WB)	7.5m (24-9/16ft.)	0m (0ft.)

*3 External static pressure option is available (30Pa, 60Pa / 3.1mmH₂O, 6.1mmH₂O).

*Nominal condition *1,*2 are subject to JIS B8615-1.

*Due to continuing improvement, above specification may be subject to change without notice.

OUTDOOR UNIT

Y Series

PUHY-P YSKB-A(-BS)



► Specifications

Model			PUHY-P1250YSKB-A (-BS)			PUHY-P1300YSKB-A (-BS)		
Power source			3-phase 4-wire 380-400-415 V 50/60 Hz			3-phase 4-wire 380-400-415 V 50/60 Hz		
Cooling capacity (Nominal)	*1	kW	140.0			146.0		
	*1	BTU / h	477,700			498,200		
		Power input kW	46.82			50.51		
		Current input A	79.0-75.0-72.3			85.2-81.0-78.0		
	EER	kW / kW	2.99			2.89		
Temp. range of cooling	Indoor	W.B.	15.0~24.0°C (59~75°F)			15.0~24.0°C (59~75°F)		
	Outdoor	D.B.	-5.0~52.0°C (23~126°F)			-5.0~52.0°C (23~126°F)		
Heating capacity (Nominal)	*2	kW	156.5			163.0		
	*2	BTU / h	534,000			556,200		
		Power input kW	49.52			51.91		
		Current input A	83.5-79.4-76.5			87.6-83.2-80.2		
	COP	kW / kW	3.16			3.14		
Temp. range of heating	Indoor	D.B.	15.0~27.0°C (59~81°F)			15.0~27.0°C (59~81°F)		
	Outdoor	W.B.	-20.0~15.5°C (-4~60°F)			-20.0~15.5°C (-4~60°F)		
Indoor unit connectable	Total capacity		50~130% of outdoor unit capacity			50~130% of outdoor unit capacity		
	Model / Quantity		P15-P250/2~50			P15-P250/2~50		
Sound pressure level (measured in anechoic room)	dB <A>		70			70		
Sound power level (measured in anechoic room)	dB <A>		89.5			89.5		
Refrigerant piping diameter	Liquid pipe	mm (in.)	19.05 (3/4) Brazed			19.05 (3/4) Brazed		
	Gas pipe	mm (in.)	41.28 (1-5/8) Brazed			41.28 (1-5/8) Brazed		
Set Model								
Model			PUHY-P350YKB-A (-BS)	PUHY-P450YKB-A (-BS)	PUHY-P450YKB-A (-BS)	PUHY-P400YKB-A (-BS)	PUHY-P450YKB-A (-BS)	PUHY-P450YKB-A (-BS)
FAN	Type x Quantity		Propeller fan x 1	Propeller fan x 2	Propeller fan x 2	Propeller fan x 1	Propeller fan x 2	Propeller fan x 2
	Air flow rate	m ³ /min	210	360	360	210	360	360
		L/s	3,500	6,000	6,000	3,500	6,000	6,000
		cfm	7,415	12,712	12,712	7,415	12,712	12,712
	Driving mechanism		Inverter-control, Direct-driven by motor			Inverter-control, Direct-driven by motor		
	Motor output	kW	0.92 x 1	0.92 x 2	0.92 x 2	0.92 x 1	0.92 x 2	0.92 x 2
*3	External static press.	0 Pa (0 mmH ₂ O)	0 Pa (0 mmH ₂ O)	0 Pa (0 mmH ₂ O)	0 Pa (0 mmH ₂ O)	0 Pa (0 mmH ₂ O)	0 Pa (0 mmH ₂ O)	
Compressor	Type x Quantity		Inverter scroll hermetic compressor			Inverter scroll hermetic compressor		
	Starting method		Inverter	Inverter	Inverter	Inverter	Inverter	Inverter
	Motor output	kW	10.5	12.4	12.4	10.8	12.4	12.4
	Case heater	kW	—	0.045	0.045	—	0.045	0.045
External finish			Pre-coated galvanized steel sheets (+powder coating for -BS type) <MUNSELL 5Y 8/1 or similar>			Pre-coated galvanized steel sheets (+powder coating for -BS type) <MUNSELL 5Y 8/1 or similar>		
External dimension HxWxD	mm	1,710 (1,650 without legs) x 1,220 x 740	1,710 (1,650 without legs) x 1,750 x 740	1,710 (1,650 without legs) x 1,750 x 740	1,710 (1,650 without legs) x 1,220 x 740	1,710 (1,650 without legs) x 1,750 x 740	1,710 (1,650 without legs) x 1,750 x 740	
	in.	67-3/8 (65 without legs) x 48-1/16 x 29-3/16	67-3/8 (65 without legs) x 68-15/16 x 29-3/16	67-3/8 (65 without legs) x 68-15/16 x 29-3/16	67-3/8 (65 without legs) x 48-1/16 x 29-3/16	67-3/8 (65 without legs) x 68-15/16 x 29-3/16	67-3/8 (65 without legs) x 68-15/16 x 29-3/16	
Protection devices	High pressure protection	High pressure sensor, High pressure switch at 4.15 MPa (601 psi)			High pressure sensor, High pressure switch at 4.15 MPa (601 psi)			
	Inverter circuit (COMP./FAN)	Over-heat protection, Over-current protection			Over-heat protection, Over-current protection			
	Compressor	Over-heat protection			Over-heat protection			
Refrigerant	Fan motor	Over-current protection			Over-current protection			
	Type x original charge	R410A x 11.5 kg (26 lbs)	R410A x 11.8 kg (27 lbs)	R410A x 11.8 kg (27 lbs)	R410A x 11.5 kg (26 lbs)	R410A x 11.8 kg (27 lbs)	R410A x 11.8 kg (27 lbs)	
Net weight	kg (lbs)	251 (554)	304 (671)	304 (671)	251 (554)	304 (671)	304 (671)	
Heat exchanger			Salt-resistant cross fin & copper tube			Salt-resistant cross fin & copper tube		
Pipe between unit and distributor	Liquid pipe	mm (in.)	12.7 (1/2) Brazed	15.88 (5/8) Brazed	15.88 (5/8) Brazed	15.88 (5/8) Brazed	15.88 (5/8) Brazed	15.88 (5/8) Brazed
	Gas pipe	mm (in.)	28.58 (1-1/8) Brazed	28.58 (1-1/8) Brazed	28.58 (1-1/8) Brazed	28.58 (1-1/8) Brazed	28.58 (1-1/8) Brazed	28.58 (1-1/8) Brazed
Optional parts			Outdoor Twinning kit: CMY-Y300VBK3 Joint: CMY-Y102SS/LS-G2, CMY-Y202/302S-G2 Header: CMY-Y104/108/1010-G			Outdoor Twinning kit: CMY-Y300VBK3 Joint: CMY-Y102SS/LS-G2, CMY-Y202/302S-G2 Header: CMY-Y104/108/1010-G		

Notes:

*1,*2 Nominal conditions

	Indoor	Outdoor	Pipe length	Level difference
Cooling	27°C DB/19°C WB (81°F DB/66°F WB)	35°C DB/24°C WB (95°F DB/75°F WB)	7.5m (24-9/16ft.)	0m (0ft.)
Heating	20°C DB/68°F DB)	7°C DB/6°C WB(45°F DB/43°F WB)	7.5m (24-9/16ft.)	0m (0ft.)

*3 External static pressure option is available (30Pa, 60Pa / 3.1mmH₂O, 6.1mmH₂O).

*Nominal condition *1,*2 are subject to JIS B8615-1.

*Due to continuing improvement, above specification may be subject to change without notice.

OUTDOOR UNIT

Y Series

PUHY-P YSKB-A(-BS)



► Specifications

Model		PUHY-P1350YSKB-A (-BS)			
Power source		3-phase 4-wire 380-400-415 V 50/60 Hz			
Cooling capacity (Nominal)	*1 kW	150.0			
	*1 BTU / h	511,800			
	Power input kW	52.08			
	Current input A	87.9-83.5-80.5			
	EER kW / kW	2.88			
Temp. range of cooling	Indoor W.B.	15.0~24.0°C (59~75°F)			
	Outdoor D.B.	-5.0~52.0°C (23~126°F)			
Heating capacity (Nominal)	*2 kW	168.0			
	*2 BTU / h	573,200			
	Power input kW	53.84			
	Current input A	90.8-86.3-83.2			
	COP kW / kW	3.12			
Temp. range of heating	Indoor D.B.	15.0~27.0°C (59~81°F)			
	Outdoor W.B.	-20.0~15.5°C (-4~60°F)			
Indoor unit connectable	Total capacity	50~130% of outdoor unit capacity			
	Model / Quantity	P15-P250/2~50			
Sound pressure level (measured in anechoic room)	dB <A>	71			
Sound power level (measured in anechoic room)	dB <A>	90			
Refrigerant piping diameter	Liquid pipe mm (in.)	19.05 (3/4) Brazed			
	Gas pipe mm (in.)	41.28 (1-5/8) Brazed			
Set Model					
Model		PUHY-P450YKB-A (-BS)	PUHY-P450YKB-A (-BS)	PUHY-P450YKB-A (-BS)	
FAN	Type x Quantity	Propeller fan x 2			
	Air flow rate	m ³ /min	360	360	360
		L/s	6,000	6,000	6,000
		cfm	12,712	12,712	12,712
	Driving mechanism	Inverter-control, Direct-driven by motor			
	Motor output kW	0.92 x 2			
*3 External static press.	0 Pa (0 mmH ₂ O)				
Compressor	Type x Quantity	Inverter scroll hermetic compressor			
	Starting method	Inverter			
	Motor output kW	12.4			
	Case heater kW	0.045			
External finish		Pre-coated galvanized steel sheets (+powder coating for -BS type) <MUNSELL 5Y 8/1 or similar>	Pre-coated galvanized steel sheets (+powder coating for -BS type) <MUNSELL 5Y 8/1 or similar>	Pre-coated galvanized steel sheets (+powder coating for -BS type) <MUNSELL 5Y 8/1 or similar>	
External dimension HxWxD	mm	1,710 (1,650 without legs) x 1,750 x 740	1,710 (1,650 without legs) x 1,750 x 740	1,710 (1,650 without legs) x 1,750 x 740	
	in.	67-3/8 (65 without legs) x 68-15/16 x 29-3/16	67-3/8 (65 without legs) x 68-15/16 x 29-3/16	67-3/8 (65 without legs) x 68-15/16 x 29-3/16	
Protection devices	High pressure protection	High pressure sensor, High pressure switch at 4.15 MPa (601 psi)			
	Inverter circuit (COMP./FAN)	Over-heat protection, Over-current protection			
	Compressor	Over-heat protection			
	Fan motor	Over-current protection			
Refrigerant	Type x original charge	R410A x 11.8 kg (27 lbs)			
Net weight	kg (lbs)	304 (671)			
Heat exchanger		Salt-resistant cross fin & copper tube			
Pipe between unit and distributor	Liquid pipe mm (in.)	15.88 (5/8) Brazed			
	Gas pipe mm (in.)	28.58 (1-1/8) Brazed			
Optional parts		Outdoor Twinning kit: CMY-Y300VBK3 Joint: CMY-Y102SS/LS-G2, CMY-Y202/302S-G2 Header: CMY-Y104/108/1010-G			

Notes:

*1,*2 Nominal conditions

	Indoor	Outdoor	Pipe length	Level difference
Cooling	27°C DB/19°C WB (81°F DB/66°F WB)	35°C DB/24°C WB (95°F DB/75°F WB)	7.5m (24-9/16ft.)	0m (0ft.)
Heating	20°C DB(68°F DB)	7°C DB/6°C WB(45°F DB/43°F WB)	7.5m (24-9/16ft.)	0m (0ft.)

*3 External static pressure option is available (30Pa, 60Pa / 3.1mmH₂O, 6.1mmH₂O).

*Nominal condition *1,*2 are subject to JIS B8615-1.

*Due to continuing improvement, above specification may be subject to change without notice.



OUTDOOR UNIT Y Series - High COP PUHY-EP YLM-A1(-BS)



► Specifications

Model	PUHY-EP200YLM-A (-BS)		PUHY-EP250YLM-A (-BS)		PUHY-EP300YLM-A (-BS)		
Power source	3-phase 4-wire 380-400-415 V 50/60 Hz		3-phase 4-wire 380-400-415 V 50/60 Hz		3-phase 4-wire 380-400-415 V 50/60 Hz		
Cooling capacity (Nominal)	*1 kW	22.4	28.0	33.5			
	*1 BTU / h	76,400	95,500	114,300			
	Power input kW	5.19	6.89	8.56			
	Current input A	8.7-8.3-8.0	11.6-11.0-10.6	14.4-13.7-13.2			
	EER kW / kW	4.31	4.06	3.91			
Temp. range of cooling	Indoor W.B.	15.0~24.0°C (59~75°F)	15.0~24.0°C (59~75°F)	15.0~24.0°C (59~75°F)			
	Outdoor D.B.	-5.0~52.0°C (23~126°F)	-5.0~52.0°C (23~126°F)	-5.0~52.0°C (23~126°F)			
Heating capacity (Nominal)	*2 kW	25.0	31.5	37.5			
	*2 BTU / h	85,300	107,500	128,000			
	Power input kW	5.73	7.68	9.16			
	Current input A	9.6-9.1-8.8	12.9-12.3-11.8	15.4-14.6-14.1			
	COP kW / kW	4.36	4.10	4.09			
Temp. range of heating	Indoor D.B.	15.0~27.0°C (59~81°F)	15.0~27.0°C (59~81°F)	15.0~27.0°C (59~81°F)			
	Outdoor W.B.	-20.0~15.5°C (-4~60°F)	-20.0~15.5°C (-4~60°F)	-20.0~15.5°C (-4~60°F)			
Indoor unit connectable	Total capacity	50~130% of outdoor unit capacity	50~130% of outdoor unit capacity	50~130% of outdoor unit capacity			
	Model / Quantity	P15-P250/1~17	P15-P250/1~21	P15-P250/1~26			
Sound pressure level (measured in anechoic room)	dB <A>	57	60	61			
Sound power level (measured in anechoic room)	dB <A>	79.5	80	82			
Refrigerant piping diameter	Liquid pipe mm (in.)	9.52 (3/8) Brazed	9.52 (3/8) Brazed (12.7 (1/2) Brazed, farthest length >= 90 m)	9.52 (3/8) Brazed (12.7 (1/2) Brazed, farthest length >= 40 m)			
	Gas pipe mm (in.)	22.2 (7/8) Brazed	22.2 (7/8) Brazed	28.58 (1-1/8) Brazed			
FAN	Type x Quantity	Propeller fan x 1	Propeller fan x 1	Propeller fan x 1			
	Air flow rate	m ³ /min	175	175	200		
		L/s	2,917	2,917	3,333		
		cfm	6,179	6,179	7,062		
	Driving mechanism	Inverter-control, Direct-driven by motor	Inverter-control, Direct-driven by motor	Inverter-control, Direct-driven by motor			
	Motor output kW	0.92 x 1	0.92 x 1	0.92 x 1			
	*3 External static press.	0 Pa (0 mmH ₂ O)	0 Pa (0 mmH ₂ O)	0 Pa (0 mmH ₂ O)			
Compressor	Type x Quantity	Inverter scroll hermetic compressor	Inverter scroll hermetic compressor	Inverter scroll hermetic compressor			
	Starting method	Inverter	Inverter	Inverter			
	Motor output kW	5.6	6.9	8.1			
	Case heater kW	-	-	-			
External finish	Pre-coated galvanized steel sheets (+powder coating for -BS type) <MUNSELL 5Y 8/1 or similar>		Pre-coated galvanized steel sheets (+powder coating for -BS type) <MUNSELL 5Y 8/1 or similar>	Pre-coated galvanized steel sheets (+powder coating for -BS type) <MUNSELL 5Y 8/1 or similar>			
External dimension HxWxD	mm	1,710 (1,650 without legs) x 920 x 740	1,710 (1,650 without legs) x 920 x 740	1,710 (1,650 without legs) x 1,220 x 740			
	in.	67-3/8 (65 without legs) x 36-1/4 x 29-3/16	67-3/8 (65 without legs) x 36-1/4 x 29-3/16	67-3/8 (65 without legs) x 48-1/16 x 29-3/16			
Protection devices	High pressure protection	High pressure sensor, High pressure switch at 4.15 MPa (601 psi)	High pressure sensor, High pressure switch at 4.15 MPa (601 psi)	High pressure sensor, High pressure switch at 4.15 MPa (601 psi)			
	Inverter circuit (COMP./FAN)	Over-heat protection, Over-current protection	Over-heat protection, Over-current protection	Over-heat protection, Over-current protection			
	Compressor	Over-heat protection	Over-heat protection	Over-heat protection			
	Fan motor	Over-current protection	Over-current protection	Over-current protection			
Refrigerant	Type x original charge	R410A x 7.5 kg (17 lbs)	R410A x 7.5 kg (17 lbs)	R410A x 10.3 kg (23 lbs)			
Net weight	kg (lbs)	208 (459)	208 (459)	252 (556)			
Heat exchanger	Salt-resistant cross fin & aluminium tube		Salt-resistant cross fin & aluminium tube	Salt-resistant cross fin & aluminium tube			
Optional parts	Joint: CMY-Y102SS/LS-G2		Joint: CMY-Y102SS/LS-G2	Joint: CMY-Y102SS/LS-G2			
	Header: CMY-Y104/108/1010-G		Header: CMY-Y104/108/1010-G	Header: CMY-Y104/108/1010-G			



Notes:

*1,*2 Nominal conditions

	Indoor	Outdoor	Pipe length	Level difference
Cooling	27°C DB/19°C WB (81°F DB/66°F WB)	35°C DB/24°C WB (95°F DB/75°F WB)	7.5m (24-9/16ft.)	0m (0ft.)
Heating	20°C DB/68°F DB)	7°C DB/6°C WB(45°F DB/43°F WB)	7.5m (24-9/16ft.)	0m (0ft.)

*3 External static pressure option is available (30Pa, 60Pa / 3.1mmH₂O, 6.1mmH₂O).

*Nominal condition *1,*2 are subject to JIS B8615-1.

*Due to continuing improvement, above specification may be subject to change without notice.

OUTDOOR UNIT Y Series - High COP PUHY-EP YLM-A1(-BS)



► Specifications

Model	PUHY-EP350YLM-A (-BS)		PUHY-EP400YLM-A (-BS)		PUHY-EP450YLM-A (-BS)	
Power source	3-phase 4-wire 380-400-415 V 50/60 Hz		3-phase 4-wire 380-400-415 V 50/60 Hz		3-phase 4-wire 380-400-415 V 50/60 Hz	
Cooling capacity (Nominal)	*1	kW	40.0		50.0	
	*1	BTU / h	136,500		170,600	
		Power input kW	11.69		14.79	
		Current input A	19.7-18.7-18.0		24.9-23.7-22.8	
		EER kW / kW	3.42		3.38	
Temp. range of cooling	Indoor	W.B.	15.0~24.0°C (59~75°F)		15.0~24.0°C (59~75°F)	
	Outdoor	D.B.	-5.0~52.0°C (23~126°F)		-5.0~52.0°C (23~126°F)	
Heating capacity (Nominal)	*2	kW	45.0		56.0	
	*2	BTU / h	153,500		191,100	
		Power input kW	12.53		16.09	
		Current input A	21.1-20.0-19.3		27.1-25.8-24.8	
		COP kW / kW	3.59		3.48	
Temp. range of heating	Indoor	D.B.	15.0~27.0°C (59~81°F)		15.0~27.0°C (59~81°F)	
	Outdoor	W.B.	-20.0~15.5°C (-4~60°F)		-20.0~15.5°C (-4~60°F)	
Indoor unit connectable	Total capacity	50~130% of outdoor unit capacity		50~130% of outdoor unit capacity		
	Model / Quantity	P15-P250/1~30		P15-P250/1~34		
Sound pressure level (measured in anechoic room)		dB <A>	61		63	
Sound power level (measured in anechoic room)		dB <A>	82.5		83	
Refrigerant piping diameter	Liquid pipe	mm (in.)	12.7 (1/2) Braze		15.88 (5/8) Braze	
	Gas pipe	mm (in.)	28.58 (1-1/8) Braze		28.58 (1-1/8) Braze	
FAN	Type x Quantity	Propeller fan x 1		Propeller fan x 2		
	Air flow rate	m ³ /min	200		370	
		L/s	3,333		6,167	
		cfm	7,062		13,065	
	Driving mechanism	Inverter-control, Direct-driven by motor		Inverter-control, Direct-driven by motor		
	Motor output	kW	0.92 x 1		0.92 x 2	
	*3 External static press.	0 Pa (0 mmH ₂ O)		0 Pa (0 mmH ₂ O)		0 Pa (0 mmH ₂ O)
Compressor	Type x Quantity	Inverter scroll hermetic compressor		Inverter scroll hermetic compressor		
	Starting method	Inverter		Inverter		
	Motor output	kW	10.5		12.4	
	Case heater	kW	-		-	
External finish	Pre-coated galvanized steel sheets (+powder coating for -BS type) <MUNSELL 5Y 8/1 or similar>		Pre-coated galvanized steel sheets (+powder coating for -BS type) <MUNSELL 5Y 8/1 or similar>		Pre-coated galvanized steel sheets (+powder coating for -BS type) <MUNSELL 5Y 8/1 or similar>	
External dimension HxWxD	mm	1,710 (1,650 without legs) x 1,220 x 740		1,710 (1,650 without legs) x 1,750 x 740		
	in.	67-3/8 (65 without legs) x 48-1/16 x 29-3/16		67-3/8 (65 without legs) x 68-15/16 x 29-3/16		
Protection devices	High pressure protection	High pressure sensor, High pressure switch at 4.15 MPa (601 psi)		High pressure sensor, High pressure switch at 4.15 MPa (601 psi)		
	Inverter circuit (COMP./FAN)	Over-heat protection, Over-current protection		Over-heat protection, Over-current protection		
	Compressor	Over-heat protection		Over-heat protection		
	Fan motor	Over-current protection		Over-current protection		
Refrigerant	Type x original charge	R410A x 10.3 kg (23 lbs)		R410A x 11.8 kg (27 lbs)		
Net weight	kg (lbs)	252 (556)		318 (702)		
Heat exchanger	Salt-resistant cross fin & aluminium tube		Salt-resistant cross fin & aluminium tube		Salt-resistant cross fin & aluminium tube	
Optional parts	Joint: CMY-Y102SS/LS-G2, CMY-Y202S-G2 Header: CMY-Y104/108/1010-G		Joint: CMY-Y102SS/LS-G2, CMY-Y202S-G2 Header: CMY-Y104/108/1010-G		Joint: CMY-Y102SS/LS-G2, CMY-Y202S-G2 Header: CMY-Y104/108/1010-G	



Notes:

*1,*2 Nominal conditions

	Indoor	Outdoor	Pipe length	Level difference
Cooling	27°C DB/19°C WB (81°F DB/66°F WB)	35°C DB/24°C WB (95°F DB/75°F WB)	7.5m (24-9/16ft.)	0m (0ft.)
Heating	20°C DB(68°F DB)	7°C DB/6°C WB(45°F DB/43°F WB)	7.5m (24-9/16ft.)	0m (0ft.)

*3 External static pressure option is available (30Pa, 60Pa / 3.1mmH₂O, 6.1mmH₂O).

*Nominal condition *1,*2 are subject to JIS B8615-1.

*Due to continuing improvement, above specification may be subject to change without notice.

OUTDOOR UNIT Y Series - High COP PUHY-EP YSLM-A1(-BS)



► Specifications

Model			PUHY-EP500YSLM-A (-BS)		PUHY-EP550YSLM-A (-BS)		PUHY-EP600YSLM-A (-BS)	
Power source			3-phase 4-wire 380-400-415 V 50/60 Hz		3-phase 4-wire 380-400-415 V 50/60 Hz		3-phase 4-wire 380-400-415 V 50/60 Hz	
Cooling capacity (Nominal)	*1	kW	56.0		63.0		69.0	
	*1	BTU / h	191,100		215,000		235,400	
		Power input kW	14.50		16.62		18.59	
		Current input A	24.4-23.2-22.4		28.0-26.6-25.6		31.3-29.8-28.7	
		EER kW / kW	3.86		3.79		3.71	
Temp. range of cooling	Indoor	W.B.	15.0~24.0°C (59~75°F)		15.0~24.0°C (59~75°F)		15.0~24.0°C (59~75°F)	
	Outdoor	D.B.	-5.0~52.0°C (23~126°F)		-5.0~52.0°C (23~126°F)		-5.0~52.0°C (23~126°F)	
Heating capacity (Nominal)	*2	kW	63.0		69.0		76.5	
	*2	BTU / h	215,000		235,400		261,000	
		Power input kW	16.15		17.73		19.66	
		Current input A	27.2-25.9-24.9		29.9-28.4-27.4		33.1-31.5-30.3	
		COP kW / kW	3.90		3.89		3.89	
Temp. range of heating	Indoor	D.B.	15.0~27.0°C (59~81°F)		15.0~27.0°C (59~81°F)		15.0~27.0°C (59~81°F)	
	Outdoor	W.B.	-20.0~15.5°C (-4~60°F)		-20.0~15.5°C (-4~60°F)		-20.0~15.5°C (-4~60°F)	
Indoor unit connectable	Total capacity		50~130% of outdoor unit capacity		50~130% of outdoor unit capacity		50~130% of outdoor unit capacity	
	Model / Quantity		P15-P250/1~43		P15-P250/2~47		P15-P250/2~50	
Sound pressure level (measured in anechoic room)		dB <A>	63		63.5		64	
Sound power level (measured in anechoic room)		dB <A>	83		84.5		85	
Refrigerant piping diameter	Liquid pipe	mm (in.)	15.88 (5/8) Brazed		15.88 (5/8) Brazed		15.88 (5/8) Brazed	
	Gas pipe	mm (in.)	28.58 (1-1/8) Brazed		28.58 (1-1/8) Brazed		28.58 (1-1/8) Brazed	
Set Model								
Model			PUHY-EP250YLM-A (-BS)	PUHY-EP250YLM-A (-BS)	PUHY-EP250YLM-A (-BS)	PUHY-EP300YLM-A (-BS)	PUHY-EP300YLM-A (-BS)	PUHY-EP300YLM-A (-BS)
FAN	Type x Quantity		Propeller fan x 1		Propeller fan x 1		Propeller fan x 1	
	Air flow rate	m ³ /min	175		175		200	
		L/s	2,917		2,917		3,333	
		cfm	6,179		6,179		7,062	
	Driving mechanism		Inverter-control, Direct-driven by motor		Inverter-control, Direct-driven by motor		Inverter-control, Direct-driven by motor	
Compressor	Motor output		0.92 x 1		0.92 x 1		0.92 x 1	
	External static press.		0 Pa (0 mmH ₂ O)		0 Pa (0 mmH ₂ O)		0 Pa (0 mmH ₂ O)	
	Starting method		Inverter		Inverter		Inverter	
Motor output		6.9		6.9		8.1		
Case heater		kW		-		-		
External finish			Pre-coated galvanized steel sheets (+powder coating for -BS type) <MUNSELL 5Y 8/1 or similar>		Pre-coated galvanized steel sheets (+powder coating for -BS type) <MUNSELL 5Y 8/1 or similar>		Pre-coated galvanized steel sheets (+powder coating for -BS type) <MUNSELL 5Y 8/1 or similar>	
External dimension HxWxD	mm		1,710 (1,650 without legs) x 920 x 740		1,710 (1,650 without legs) x 920 x 740		1,710 (1,650 without legs) x 1,220 x 740	
	in.		67-3/8 (65 without legs) x 36-1/4 x 29-3/16		67-3/8 (65 without legs) x 36-1/4 x 29-3/16		67-3/8 (65 without legs) x 48-1/16 x 29-3/16	
Protection devices	High pressure protection		High pressure sensor, High pressure switch at 4.15 MPa (601 psi)		High pressure sensor, High pressure switch at 4.15 MPa (601 psi)		High pressure sensor, High pressure switch at 4.15 MPa (601 psi)	
	Inverter circuit (COMP./FAN)		Over-heat protection, Over-current protection		Over-heat protection, Over-current protection		Over-heat protection, Over-current protection	
	Compressor		Over-heat protection Over-heat protection		Over-heat protection Over-heat protection		Over-heat protection Over-heat protection	
	Fan motor		Over-current protection		Over-current protection		Over-current protection	
Refrigerant	Type x original charge		R410A x 7.5 kg (17 lbs)		R410A x 7.5 kg (17 lbs)		R410A x 10.3 kg (23 lbs)	
Net weight	kg (lbs)		208 (459)		208 (459)		252 (556)	
Heat exchanger			Salt-resistant cross fin & aluminium tube		Salt-resistant cross fin & aluminium tube		Salt-resistant cross fin & aluminium tube	
Pipe between unit and distributor	Liquid pipe	mm (in.)	9.52 (3/8) Brazed		9.52 (3/8) Brazed		12.7 (1/2) Brazed	
	Gas pipe	mm (in.)	22.2 (7/8) Brazed		22.2 (7/8) Brazed		28.58 (1-1/8) Brazed	
Optional parts			Outdoor Twinning kit: CMY-Y100VBK3 Joint: CMY-Y102SS/LS-G2, CMY-Y202S-G2 Header: CMY-Y104/108/1010-G		Outdoor Twinning kit: CMY-Y100VBK3 Joint: CMY-Y102SS/LS-G2, CMY-Y202S-G2 Header: CMY-Y104/108/1010-G		Outdoor Twinning kit: CMY-Y100VBK3 Joint: CMY-Y102SS/LS-G2, CMY-Y202S-G2 Header: CMY-Y104/108/1010-G	



Notes:

*1,*2 Nominal conditions

	Indoor	Outdoor	Pipe length	Level difference
Cooling	27°C DB/19°C WB (81°F DB/66°F WB)	35°C DB/24°C WB (95°F DB/75°F WB)	7.5m (24-9/16ft.)	0m (0ft.)
Heating	20°C DB(68°F DB)	7°C DB/6°C WB(45°F DB/43°F WB)	7.5m (24-9/16ft.)	0m (0ft.)

*3 External static pressure option is available (30Pa, 60Pa / 3.1mmH₂O, 6.1mmH₂O).

*Nominal condition *1,*2 are subject to JIS B8615-1.

*Due to continuing improvement, above specification may be subject to change without notice.

OUTDOOR UNIT Y Series - High COP PUHY-EP YSLM-A1(-BS)



► Specifications

Model			PUHY-EP650YSLM-A (-BS)			PUHY-EP700YSLM-A (-BS)		
Power source			3-phase 4-wire 380-400-415 V 50/60 Hz			3-phase 4-wire 380-400-415 V 50/60 Hz		
Cooling capacity (Nominal)	*1	kW	73.0			80.0		
	*1	BTU / h	249,100			273,000		
	Power input	kW	18.15			20.15		
	Current input	A	30.6-29.1-28.0			34.0-32.3-31.1		
	EER	kW / kW	4.02			3.97		
Temp. range of cooling	Indoor	W.B.	15.0~24.0°C (59~75°F)			15.0~24.0°C (59~75°F)		
	Outdoor	D.B.	-5.0~52.0°C (23~126°F)			-5.0~52.0°C (23~126°F)		
Heating capacity (Nominal)	*2	kW	81.5			88.0		
	*2	BTU / h	278,100			300,300		
	Power input	kW	20.07			21.67		
	Current input	A	33.8-32.1-31.0			36.5-34.7-33.4		
	COP	kW / kW	4.06			4.06		
Temp. range of heating	Indoor	D.B.	15.0~27.0°C (59~81°F)			15.0~27.0°C (59~81°F)		
	Outdoor	W.B.	-20.0~15.5°C (-4~60°F)			-20.0~15.5°C (-4~60°F)		
Indoor unit connectable	Total capacity		50~130% of outdoor unit capacity			50~130% of outdoor unit capacity		
	Model / Quantity		P15-P250/2~50			P15-P250/2~50		
Sound pressure level (measured in anechoic room)		dB <A>	63			63.5		
Sound power level (measured in anechoic room)		dB <A>	84.5			85.5		
Refrigerant piping diameter	Liquid pipe	mm (in.)	15.88 (5/8) Brazed			19.05 (3/4) Brazed		
	Gas pipe	mm (in.)	28.58 (1-1/8) Brazed			34.93 (1-3/8) Brazed		
Set Model								
Model			PUHY-EP200YLM-A (-BS)	PUHY-EP200YLM-A (-BS)	PUHY-EP250YLM-A (-BS)	PUHY-EP200YLM-A (-BS)	PUHY-EP200YLM-A (-BS)	PUHY-EP300YLM-A (-BS)
FAN	Type x Quantity		Propeller fan x 1		Propeller fan x 1		Propeller fan x 1	
	Air flow rate	m ³ /min	175		175		175	
		L/s	2,917		2,917		2,917	
		cfm	6,179		6,179		6,179	
	Driving mechanism		Inverter-control, Direct-driven by motor			Inverter-control, Direct-driven by motor		
*3	Motor output	kW	0.92 x 1		0.92 x 1		0.92 x 1	
	External static press.		0 Pa (0 mmH ₂ O)		0 Pa (0 mmH ₂ O)		0 Pa (0 mmH ₂ O)	
Compressor	Type x Quantity		Inverter scroll hermetic compressor			Inverter scroll hermetic compressor		
	Starting method		Inverter		Inverter		Inverter	
	Motor output	kW	5.6		6.9		5.6	
	Case heater	kW	-		-		-	
External finish		Pre-coated galvanized steel sheets (+powder coating for -BS type) <MUNSELL 5Y 8/1 or similar>			Pre-coated galvanized steel sheets (+powder coating for -BS type) <MUNSELL 5Y 8/1 or similar>			
External dimension HxWxD		mm	1,710 (1,650 without legs) x 920 x 740		1,710 (1,650 without legs) x 920 x 740		1,710 (1,650 without legs) x 920 x 740	
		in.	67-3/8 (65 without legs) x 36-1/4 x 29-3/16		67-3/8 (65 without legs) x 36-1/4 x 29-3/16		67-3/8 (65 without legs) x 36-1/4 x 29-3/16	
Protection devices	High pressure protection		High pressure sensor, High pressure switch at 4.15 MPa (601 psi)			High pressure sensor, High pressure switch at 4.15 MPa (601 psi)		
	Inverter circuit (COMP./FAN)		Over-heat protection, Over-current protection			Over-heat protection, Over-current protection		
	Compressor		Over-heat protection		Over-heat protection		Over-heat protection	
	Fan motor		Over-current protection			Over-current protection		
Refrigerant	Type x original charge		R410A x 7.5 kg (17 lbs)		R410A x 7.5 kg (17 lbs)		R410A x 10.3 kg (23 lbs)	
Net weight		kg (lbs)	208 (459)		208 (459)		252 (556)	
Heat exchanger			Salt-resistant cross fin & aluminium tube			Salt-resistant cross fin & aluminium tube		
Pipe between unit and distributor	Liquid pipe	mm (in.)	9.52 (3/8) Brazed		9.52 (3/8) Brazed		12.7 (1/2) Brazed	
	Gas pipe	mm (in.)	22.2 (7/8) Brazed		22.2 (7/8) Brazed		28.58 (1-1/8) Brazed	
Optional parts			Outdoor Twinning kit: CMY-Y300VBK3 Joint: CMY-Y102SS/LS-G2, CMY-Y202/302S-G2 Header: CMY-Y104/108/1010-G			Outdoor Twinning kit: CMY-Y300VBK3 Joint: CMY-Y102SS/LS-G2, CMY-Y202/302S-G2 Header: CMY-Y104/108/1010-G		



Notes:

*1,*2 Nominal conditions

	Indoor	Outdoor	Pipe length	Level difference
Cooling	27°C DB/19°C WB (81°F DB/66°F WB)	35°C DB/24°C WB (95°F DB/75°F WB)	7.5m (24-9/16ft.)	0m (0ft.)
Heating	20°C DB(68°F DB)	7°C DB/6°C WB(45°F DB/43°F WB)	7.5m (24-9/16ft.)	0m (0ft.)

*3 External static pressure option is available (30Pa, 60Pa / 3.1mmH₂O, 6.1mmH₂O).

*Nominal condition *1,*2 are subject to JIS B8615-1.

*Due to continuing improvement, above specification may be subject to change without notice.

OUTDOOR UNIT Y Series - High COP PUHY-EP YSLM-A1(-BS)



► Specifications

Model			PUHY-EP750YSLM-A (-BS)			PUHY-EP800YSLM-A (-BS)						
Power source			3-phase 4-wire 380-400-415 V 50/60 Hz			3-phase 4-wire 380-400-415 V 50/60 Hz						
Cooling capacity (Nominal)	*1	kW	85.0			90.0						
	*1	BTU / h	290,000			307,100						
		Power input kW	21.85			23.43						
		Current input A	36.8-35.0-33.7			39.5-37.5-36.2						
		EER kW / kW	3.89			3.84						
Temp. range of cooling	Indoor	W.B.	15.0~24.0°C (59~75°F)			15.0~24.0°C (59~75°F)						
	Outdoor	D.B.	-5.0~52.0°C (23~126°F)			-5.0~52.0°C (23~126°F)						
Heating capacity (Nominal)	*2	kW	95.0			100.0						
	*2	BTU / h	324,100			341,200						
		Power input kW	23.92			25.18						
		Current input A	40.3-38.3-36.9			42.5-40.3-38.9						
		COP kW / kW	3.97			3.97						
Temp. range of heating	Indoor	D.B.	15.0~27.0°C (59~81°F)			15.0~27.0°C (59~81°F)						
	Outdoor	W.B.	-20.0~15.5°C (-4~60°F)			-20.0~15.5°C (-4~60°F)						
Indoor unit connectable	Total capacity		50~130% of outdoor unit capacity			50~130% of outdoor unit capacity						
	Model / Quantity		P15~P250/2~50			P15~P250/2~50						
Sound pressure level (measured in anechoic room)		dB <A>	64.5			65						
Sound power level (measured in anechoic room)		dB <A>	85.5			86.5						
Refrigerant piping diameter	Liquid pipe	mm (in.)	19.05 (3/4) Brazed			19.05 (3/4) Brazed						
	Gas pipe	mm (in.)	34.93 (1-3/8) Brazed			34.93 (1-3/8) Brazed						
Set Model												
Model			PUHY-EP200YLM-A (-BS)	PUHY-EP250YLM-A (-BS)	PUHY-EP300YLM-A (-BS)	PUHY-EP200YLM-A (-BS)	PUHY-EP300YLM-A (-BS)	PUHY-EP300YLM-A (-BS)				
FAN	Type x Quantity		Propeller fan x 1		Propeller fan x 1		Propeller fan x 1		Propeller fan x 1			
	Air flow rate	m ³ /min	175		175		200		175			
		L/s	2,917		2,917		3,333		2,917			
		cfm	6,179		6,179		7,062		6,179			
	Driving mechanism		Inverter-control, Direct-driven by motor				Inverter-control, Direct-driven by motor					
*3	Motor output	kW	0.92 x 1		0.92 x 1		0.92 x 1		0.92 x 1			
	External static press.		0 Pa (0 mmH ₂ O)		0 Pa (0 mmH ₂ O)		0 Pa (0 mmH ₂ O)		0 Pa (0 mmH ₂ O)			
	Type x Quantity		Inverter scroll hermetic compressor				Inverter scroll hermetic compressor					
Compressor	Starting method		Inverter		Inverter		Inverter		Inverter			
	Motor output		5.6		6.9		8.1		5.6			
	Case heater		-		-		-		-			
	Type x Quantity		Pre-coated galvanized steel sheets (+powder coating for -BS type) <MUNSELL 5Y 8/1 or similar>				Pre-coated galvanized steel sheets (+powder coating for -BS type) <MUNSELL 5Y 8/1 or similar>					
External dimension HxWxD	mm	1,710 (1,650 without legs) x 920 x 740		1,710 (1,650 without legs) x 920 x 740		1,710 (1,650 without legs) x 1,220 x 740		1,710 (1,650 without legs) x 920 x 740		1,710 (1,650 without legs) x 1,220 x 740		
		in.		67-3/8 (65 without legs) x 36-1/4 x 29-3/16		67-3/8 (65 without legs) x 36-1/4 x 29-3/16		67-3/8 (65 without legs) x 48-1/16 x 29-3/16		67-3/8 (65 without legs) x 36-1/4 x 29-3/16		
Protection devices	High pressure protection		High pressure sensor, High pressure switch at 4.15 MPa (601 psi)				High pressure sensor, High pressure switch at 4.15 MPa (601 psi)					
	Inverter circuit (COMP./FAN)		Over-heat protection, Over-current protection				Over-heat protection, Over-current protection					
	Compressor		Over-heat protection		Over-heat protection		Over-heat protection		Over-heat protection		Over-heat protection	
	Fan motor		Over-current protection				Over-current protection					
Refrigerant	Type x original charge		R410A x 7.5 kg (17 lbs)		R410A x 7.5 kg (17 lbs)		R410A x 10.3 kg (23 lbs)		R410A x 7.5 kg (17 lbs)		R410A x 10.3 kg (23 lbs)	
Net weight	kg (lbs)		208 (459)		208 (459)		252 (556)		208 (459)		252 (556)	
Heat exchanger			Salt-resistant cross fin & aluminium tube				Salt-resistant cross fin & aluminium tube					
Pipe between unit and distributor	Liquid pipe	mm (in.)	9.52 (3/8) Brazed		9.52 (3/8) Brazed		12.7 (1/2) Brazed		9.52 (3/8) Brazed		12.7 (1/2) Brazed	
	Gas pipe	mm (in.)	22.2 (7/8) Brazed		22.2 (7/8) Brazed		28.58 (1-1/8) Brazed		22.2 (7/8) Brazed		28.58 (1-1/8) Brazed	
Optional parts			Outdoor Twinning kit: CMY-Y300VBK3 Joint: CMY-Y102SS/LS-G2, CMY-Y202/302S-G2 Header: CMY-Y104/108/1010-G				Outdoor Twinning kit: CMY-Y300VBK3 Joint: CMY-Y102SS/LS-G2, CMY-Y202/302S-G2 Header: CMY-Y104/108/1010-G					



Notes:

*1,*2 Nominal conditions

	Indoor	Outdoor	Pipe length	Level difference
Cooling	27°C DB/19°C WB (81°F DB/66°F WB)	35°C DB/24°C WB (95°F DB/75°F WB)	7.5m (24-9/16ft.)	0m (0ft.)
Heating	20°C DB(68°F DB)	7°C DB/6°C WB(45°F DB/43°F WB)	7.5m (24-9/16ft.)	0m (0ft.)

*3 External static pressure option is available (30Pa, 60Pa / 3.1mmH₂O, 6.1mmH₂O).

*Nominal condition *1,*2 are subject to JIS B8615-1.

*Due to continuing improvement, above specification may be subject to change without notice.

OUTDOOR UNIT Y Series - High COP PUHY-EP YSLM-A1(-BS)



► Specifications

Model			PUHY-EP850YSLM-A (-BS)			PUHY-EP900YSLM-A (-BS)		
Power source			3-phase 4-wire 380-400-415 V 50/60 Hz			3-phase 4-wire 380-400-415 V 50/60 Hz		
Cooling capacity (Nominal)	*1	kW	96.0			101.0		
	*1	BTU / h	327,600			344,600		
		Power input kW	25.53			27.22		
		Current input A	43.0-40.9-39.4			45.9-43.6-42.0		
	EER	kW / kW	3.76			3.71		
Temp. range of cooling	Indoor	W.B.	15.0~24.0°C (59~75°F)			15.0~24.0°C (59~75°F)		
	Outdoor	D.B.	-5.0~52.0°C (23~126°F)			-5.0~52.0°C (23~126°F)		
Heating capacity (Nominal)	*2	kW	108.0			113.0		
	*2	BTU / h	368,500			385,600		
		Power input kW	27.76			29.04		
		Current input A	46.8-44.5-42.9			49.0-46.5-44.8		
	COP	kW / kW	3.89			3.89		
Temp. range of heating	Indoor	D.B.	15.0~27.0°C (59~81°F)			15.0~27.0°C (59~81°F)		
	Outdoor	W.B.	-20.0~15.5°C (-4~60°F)			-20.0~15.5°C (-4~60°F)		
Indoor unit connectable	Total capacity		50~130% of outdoor unit capacity			50~130% of outdoor unit capacity		
	Model / Quantity		P15~P250/2~50			P15~P250/2~50		
Sound pressure level (measured in anechoic room)	dB <A>		65.5			66		
Sound power level (measured in anechoic room)	dB <A>		86.5			87		
Refrigerant piping diameter	Liquid pipe mm (in.)		19.05 (3/4) Brazed			19.05 (3/4) Brazed		
	Gas pipe mm (in.)		41.28 (1-5/8) Brazed			41.28 (1-5/8) Brazed		
Set Model								
Model			PUHY-EP250YLM-A (-BS)	PUHY-EP300YLM-A (-BS)	PUHY-EP300YLM-A (-BS)	PUHY-EP300YLM-A (-BS)	PUHY-EP300YLM-A (-BS)	PUHY-EP300YLM-A (-BS)
FAN	Type x Quantity		Propeller fan x 1		Propeller fan x 1		Propeller fan x 1	
	Air flow rate	m ³ /min	175		200		200	
		L/s	2,917		3,333		3,333	
		cfm	6,179		7,062		7,062	
	Driving mechanism		Inverter-control, Direct-driven by motor					
	Motor output	kW	0.92 x 1		0.92 x 1		0.92 x 1	
*3	External static press.	0 Pa (0 mmH ₂ O)		0 Pa (0 mmH ₂ O)		0 Pa (0 mmH ₂ O)		
Compressor	Type x Quantity		Inverter scroll hermetic compressor			Inverter scroll hermetic compressor		
	Starting method		Inverter		Inverter		Inverter	
	Motor output	kW	6.9		8.1		8.1	
	Case heater	kW	-		-		-	
External finish			Pre-coated galvanized steel sheets (+powder coating for -BS type) <MUNSELL 5Y 8/1 or similar>			Pre-coated galvanized steel sheets (+powder coating for -BS type) <MUNSELL 5Y 8/1 or similar>		
External dimension HxWxD	mm		1,710 (1,650 without legs) x 920 x 740		1,710 (1,650 without legs) x 1,220 x 740		1,710 (1,650 without legs) x 1,220 x 740	
	in.		67-3/8 (65 without legs) x 36-1/4 x 29-3/16		67-3/8 (65 without legs) x 48-1/16 x 29-3/16		67-3/8 (65 without legs) x 48-1/16 x 29-3/16	
Protection devices	High pressure protection		High pressure sensor, High pressure switch at 4.15 MPa (601 psi)			High pressure sensor, High pressure switch at 4.15 MPa (601 psi)		
	Inverter circuit (COMP./FAN)		Over-heat protection, Over-current protection			Over-heat protection, Over-current protection		
	Compressor		Over-heat protection		Over-heat protection		Over-heat protection	
	Fan motor		Over-current protection			Over-current protection		
Refrigerant	Type x original charge	R410A x 7.5 kg (17 lbs)		R410A x 10.3 kg (23 lbs)		R410A x 10.3 kg (23 lbs)		
Net weight	kg (lbs)	208 (459)		252 (556)		252 (556)		
Heat exchanger			Salt-resistant cross fin & aluminium tube			Salt-resistant cross fin & aluminium tube		
Pipe between unit and distributor	Liquid pipe mm (in.)		9.52 (3/8) Brazed		12.7 (1/2) Brazed		12.7 (1/2) Brazed	
	Gas pipe mm (in.)		22.2 (7/8) Brazed		28.58 (1-1/8) Brazed		28.58 (1-1/8) Brazed	
Optional parts			Outdoor Twinning kit: CMY-Y300VBK3 Joint: CMY-Y102SS/LS-G2, CMY-Y202/302S-G2 Header: CMY-Y104/108/1010-G			Outdoor Twinning kit: CMY-Y300VBK3 Joint: CMY-Y102SS/LS-G2, CMY-Y202/302S-G2 Header: CMY-Y104/108/1010-G		



Notes:

*1,*2 Nominal conditions

	Indoor	Outdoor	Pipe length	Level difference
Cooling	27°C DB/19°C WB (81°F DB/66°F WB)	35°C DB/24°C WB (95°F DB/75°F WB)	7.5m (24-9/16ft.)	0m (0ft.)
Heating	20°C DB(68°F DB)	7°C DB/6°C WB(45°F DB/43°F WB)	7.5m (24-9/16ft.)	0m (0ft.)

*3 External static pressure option is available (30Pa, 60Pa / 3.1mmH₂O, 6.1mmH₂O).

*Nominal condition *1,*2 are subject to JIS B8615-1.

*Due to continuing improvement, above specification may be subject to change without notice.

OUTDOOR UNIT Y Series - High COP PUHY-EP YSLM-A1(-BS)



► Specifications

Model			PUHY-EP950YSLM-A (-BS)			PUHY-EP1000YSLM-A (-BS)			
Power source			3-phase 4-wire 380-400-415 V 50/60 Hz			3-phase 4-wire 380-400-415 V 50/60 Hz			
Cooling capacity (Nominal)	*1	kW	108.0			113.0			
	*1	BTU / h	368,500			385,600			
		Power input kW	30.33			31.04			
		Current input A	51.2-48.6-46.8			52.4-49.7-47.9			
	EER	kW / kW	3.56			3.64			
Temp. range of cooling	Indoor	W.B.	15.0~24.0°C (59~75°F)			15.0~24.0°C (59~75°F)			
	Outdoor	D.B.	-5.0~52.0°C (23~126°F)			-5.0~52.0°C (23~126°F)			
Heating capacity (Nominal)	*2	kW	119.5			127.0			
	*2	BTU / h	407,700			433,300			
		Power input kW	32.03			33.50			
		Current input A	54.0-51.3-49.5			56.5-53.7-51.7			
	COP	kW / kW	3.73			3.79			
Temp. range of heating	Indoor	D.B.	15.0~27.0°C (59~81°F)			15.0~27.0°C (59~81°F)			
	Outdoor	W.B.	-20.0~15.5°C (-4~60°F)			-20.0~15.5°C (-4~60°F)			
Indoor unit connectable	Total capacity		50~130% of outdoor unit capacity			50~130% of outdoor unit capacity			
	Model / Quantity		P15-P250/2~50			P15-P250/2~50			
Sound pressure level (measured in anechoic room)		dB <A>	66			66.5			
Sound power level (measured in anechoic room)		dB <A>	87			87			
Refrigerant piping diameter	Liquid pipe	mm (in.)	19.05 (3/4) Brazed			19.05 (3/4) Brazed			
	Gas pipe	mm (in.)	41.28 (1-5/8) Brazed			41.28 (1-5/8) Brazed			
Set Model									
Model			PUHY-EP300YLM-A (-BS)	PUHY-EP300YLM-A (-BS)	PUHY-EP350YLM-A (-BS)	PUHY-EP300YLM-A (-BS)	PUHY-EP300YLM-A (-BS)	PUHY-EP400YLM-A (-BS)	
FAN	Type x Quantity		Propeller fan x 1	Propeller fan x 1	Propeller fan x 1	Propeller fan x 1	Propeller fan x 1	Propeller fan x 2	
	Air flow rate	m ³ /min	200	200	200	200	200	320	
		L/s	3,333	3,333	3,333	3,333	3,333	5,333	
		cfm	7,062	7,062	7,062	7,062	7,062	11,299	
	Driving mechanism		Inverter-control, Direct-driven by motor						
Motor output	kW	0.92 x 1	0.92 x 1	0.92 x 1	0.92 x 1	0.92 x 1	0.92 x 2		
*3	External static press.		0 Pa (0 mmH ₂ O)	0 Pa (0 mmH ₂ O)	0 Pa (0 mmH ₂ O)	0 Pa (0 mmH ₂ O)	0 Pa (0 mmH ₂ O)	0 Pa (0 mmH ₂ O)	
Compressor	Type x Quantity		Inverter scroll hermetic compressor			Inverter scroll hermetic compressor			
	Starting method		Inverter	Inverter	Inverter	Inverter	Inverter	Inverter	
	Motor output		kW	8.1	8.1	10.5	8.1	8.1	10.9
	Case heater		kW	-	-	-	-	-	-
External finish			Pre-coated galvanized steel sheets (+powder coating for -BS type) <MUNSELL 5Y 8/1 or similar>			Pre-coated galvanized steel sheets (+powder coating for -BS type) <MUNSELL 5Y 8/1 or similar>			
External dimension HxWxD	mm		1,710 (1,650 without legs) x 1,220 x 740	1,710 (1,650 without legs) x 1,220 x 740	1,710 (1,650 without legs) x 1,220 x 740	1,710 (1,650 without legs) x 1,220 x 740	1,710 (1,650 without legs) x 1,220 x 740	1,710 (1,650 without legs) x 1,750 x 740	
	in.		67-3/8 (65 without legs) x 48-1/16 x 29-3/16	67-3/8 (65 without legs) x 48-1/16 x 29-3/16	67-3/8 (65 without legs) x 48-1/16 x 29-3/16	67-3/8 (65 without legs) x 48-1/16 x 29-3/16	67-3/8 (65 without legs) x 48-1/16 x 29-3/16	67-3/8 (65 without legs) x 68-15/16 x 29-3/16	
Protection devices	High pressure protection		High pressure sensor, High pressure switch at 4.15 MPa (601 psi)			High pressure sensor, High pressure switch at 4.15 MPa (601 psi)			
	Inverter circuit (COMP./FAN)		Over-heat protection, Over-current protection			Over-heat protection, Over-current protection			
	Compressor		Over-heat protection			Over-heat protection			
Fan motor		Over-current protection			Over-current protection				
Refrigerant	Type x original charge		R410A x 10.3 kg (23 lbs)	R410A x 10.3 kg (23 lbs)	R410A x 10.3 kg (23 lbs)	R410A x 10.3 kg (23 lbs)	R410A x 10.3 kg (23 lbs)	R410A x 11.8 kg (27 lbs)	
Net weight	kg (lbs)		252 (556)	252 (556)	252 (556)	252 (556)	252 (556)	318 (702)	
Heat exchanger			Salt-resistant cross fin & aluminium tube			Salt-resistant cross fin & aluminium tube			
Pipe between unit and distributor	Liquid pipe	mm (in.)	12.7 (1/2) Brazed	12.7 (1/2) Brazed	12.7 (1/2) Brazed	12.7 (1/2) Brazed	12.7 (1/2) Brazed	15.88 (5/8) Brazed	
	Gas pipe	mm (in.)	28.58 (1-1/8) Brazed	28.58 (1-1/8) Brazed	28.58 (1-1/8) Brazed	28.58 (1-1/8) Brazed	28.58 (1-1/8) Brazed	28.58 (1-1/8) Brazed	
Optional parts			Outdoor Twinning kit: CMY-Y300VBK3 Joint: CMY-Y102SS/LS-G2, CMY-Y202/302S-G2 Header: CMY-Y104/108/1010-G			Outdoor Twinning kit: CMY-Y300VBK3 Joint: CMY-Y102SS/LS-G2, CMY-Y202/302S-G2 Header: CMY-Y104/108/1010-G			



Notes:

*1,*2 Nominal conditions

	Indoor	Outdoor	Pipe length	Level difference
Cooling	27°C DB/19°C WB (81°F DB/66°F WB)	35°C DB/24°C WB (95°F DB/75°F WB)	7.5m (24-9/16ft.)	0m (0ft.)
Heating	20°C DB/68°F DB)	7°C DB/6°C WB(45°F DB/43°F WB)	7.5m (24-9/16ft.)	0m (0ft.)

*3 External static pressure option is available (30Pa, 60Pa / 3.1mmH₂O, 6.1mmH₂O).

*Nominal condition *1,*2 are subject to JIS B8615-1.

*Due to continuing improvement, above specification may be subject to change without notice.

OUTDOOR UNIT

Y Series - High COP

PUHY-EP YSLM-A1(-BS)



► Specifications

Model		PUHY-EP1050YSLM-A (-BS)			PUHY-EP1100YSLM-A (-BS)			
Power source		3-phase 4-wire 380-400-415 V 50/60 Hz			3-phase 4-wire 380-400-415 V 50/60 Hz			
Cooling capacity (Nominal)	*1 kW	118.0			124.0			
	*1 BTU / h	402,600			423,100			
	Power input kW	34.40			38.15			
	Current input A	58.0-55.1-53.1			64.4-61.1-58.9			
EER	kW / kW	3.43			3.25			
Temp. range of cooling	Indoor W.B.	15.0~24.0°C (59~75°F)			15.0~24.0°C (59~75°F)			
	Outdoor D.B.	-5.0~52.0°C (23~126°F)			-5.0~52.0°C (23~126°F)			
Heating capacity (Nominal)	*2 kW	132.0			140.0			
	*2 BTU / h	450,400			477,700			
	Power input kW	36.87			41.17			
	Current input A	62.2-59.1-56.9			69.5-66.0-63.6			
COP	kW / kW	3.58			3.40			
Temp. range of heating	Indoor D.B.	15.0~27.0°C (59~81°F)			15.0~27.0°C (59~81°F)			
	Outdoor W.B.	-20.0~15.5°C (-4~60°F)			-20.0~15.5°C (-4~60°F)			
Indoor unit connectable	Total capacity	50~130% of outdoor unit capacity			50~130% of outdoor unit capacity			
	Model / Quantity	P15-P250/3~50			P15-P250/3~50			
Sound pressure level (measured in anechoic room)	dB <A>	66.5			66.5			
Sound power level (measured in anechoic room)	dB <A>	87.5			87.5			
Refrigerant piping diameter	Liquid pipe mm (in.)	19.05 (3/4) Brazed			19.05 (3/4) Brazed			
	Gas pipe mm (in.)	41.28 (1-5/8) Brazed			41.28 (1-5/8) Brazed			
Set Model								
Model		PUHY-EP300YLM-A (-BS)	PUHY-EP350YLM-A (-BS)	PUHY-EP400YLM-A (-BS)	PUHY-EP350YLM-A (-BS)	PUHY-EP350YLM-A (-BS)	PUHY-EP400YLM-A (-BS)	
FAN	Type x Quantity	Propeller fan x 1		Propeller fan x 2	Propeller fan x 1		Propeller fan x 2	
	Air flow rate	m ³ /min	200		320	200		320
		L/s	3,333		5,333	3,333		5,333
		cfm	7,062		11,299	7,062		11,299
	Driving mechanism	Inverter-control, Direct-driven by motor						
Motor output kW	0.92 x 1	0.92 x 1	0.92 x 2	0.92 x 1	0.92 x 1	0.92 x 2		
*3 External static press.	0 Pa (0 mmH ₂ O)							
Compressor	Type x Quantity	Inverter scroll hermetic compressor						
	Starting method	Inverter		Inverter	Inverter		Inverter	
	Motor output kW	8.1		10.5	10.5		10.9	
	Case heater kW	-						
External finish	Pre-coated galvanized steel sheets (+powder coating for -BS type) <MUNSELL 5Y 8/1 or similar>				Pre-coated galvanized steel sheets (+powder coating for -BS type) <MUNSELL 5Y 8/1 or similar>			
External dimension HxWxD	mm	1,710 (1,650 without legs) x 1,220 x 740		1,710 (1,650 without legs) x 1,750 x 740	1,710 (1,650 without legs) x 1,220 x 740		1,710 (1,650 without legs) x 1,750 x 740	
	in.	67-3/8 (65 without legs) x 48-1/16 x 29-3/16		67-3/8 (65 without legs) x 68-15/16 x 29-3/16	67-3/8 (65 without legs) x 48-1/16 x 29-3/16		67-3/8 (65 without legs) x 68-15/16 x 29-3/16	
Protection devices	High pressure protection	High pressure sensor, High pressure switch at 4.15 MPa (601 psi)				High pressure sensor, High pressure switch at 4.15 MPa (601 psi)		
	Inverter circuit (COMP./FAN)	Over-heat protection, Over-current protection						
	Compressor	Over-heat protection		Over-heat protection	Over-heat protection		Over-heat protection	
Refrigerant	Type x original charge	R410A x 10.3 kg (23 lbs)		R410A x 11.8 kg (27 lbs)	R410A x 10.3 kg (23 lbs)		R410A x 11.8 kg (27 lbs)	
	Net weight	252 (556)		318 (702)	252 (556)		318 (702)	
Heat exchanger	Salt-resistant cross fin & aluminium tube							
Pipe between unit and distributor	Liquid pipe mm (in.)	12.7 (1/2) Brazed		15.88 (5/8) Brazed	12.7 (1/2) Brazed		15.88 (5/8) Brazed	
	Gas pipe mm (in.)	28.58 (1-1/8) Brazed		28.58 (1-1/8) Brazed	28.58 (1-1/8) Brazed		28.58 (1-1/8) Brazed	
Optional parts	Outdoor Twinning kit: CMY-Y300VBK3 Joint: CMY-Y102SS/LS-G2, CMY-Y202/302S-G2 Header: CMY-Y104/108/1010-G				Outdoor Twinning kit: CMY-Y300VBK3 Joint: CMY-Y102SS/LS-G2, CMY-Y202/302S-G2 Header: CMY-Y104/108/1010-G			



Notes:

*1,*2 Nominal conditions

	Indoor	Outdoor	Pipe length	Level difference
Cooling	27°C DB/19°C WB (81°F DB/66°F WB)	35°C DB/24°C WB (95°F DB/75°F WB)	7.5m (24-9/16ft.)	0m (0ft.)
Heating	20°C DB/68°F DB)	7°C DB/6°C WB(45°F DB/43°F WB)	7.5m (24-9/16ft.)	0m (0ft.)

*3 External static pressure option is available (30Pa, 60Pa / 3.1mmH₂O, 6.1mmH₂O).

*Nominal condition *1,*2 are subject to JIS B8615-1.

*Due to continuing improvement, above specification may be subject to change without notice.



Outdoor Unit

OUTDOOR UNIT Y Series - High COP PUHY-EP YSLM-A1 (-BS)



► Specifications

Model			PUHY-EP1150YSLM-A (-BS)			PUHY-EP1200YSLM-A (-BS)			
Power source			3-phase 4-wire 380-400-415 V 50/60 Hz			3-phase 4-wire 380-400-415 V 50/60 Hz			
Cooling capacity (Nominal)	*1	kW	130.0			136.0			
	*1	BTU / h	443,600			464,000			
		Power input kW	41.53			42.76			
		Current input A	70.1-66.6-64.1			72.1-68.5-66.0			
	EER	kW / kW	3.13			3.18			
Temp. range of cooling	Indoor	W.B.	15.0~24.0°C (59~75°F)			15.0~24.0°C (59~75°F)			
	Outdoor	D.B.	-5.0~52.0°C (23~126°F)			-5.0~52.0°C (23~126°F)			
Heating capacity (Nominal)	*2	kW	145.0			150.0			
	*2	BTU / h	494,700			511,800			
		Power input kW	44.47			45.45			
		Current input A	75.0-71.3-68.7			76.7-72.8-70.2			
	COP	kW / kW	3.26			3.30			
Temp. range of heating	Indoor	D.B.	15.0~27.0°C (59~81°F)			15.0~27.0°C (59~81°F)			
	Outdoor	W.B.	-20.0~15.5°C (-4~60°F)			-20.0~15.5°C (-4~60°F)			
Indoor unit connectable	Total capacity		50~130% of outdoor unit capacity			50~130% of outdoor unit capacity			
	Model / Quantity		P15-P250/3~50			P15-P250/3~50			
Sound pressure level (measured in anechoic room)		dB <A>	66.5			67			
Sound power level (measured in anechoic room)		dB <A>	87.5			87.5			
Refrigerant piping diameter	Liquid pipe	mm (in.)	19.05 (3/4) Brazed			19.05 (3/4) Brazed			
	Gas pipe	mm (in.)	41.28 (1-5/8) Brazed			41.28 (1-5/8) Brazed			
Set Model									
Model			PUHY-EP350YLM-A (-BS)	PUHY-EP350YLM-A (-BS)	PUHY-EP450YLM-A (-BS)	PUHY-EP350YLM-A (-BS)	PUHY-EP400YLM-A (-BS)	PUHY-EP450YLM-A (-BS)	
FAN	Type x Quantity		Propeller fan x 1	Propeller fan x 1	Propeller fan x 2	Propeller fan x 1	Propeller fan x 2	Propeller fan x 2	
	Air flow rate	m ³ /min	200	200	370	200	320	370	
		L/s	3,333	3,333	6,167	3,333	5,333	6,167	
		cfm	7,062	7,062	13,065	7,062	11,299	13,065	
	Driving mechanism		Inverter-control, Direct-driven by motor						
Motor output	kW	0.92 x 1	0.92 x 1	0.92 x 2	0.92 x 1	0.92 x 2	0.92 x 2		
*3	External static press.		0 Pa (0 mmH ₂ O)	0 Pa (0 mmH ₂ O)	0 Pa (0 mmH ₂ O)	0 Pa (0 mmH ₂ O)	0 Pa (0 mmH ₂ O)	0 Pa (0 mmH ₂ O)	
Compressor	Type x Quantity		Inverter scroll hermetic compressor			Inverter scroll hermetic compressor			
	Starting method		Inverter	Inverter	Inverter	Inverter	Inverter	Inverter	
	Motor output		kW	10.5	10.5	12.4	10.5	10.9	12.4
	Case heater		kW	-	-	-	-	-	-
External finish			Pre-coated galvanized steel sheets (+powder coating for -BS type) <MUNSELL 5Y 8/1 or similar>			Pre-coated galvanized steel sheets (+powder coating for -BS type) <MUNSELL 5Y 8/1 or similar>			
External dimension HxWxD	mm		1,710 (1,650 without legs) x 1,220 x 740	1,710 (1,650 without legs) x 1,220 x 740	1,710 (1,650 without legs) x 1,750 x 740	1,710 (1,650 without legs) x 1,220 x 740	1,710 (1,650 without legs) x 1,750 x 740	1,710 (1,650 without legs) x 1,750 x 740	
	in.		67-3/8 (65 without legs) x 48-1/16 x 29-3/16	67-3/8 (65 without legs) x 48-1/16 x 29-3/16	67-3/8 (65 without legs) x 68-15/16 x 29-3/16	67-3/8 (65 without legs) x 48-1/16 x 29-3/16	67-3/8 (65 without legs) x 68-15/16 x 29-3/16	67-3/8 (65 without legs) x 68-15/16 x 29-3/16	
Protection devices	High pressure protection		High pressure sensor, High pressure switch at 4.15 MPa (601 psi)			High pressure sensor, High pressure switch at 4.15 MPa (601 psi)			
	Inverter circuit (COMP./FAN)		Over-heat protection, Over-current protection			Over-heat protection, Over-current protection			
	Compressor		Over-heat protection	Over-heat protection	Over-heat protection	Over-heat protection	Over-heat protection	Over-heat protection	
Fan motor		Over-current protection	Over-current protection	Over-current protection	Over-current protection	Over-current protection	Over-current protection		
Refrigerant	Type x original charge		R410A x 10.3 kg (23 lbs)	R410A x 10.3 kg (23 lbs)	R410A x 11.8 kg (27 lbs)	R410A x 10.3 kg (23 lbs)	R410A x 11.8 kg (27 lbs)	R410A x 11.8 kg (27 lbs)	
Net weight	kg (lbs)		252 (556)	252 (556)	318 (702)	252 (556)	318 (702)	318 (702)	
Heat exchanger			Salt-resistant cross fin & aluminium tube			Salt-resistant cross fin & aluminium tube			
Pipe between unit and distributor	Liquid pipe	mm (in.)	12.7 (1/2) Brazed	12.7 (1/2) Brazed	15.88 (5/8) Brazed	12.7 (1/2) Brazed	15.88 (5/8) Brazed	15.88 (5/8) Brazed	
	Gas pipe	mm (in.)	28.58 (1-1/8) Brazed	28.58 (1-1/8) Brazed	28.58 (1-1/8) Brazed	28.58 (1-1/8) Brazed	28.58 (1-1/8) Brazed	28.58 (1-1/8) Brazed	
Optional parts			Outdoor Twinning kit: CMY-Y300VBK3 Joint: CMY-Y102SS/LS-G2, CMY-Y202/302S-G2 Header: CMY-Y104/108/1010-G			Outdoor Twinning kit: CMY-Y300VBK3 Joint: CMY-Y102SS/LS-G2, CMY-Y202/302S-G2 Header: CMY-Y104/108/1010-G			



Notes:

*1,*2 Nominal conditions

	Indoor	Outdoor	Pipe length	Level difference
Cooling	27°C DB/19°C WB (81°F DB/66°F WB)	35°C DB/24°C WB (95°F DB/75°F WB)	7.5m (24-9/16ft.)	0m (0ft.)
Heating	20°C DB(68°F DB)	7°C DB/6°C WB(45°F DB/43°F WB)	7.5m (24-9/16ft.)	0m (0ft.)

*3 External static pressure option is available (30Pa, 60Pa / 3.1mmH₂O, 6.1mmH₂O).

*Nominal condition *1,*2 are subject to JIS B8615-1.

*Due to continuing improvement, above specification may be subject to change without notice.

OUTDOOR UNIT Y Series - High COP PUHY-EP YSLM-A1 (-BS)



► Specifications

Model			PUHY-EP1250YSLM-A (-BS)			PUHY-EP1300YSLM-A (-BS)			
Power source			3-phase 4-wire 380-400-415 V 50/60 Hz			3-phase 4-wire 380-400-415 V 50/60 Hz			
Cooling capacity (Nominal)	*1	kW	140.0			146.0			
	*1	BTU / h	477,700			498,200			
		Power input kW	45.90			46.94			
		Current input A	77.4-73.6-70.9			79.2-75.2-72.5			
	EER	kW / kW	3.05			3.11			
Temp. range of cooling	Indoor	W.B.	15.0~24.0°C (59~75°F)			15.0~24.0°C (59~75°F)			
	Outdoor	D.B.	-5.0~52.0°C (23~126°F)			-5.0~52.0°C (23~126°F)			
Heating capacity (Nominal)	*2	kW	156.5			163.0			
	*2	BTU / h	534,000			556,200			
		Power input kW	49.36			50.62			
		Current input A	83.3-79.1-76.2			85.4-81.1-78.2			
	COP	kW / kW	3.17			3.22			
Temp. range of heating	Indoor	D.B.	15.0~27.0°C (59~81°F)			15.0~27.0°C (59~81°F)			
	Outdoor	W.B.	-20.0~15.5°C (-4~60°F)			-20.0~15.5°C (-4~60°F)			
Indoor unit connectable	Total capacity		50~130% of outdoor unit capacity			50~130% of outdoor unit capacity			
	Model / Quantity		P15-P250/3~50			P15-P250/3~50			
Sound pressure level (measured in anechoic room)		dB <A>	67.5			68			
Sound power level (measured in anechoic room)		dB <A>	88			88			
Refrigerant piping diameter	Liquid pipe	mm (in.)	19.05 (3/4) Brazed			19.05 (3/4) Brazed			
	Gas pipe	mm (in.)	41.28 (1-5/8) Brazed			41.28 (1-5/8) Brazed			
Set Model									
Model			PUHY-EP350YLM-A (-BS)	PUHY-EP450YLM-A (-BS)	PUHY-EP450YLM-A (-BS)	PUHY-EP400YLM-A (-BS)	PUHY-EP450YLM-A (-BS)	PUHY-EP450YLM-A (-BS)	
FAN	Type x Quantity		Propeller fan x 1	Propeller fan x 2	Propeller fan x 2	Propeller fan x 2	Propeller fan x 2	Propeller fan x 2	
	Air flow rate	m ³ /min	200	370	370	320	370	370	
		L/s	3,333	6,167	6,167	5,333	6,167	6,167	
		cfm	7,062	13,065	13,065	11,299	13,065	13,065	
	Driving mechanism		Inverter-control, Direct-driven by motor						
Motor output	kW	0.92 x 1	0.92 x 2	0.92 x 2	0.92 x 2	0.92 x 2	0.92 x 2		
*3	External static press.		0 Pa (0 mmH ₂ O)	0 Pa (0 mmH ₂ O)	0 Pa (0 mmH ₂ O)	0 Pa (0 mmH ₂ O)	0 Pa (0 mmH ₂ O)	0 Pa (0 mmH ₂ O)	
Compressor	Type x Quantity		Inverter scroll hermetic compressor						
	Starting method		Inverter	Inverter	Inverter	Inverter	Inverter	Inverter	
	Motor output		kW	10.5	12.4	12.4	10.9	12.4	12.4
	Case heater		kW	—	—	—	—	—	—
External finish			Pre-coated galvanized steel sheets (+powder coating for -BS type) <MUNSELL 5Y 8/1 or similar>			Pre-coated galvanized steel sheets (+powder coating for -BS type) <MUNSELL 5Y 8/1 or similar>			
External dimension HxWxD	mm		1,710 (1,650 without legs) x 1,220 x 740	1,710 (1,650 without legs) x 1,750 x 740	1,710 (1,650 without legs) x 1,750 x 740	1,710 (1,650 without legs) x 1,750 x 740	1,710 (1,650 without legs) x 1,750 x 740	1,710 (1,650 without legs) x 1,750 x 740	
	in.		67-3/8 (65 without legs) x 48-1/16 x 29-3/16	67-3/8 (65 without legs) x 68-15/16 x 29-3/16	67-3/8 (65 without legs) x 68-15/16 x 29-3/16	67-3/8 (65 without legs) x 68-15/16 x 29-3/16	67-3/8 (65 without legs) x 68-15/16 x 29-3/16	67-3/8 (65 without legs) x 68-15/16 x 29-3/16	
Protection devices	High pressure protection		High pressure sensor, High pressure switch at 4.15 MPa (601 psi)			High pressure sensor, High pressure switch at 4.15 MPa (601 psi)			
	Inverter circuit (COMP./FAN)		Over-heat protection, Over-current protection						
	Compressor		Over-heat protection Over-heat protection Over-heat protection Over-heat protection Over-heat protection Over-heat protection						
Fan motor		Over-current protection Over-current protection Over-current protection Over-current protection Over-current protection Over-current protection							
Refrigerant	Type x original charge		R410A x 10.3 kg (23 lbs)	R410A x 11.8 kg (27 lbs)	R410A x 11.8 kg (27 lbs)	R410A x 11.8 kg (27 lbs)	R410A x 11.8 kg (27 lbs)	R410A x 11.8 kg (27 lbs)	
Net weight	kg (lbs)		252 (556)	318 (702)	318 (702)	318 (702)	318 (702)	318 (702)	
Heat exchanger			Salt-resistant cross fin & aluminium tube						
Pipe between unit and distributor	Liquid pipe	mm (in.)	12.7 (1/2) Brazed	15.88 (5/8) Brazed	15.88 (5/8) Brazed	15.88 (5/8) Brazed	15.88 (5/8) Brazed	15.88 (5/8) Brazed	
	Gas pipe	mm (in.)	28.58 (1-1/8) Brazed	28.58 (1-1/8) Brazed	28.58 (1-1/8) Brazed	28.58 (1-1/8) Brazed	28.58 (1-1/8) Brazed	28.58 (1-1/8) Brazed	
Optional parts			Outdoor Twinning kit: CMY-Y300VBK3 Joint: CMY-Y102SS/LS-G2, CMY-Y202/302S-G2 Header: CMY-Y104/108/1010-G			Outdoor Twinning kit: CMY-Y300VBK3 Joint: CMY-Y102SS/LS-G2, CMY-Y202/302S-G2 Header: CMY-Y104/108/1010-G			



Notes:

*1,*2 Nominal conditions

	Indoor	Outdoor	Pipe length	Level difference
Cooling	27°C DB/19°C WB (81°F DB/66°F WB)	35°C DB/24°C WB (95°F DB/75°F WB)	7.5m (24-9/16ft.)	0m (0ft.)
Heating	20°C DB(68°F DB)	7°C DB/6°C WB(45°F DB/43°F WB)	7.5m (24-9/16ft.)	0m (0ft.)

*3 External static pressure option is available (30Pa, 60Pa / 3.1mmH₂O, 6.1mmH₂O).

*Nominal condition *1,*2 are subject to JIS B8615-1.

*Due to continuing improvement, above specification may be subject to change without notice.



Outdoor Unit

OUTDOOR UNIT Y Series - High COP PUHY-EP YSLM-A1(-BS)



► Specifications

Model		PUHY-EP1350YSLM-A (-BS)				
Power source		3-phase 4-wire 380-400-415 V 50/60 Hz				
Cooling capacity (Nominal)	*1 kW	150.0				
	*1 BTU / h	511,800				
	Power input kW	50.00				
	Current input A	84.4-80.1-77.2				
EER	3.00					
Temp. range of cooling	Indoor W.B.	15.0~24.0°C (59~75°F)				
	Outdoor D.B.	-5.0~52.0°C (23~126°F)				
Heating capacity (Nominal)	*2 kW	168.0				
	*2 BTU / h	573,200				
	Power input kW	54.36				
	Current input A	91.7-87.1-84.0				
COP	3.09					
Temp. range of heating	Indoor D.B.	15.0~27.0°C (59~81°F)				
	Outdoor W.B.	-20.0~15.5°C (-4~60°F)				
Indoor unit connectable	Total capacity	50~130% of outdoor unit capacity				
	Model / Quantity	P15-P250/3~50				
Sound pressure level (measured in anechoic room)	dB <A>	68				
Sound power level (measured in anechoic room)	dB <A>	88				
Refrigerant piping diameter	Liquid pipe mm (in.)	19.05 (3/4) Brazed				
	Gas pipe mm (in.)	41.28 (1-5/8) Brazed				
Set Model						
Model		PUHY-EP450YLM-A (-BS)		PUHY-EP450YLM-A (-BS)		
FAN	Type x Quantity	Propeller fan x 2		Propeller fan x 2		
	Air flow rate	m ³ /min	370		370	
		L/s	6,167		6,167	
		cfm	13,065		13,065	
	Driving mechanism	Inverter-control, Direct-driven by motor				
	Motor output kW	0.92 x 2		0.92 x 2		
*3 External static press.	0 Pa (0 mmH ₂ O)		0 Pa (0 mmH ₂ O)			
Compressor	Type x Quantity	Inverter scroll hermetic compressor				
	Starting method	Inverter		Inverter		
	Motor output kW	12.4		12.4		
	Case heater kW	-		-		
External finish	Pre-coated galvanized steel sheets (+powder coating for -BS type) <MUNSELL 5Y 8/1 or similar>					
External dimension HxWxD	mm	1,710 (1,650 without legs) x 1,750 x 740		1,710 (1,650 without legs) x 1,750 x 740		
	in.	67-3/8 (65 without legs) x 68-15/16 x 29-3/16		67-3/8 (65 without legs) x 68-15/16 x 29-3/16		
Protection devices	High pressure protection	High pressure sensor, High pressure switch at 4.15 MPa (601 psi)				
	Inverter circuit (COMP./FAN)	Over-heat protection, Over-current protection				
	Compressor	Over-heat protection		Over-heat protection		
	Fan motor	Over-current protection		Over-current protection		
Refrigerant	Type x original charge	R410A x 11.8 kg (27 lbs)		R410A x 11.8 kg (27 lbs)		
Net weight	kg (lbs)	318 (702)		318 (702)		
Heat exchanger	Salt-resistant cross fin & aluminium tube					
Pipe between unit and distributor	Liquid pipe mm (in.)	15.88 (5/8) Brazed		15.88 (5/8) Brazed		
	Gas pipe mm (in.)	28.58 (1-1/8) Brazed		28.58 (1-1/8) Brazed		
Optional parts	Outdoor Twinning kit: CMY-Y300VBK3 Joint: CMY-Y102SS/LS-G2, CMY-Y202/302S-G2 Header: CMY-Y104/108/1010-G					



Notes:

*1,*2 Nominal conditions

	Indoor	Outdoor	Pipe length	Level difference
Cooling	27°C DB/19°C WB (81°F DB/66°F WB)	35°C DB/24°C WB (95°F DB/75°F WB)	7.5m (24-9/16ft.)	0m (0ft.)
Heating	20°C DB(68°F DB)	7°C DB/6°C WB(45°F DB/43°F WB)	7.5m (24-9/16ft.)	0m (0ft.)

*3 External static pressure option is available (30Pa, 60Pa / 3.1mmH₂O, 6.1mmH₂O).

*Nominal condition *1,*2 are subject to JIS B8615-1.

*Due to continuing improvement, above specification may be subject to change without notice.

HEAT SOURCE UNIT WY (Heat Pump) Series PQHY-P YLM-A

NEW



► Specifications

Model		PQHY-P200YLM-A	PQHY-P250YLM-A	PQHY-P300YLM-A
Power source		3-phase 4-wire 380-400-415 V 50/60 Hz	3-phase 4-wire 380-400-415 V 50/60 Hz	3-phase 4-wire 380-400-415 V 50/60 Hz
Cooling capacity (Nominal)	*1 kW	22.4	28.0	33.5
	*1 kcal / h	20,000	25,000	30,000
	*1 BTU / h	76,400	95,500	114,300
	Power input kW	3.71	4.90	6.04
	Current input A	6.2-5.9-5.7	8.2-7.8-7.5	10.1-9.6-9.3
EER	kW / kW	6.03	5.71	5.54
Temp. range of cooling	Indoor W.B.	15.0~24.0°C (59~75°F)	15.0~24.0°C (59~75°F)	15.0~24.0°C (59~75°F)
	Circulating water °C	10.0~45.0°C (50~113°F)	10.0~45.0°C (50~113°F)	10.0~45.0°C (50~113°F)
Heating capacity (Nominal)	*2 kW	25.0	31.5	37.5
	*2 kcal / h	21,500	27,100	32,300
	*2 BTU / h	85,300	107,500	128,000
	Power input kW	3.97	5.08	6.25
	Current input A	6.7-6.3-6.1	8.5-8.1-7.8	10.5-10.0-9.6
COP	kW / kW	6.29	6.20	6.00
Temp. range of heating	Indoor D.B.	15.0~27.0°C (59~81°F)	15.0~27.0°C (59~81°F)	15.0~27.0°C (59~81°F)
	Circulating water °C	10.0~45.0°C (50~113°F)	10.0~45.0°C (50~113°F)	10.0~45.0°C (50~113°F)
Indoor unit connectable	Total capacity	50~130% of heat source unit capacity	50~130% of heat source unit capacity	50~130% of heat source unit capacity
	Model / Quantity	P15~P250/1~17	P15~P250/1~21	P15~P250/1~26
Sound pressure level (measured in anechoic room)	dB <A>	46	48	54
Refrigerant piping diameter	Liquid pipe mm (in.)	9.52 (3/8) Brazed	9.52 (3/8) Brazed (12.7 (1/2) Brazed, farthest length >= 90 m)	9.52 (3/8) Brazed (12.7 (1/2) Brazed, farthest length >= 40 m)
	Gas pipe mm (in.)	19.05 (3/4) Brazed	22.2 (7/8) Brazed	22.2 (7/8) Brazed
Circulating water	Water flow rate m ³ / h	5.76	5.76	5.76
	L/min	96	96	96
	cfm	3.4	3.4	3.4
	Pressure drop kPa	24	24	24
	Operating volume range m ³ / h	3.0 ~ 7.2	3.0 ~ 7.2	3.0 ~ 7.2
Compressor	Type	Inverter scroll hermetic compressor	Inverter scroll hermetic compressor	Inverter scroll hermetic compressor
	Starting method	Inverter	Inverter	Inverter
	Motor output kW	4.8	6.2	7.7
	Case heater kW	—	—	—
External finish		Galvanized steel sheets	Galvanized steel sheets	Galvanized steel sheets
External dimension HxWxD	mm	1,100 x 880 x 550	1,100 x 880 x 550	1,100 x 880 x 550
	in.	43-5/16 x 34-11/16 x 21-11/16	43-5/16 x 34-11/16 x 21-11/16	43-5/16 x 34-11/16 x 21-11/16
Protection devices	High pressure protection	High pressure sensor, High pressure switch at 4.15 MPa (601 psi)	High pressure sensor, High pressure switch at 4.15 MPa (601 psi)	High pressure sensor, High pressure switch at 4.15 MPa (601 psi)
	Inverter circuit (COMP.)	Over-heat protection, Over-current protection	Over-heat protection, Over-current protection	Over-heat protection, Over-current protection
	Compressor	Over-heat protection	Over-heat protection	Over-heat protection
Refrigerant	Type x original charge	R410A x 5.0 kg (12 lbs)	R410A x 5.0 kg (12 lbs)	R410A x 5.0 kg (12 lbs)
Net weight	kg (lbs)	174 (384)	174 (384)	174 (384)
Heat exchanger		plate type	plate type	plate type
	Water volume in plate L	5.0	5.0	5.0
	Water pressure Max. MPa	2.0	2.0	2.0
Optional parts		Joint: CMY-Y102SS/LS-G2 Header: CMY-Y104, 108, 1010-G	Joint: CMY-Y102SS/LS-G2 Header: CMY-Y104, 108, 1010-G	Joint: CMY-Y102SS/LS-G2 Header: CMY-Y104, 108, 1010-G

Notes:

*1,*2 Nominal conditions

	Indoor	Water temperature	Pipe length	Level difference
Cooling	27°C D.B./19°C W.B. (81°F D.B./66°F W.B.)	30°C (86°F)	7.5m (24-9/16ft.)	0m (0ft.)
Heating	20°C D.B. (68°F D.B.)	20°C (68°F)		

*The ambient temperature of the heat source unit needs to be kept below 40°C D.B.

*The ambient relative humidity of the heat source unit needs to be kept below 80%.

*The heat source unit should not be installed at outdoor.

*Be sure to mount a strainer (more than 50 meshes) at the water inlet piping of the unit.

*Be sure to provide interlocking for the unit operation and water circuit.

*Nominal condition *1,*2 are subject to JIS B8615-2.

*Due to continuing improvement, above specification may be subject to change without notice.

Outdoor Unit

HEAT SOURCE UNIT WY (Heat Pump) Series PQHY-P YLM-A

NEW



► Specifications

Model	PQHY-P350YLM-A		PQHY-P400YLM-A		PQHY-P450YLM-A		
Power source	3-phase 4-wire 380-400-415 V 50/60 Hz		3-phase 4-wire 380-400-415 V 50/60 Hz		3-phase 4-wire 380-400-415 V 50/60 Hz		
Cooling capacity (Nominal)	*1	kW	40.0	45.0	50.0		
		kcal / h	35,000	40,000	45,000		
	*1	BTU / h	136,500	153,500	170,600		
		Power input	kW	7.14	8.03	9.29	
	Current input	A	12.0-11.4-11.0	13.5-12.8-12.4	15.6-14.8-14.3		
EER	kW / kW	5.60	5.60	5.38			
Temp. range of cooling	Indoor	W.B.	15.0~24.0°C (59~75°F)	15.0~24.0°C (59~75°F)	15.0~24.0°C (59~75°F)		
	Circulating water	°C	10.0~45.0°C (50~113°F)	10.0~45.0°C (50~113°F)	10.0~45.0°C (50~113°F)		
Heating capacity (Nominal)	*2	kW	45.0	50.0	56.0		
		kcal / h	40,000	45,000	50,000		
	*2	BTU / h	153,500	170,600	191,100		
		Power input	kW	7.53	8.37	9.79	
	Current input	A	12.7-12.0-11.6	14.1-13.4-12.9	16.5-15.7-15.1		
COP	kW / kW	5.97	5.97	5.72			
Temp. range of heating	Indoor	D.B.	15.0~27.0°C (59~81°F)	15.0~27.0°C (59~81°F)	15.0~27.0°C (59~81°F)		
	Circulating water	°C	10.0~45.0°C (50~113°F)	10.0~45.0°C (50~113°F)	10.0~45.0°C (50~113°F)		
Indoor unit connectable	Total capacity	50~130% of heat source unit capacity		50~130% of heat source unit capacity		50~130% of heat source unit capacity	
	Model / Quantity	P15~P250/1~30		P15~P250/1~34		P15~P250/1~39	
Sound pressure level (measured in anechoic room)	Model / Quantity	52		52		54	
Refrigerant piping diameter	Liquid pipe	mm (in.)	12.7 (1/2) Brazed	15.88 (5/8) Brazed	15.88 (5/8) Brazed		
	Gas pipe	mm (in.)	28.58 (1-1/8) Brazed	28.58 (1-1/8) Brazed	28.58 (1-1/8) Brazed		
Circulating water	Water flow rate	m ³ / h	7.20	7.20	7.20		
		L/min	120	120	120		
		cfm	4.2	4.2	4.2		
	Pressure drop	kPa	44	44	44		
	Operating volume range	m ³ / h	4.5 ~ 11.6	4.5 ~ 11.6	4.5 ~ 11.6		
Compressor	Type	Inverter scroll hermetic compressor		Inverter scroll hermetic compressor		Inverter scroll hermetic compressor	
	Starting method	Inverter		Inverter		Inverter	
	Motor output	kW	9.5	10.7	11.6		
	Case heater	kW	—	—	—		
External finish	Galvanized steel sheets		Galvanized steel sheets		Galvanized steel sheets		
External dimension HxWxD	mm	1,450 x 880 x 550		1,450 x 880 x 550		1,450 x 880 x 550	
	in.	57-1/8 x 34-11/16 x 21-11/16		57-1/8 x 34-11/16 x 21-11/16		57-1/8 x 34-11/16 x 21-11/16	
Protection devices	High pressure protection	High pressure sensor, High pressure switch at 4.15 MPa (601 psi)		High pressure sensor, High pressure switch at 4.15 MPa (601 psi)		High pressure sensor, High pressure switch at 4.15 MPa (601 psi)	
	Inverter circuit (COMP.)	Over-heat protection, Over-current protection		Over-heat protection, Over-current protection		Over-heat protection, Over-current protection	
	Compressor	Over-heat protection		Over-heat protection		Over-heat protection	
Refrigerant	Type x original charge	R410A x 6.0 kg (14 lbs)		R410A x 6.0 kg (14 lbs)		R410A x 6.0 kg (14 lbs)	
Net weight	kg (lbs)	217 (479)		217 (479)		217 (479)	
Heat exchanger	plate type		plate type		plate type		
	Water volume in plate	L	5.0	5.0	5.0		
	Water pressure Max.	MPa	2.0	2.0	2.0		
Optional parts	Joint: CMY-Y102SS/LS-G2, CMY-Y202S-G2 Header: CMY-Y104, 108, 1010-G		Joint: CMY-Y102SS/LS-G2, CMY-Y202S-G2 Header: CMY-Y104, 108, 1010-G		Joint: CMY-Y102SS/LS-G2, CMY-Y202S-G2 Header: CMY-Y104, 108, 1010-G		

Notes:

*1,*2 Nominal conditions

	Indoor	Water temperature	Pipe length	Level difference
Cooling	27°C D.B./19°C W.B. (81°F D.B./66°F W.B.)	30°C (86°F)	7.5m (24-9/16ft.)	0m (0ft.)
Heating	20°C D.B. (68°F D.B.)	20°C (68°F)		

*The ambient temperature of the heat source unit needs to be kept below 40°C D.B.

*The ambient relative humidity of the heat source unit needs to be kept below 80%.

*The heat source unit should not be installed at outdoor.

*Be sure to mount a strainer (more than 50 meshes) at the water inlet piping of the unit.

*Be sure to provide interlocking for the unit operation and water circuit.

*Nominal condition *1,*2 are subject to JIS B8615-2.

*Due to continuing improvement, above specification may be subject to change without notice.

Outdoor Unit

HEAT SOURCE UNIT WY (Heat Pump) Series PQHY-P YLM-A

NEW



► Specifications

Model	PQHY-P500YLM-A		PQHY-P550YLM-A		PQHY-P600YLM-A			
Power source	3-phase 4-wire 380-400-415 V 50/60 Hz		3-phase 4-wire 380-400-415 V 50/60 Hz		3-phase 4-wire 380-400-415 V 50/60 Hz			
Cooling capacity (Nominal)	*1	kW	56.0		63.0			
		kcal / h	50,000		55,000			
	*1	BTU / h	191,100		215,000			
		Power input kW	11.17		12.54			
		Current input A	18.8-17.9-17.2		21.1-20.1-19.3			
	EER	kW / kW	5.01		5.02			
Temp. range of cooling	Indoor	W.B.	15.0~24.0°C (59~75°F)		15.0~24.0°C (59~75°F)			
	Circulating water	°C	10.0~45.0°C (50~113°F)		10.0~45.0°C (50~113°F)			
Heating capacity (Nominal)	*2	kW	63.0		69.0			
		kcal / h	55,000		60,000			
	*2	BTU / h	215,000		235,400			
		Power input kW	11.43		12.27			
		Current input A	19.2-18.3-17.6		20.7-19.6-18.9			
	COP	kW / kW	5.51		5.62			
Temp. range of heating	Indoor	D.B.	15.0~27.0°C (59~81°F)		15.0~27.0°C (59~81°F)			
	Circulating water	°C	10.0~45.0°C (50~113°F)		10.0~45.0°C (50~113°F)			
Indoor unit connectable	Total capacity	50~130% of heat source unit capacity		50~130% of heat source unit capacity		50~130% of heat source unit capacity		
	Model / Quantity	P15~P250/1~43		P15~P250/2~47		P15~P250/2~50		
Sound pressure level (measured in anechoic room)	dB <A>	54		56.5		56.5		
Refrigerant piping diameter	Liquid pipe	mm (in.)	15.88 (5/8) Brazed		15.88 (5/8) Brazed		15.88 (5/8) Brazed	
	Gas pipe	mm (in.)	28.58 (1-1/8) Brazed		28.58 (1-1/8) Brazed		28.58 (1-1/8) Brazed	
Circulating water	Water flow rate	m ³ / h	7.20		11.52		11.52	
		L/min	120		192		192	
		cfm	4.2		6.8		6.8	
	Pressure drop	kPa	44		45		45	
	Operating volume range	m ³ / h	4.5 ~ 11.6		6.0 ~ 14.4		6.0 ~ 14.4	
Compressor	Type	Inverter scroll hermetic compressor		Inverter scroll hermetic compressor		Inverter scroll hermetic compressor		
	Starting method	Inverter		Inverter		Inverter		
	Motor output	kW	13.0		15.0		16.1	
	Case heater	kW	-		0.045 (240 V)		0.045 (240 V)	
External finish	Galvanized steel sheets		Galvanized steel sheets		Galvanized steel sheets		Galvanized steel sheets	
External dimension HxWxD	mm	1,450 x 880 x 550		1,450 x 880 x 550		1,450 x 880 x 550		
	in.	57-1/8 x 34-11/16 x 21-11/16		57-1/8 x 34-11/16 x 21-11/16		57-1/8 x 34-11/16 x 21-11/16		
Protection devices	High pressure protection	High pressure sensor, High pressure switch at 4.15 MPa (601 psi)		High pressure sensor, High pressure switch at 4.15 MPa (601 psi)		High pressure sensor, High pressure switch at 4.15 MPa (601 psi)		
	Inverter circuit (COMP.)	Over-heat protection, Over-current protection		Over-heat protection, Over-current protection		Over-heat protection, Over-current protection		
	Compressor	Over-heat protection		Over-heat protection		Over-heat protection		
Refrigerant	Type x original charge	R410A x 6.0 kg (14 lbs)		R410A x 11.7 kg (26 lbs)		R410A x 11.7 kg (26 lbs)		
Net weight	kg (lbs)	217 (479)		246 (543)		246 (543)		
Heat exchanger			plate type		plate type		plate type	
	Water volume in plate	L	5.0		10.0		10.0	
	Water pressure Max.	MPa	2.0		2.0		2.0	
Optional parts	Joint: CMY-Y102SS/LS-G2, CMY-Y202S-G2 Header: CMY-Y104, 108, 1010-G		Joint: CMY-Y102SS/LS-G2, CMY-Y202S-G2 Header: CMY-Y104, 108, 1010-G		Joint: CMY-Y102SS/LS-G2, CMY-Y202S-G2 Header: CMY-Y104, 108, 1010-G		Joint: CMY-Y102SS/LS-G2, CMY-Y202S-G2 Header: CMY-Y104, 108, 1010-G	

Notes:

*1,*2 Nominal conditions

	Indoor	Water temperature	Pipe length	Level difference
Cooling	27°C D.B./19°C W.B. (81°F D.B./66°F W.B.)	30°C (86°F)	7.5m (24-9/16ft.)	0m (0ft.)
Heating	20°C D.B. (68°F D.B.)	20°C (68°F)		

*The ambient temperature of the heat source unit needs to be kept below 40°C D.B.

*The ambient relative humidity of the heat source unit needs to be kept below 80%.

*The heat source unit should not be installed at outdoor.

*Be sure to mount a strainer (more than 50 meshes) at the water inlet piping of the unit.

*Be sure to provide interlocking for the unit operation and water circuit.

*Nominal condition *1,*2 are subject to JIS B8615-2.

*Due to continuing improvement, above specification may be subject to change without notice.

Outdoor Unit

HEAT SOURCE UNIT WY (Heat Pump) Series PQHY-P YSLM-A

NEW



► Specifications

Model		PQHY-P700YSLM-A		
Power source		3-phase 4-wire 380-400-415 V 50/60 Hz		
Cooling capacity (Nominal)	*1	kW	80.0	
		kcal / h	68,800	
		BTU / h	273,000	
	*1	kW	14.73	
		A	24.8-23.6-22.7	
	EER	kW / kW	5.43	
Temp. range of cooling	Indoor	W.B.	15.0~24.0°C (59~75°F)	
	Circulating water	°C	10.0~45.0°C (50~113°F)	
Heating capacity (Nominal)	*2	kW	88.0	
		kcal / h	75,700	
		BTU / h	300,300	
	*2	kW	14.73	
		A	24.8-23.6-22.7	
	COP	kW / kW	5.97	
Temp. range of heating	Indoor	D.B.	15.0~27.0°C (59~81°F)	
	Circulating water	°C	10.0~45.0°C (50~113°F)	
Indoor unit connectable	Total capacity	50~130% of heat source unit capacity		
	Model / Quantity	P15~P250/2~50		
Sound pressure level (measured in anechoic room)		dB <A>	55	
Refrigerant piping diameter	Liquid pipe	mm (in.)	19.05 (3/4) Brazed	
	Gas pipe	mm (in.)	34.93 (1-3/8) Brazed	
Set Model				
Model		PQHY-P350YLM-A	PQHY-P350YLM-A	
Circulating water	Water flow rate	m ³ / h	7.20 + 7.20	
		L/min	120 + 120	
		cfm	4.2 + 4.2	
	Pressure drop	kPa	44	44
	Operating volume range	m ³ / h	4.5 + 4.5 ~ 11.6 + 11.6	
Compressor	Type	Inverter scroll hermetic compressor		
	Starting method	Inverter	Inverter	
	Motor output	kW	9.5	9.5
	Case heater	kW	—	—
External finish	Galvanized steel sheets			
External dimension HxWxD	mm	1,450 x 880 x 550	1,450 x 880 x 550	
		in.	57-1/8 x 34-11/16 x 21-11/16	57-1/8 x 34-11/16 x 21-11/16
Protection devices	High pressure protection	High pressure sensor, High pressure switch at 4.15 MPa (601 psi)		
	Inverter circuit (COMP.)	Over-heat protection, Over-current protection		
	Compressor	Over-heat protection	Over-heat protection	
Refrigerant	Type x original charge	R410A x 6.0 kg (14 lbs)	R410A x 6.0 kg (14 lbs)	
Net weight	kg (lbs)	217 (479)	217 (479)	
Heat exchanger	plate type			
	Water volume in plate	L	5.0	5.0
	Water pressure Max.	MPa	2.0	2.0
Optional parts	Heat Source Twinning kit: CMY-Y200VBK2 Joint: CMY-Y102SS/LS-G2, CMY-Y202, 302S-G2 Header: CMY-Y104, 108, 1010-G			

Notes:

*1,*2 Nominal conditions

	Indoor	Water temperature	Pipe length	Level difference
Cooling	27°C D.B./19°C W.B. (81°F D.B./66°F W.B.)	30°C (86°F)	7.5m (24-9/16ft.)	0m (0ft.)
Heating	20°C D.B. (68°F D.B.)	20°C (68°F)		

*The ambient temperature of the heat source unit needs to be kept below 40°C D.B.

*The ambient relative humidity of the heat source unit needs to be kept below 80%.

*The heat source unit should not be installed at outdoor.

*Be sure to mount a strainer (more than 50 meshes) at the water inlet piping of the unit.

*Be sure to provide interlocking for the unit operation and water circuit.

*Nominal condition *1,*2 are subject to JIS B8615-2.

*Due to continuing improvement, above specification may be subject to change without notice.

HEAT SOURCE UNIT WY (Heat Pump) Series PQHY-P YSLM-A

NEW



► Specifications

Model		PQHY-P750YSLM-A		PQHY-P800YSLM-A						
Power source		3-phase 4-wire 380-400-415 V 50/60 Hz		3-phase 4-wire 380-400-415 V 50/60 Hz						
Cooling capacity (Nominal)	*1	kW	85.0	90.0						
	*1	kcal / h	73,100	77,400						
		BTU / h	290,000	307,100						
		Power input	kW	15.64	16.57					
		Current input	A	26.4-25.0-24.1	27.9-26.5-25.6					
	EER	kW / kW	5.43	5.43						
Temp. range of cooling	Indoor	W.B.	15.0~24.0°C (59~75°F)	15.0~24.0°C (59~75°F)						
	Circulating water	°C	10.0~45.0°C (50~113°F)	10.0~45.0°C (50~113°F)						
Heating capacity (Nominal)	*2	kW	95.0	100.0						
	*2	kcal / h	81,700	86,000						
		BTU / h	324,100	341,200						
		Power input	kW	15.90	16.75					
		Current input	A	26.8-25.4-24.5	28.2-26.8-25.8					
	COP	kW / kW	5.97	5.97						
Temp. range of heating	Indoor	D.B.	15.0~27.0°C (59~81°F)	15.0~27.0°C (59~81°F)						
	Circulating water	°C	10.0~45.0°C (50~113°F)	10.0~45.0°C (50~113°F)						
Indoor unit connectable	Total capacity	50~130% of heat source unit capacity		50~130% of heat source unit capacity						
	Model / Quantity	P15~P250/2~50		P15~P250/2~50						
Sound pressure level (measured in anechoic room)	dB <A>	55		55						
Refrigerant piping diameter	Liquid pipe	mm (in.)	19.05 (3/4) Brazed	19.05 (3/4) Brazed						
	Gas pipe	mm (in.)	34.93 (1-3/8) Brazed	34.93 (1-3/8) Brazed						
Set Model										
Model		PQHY-P400YLM-A		PQHY-P350YLM-A		PQHY-P400YLM-A		PQHY-P400YLM-A		
Circulating water	Water flow rate	m ³ / h	7.20 + 7.20		7.20 + 7.20					
		L/min	120 + 120		120 + 120					
		cfm	4.2 + 4.2		4.2 + 4.2					
	Pressure drop	kPa	44	44	44	44				
Operating volume range	m ³ / h	4.5 + 4.5 ~ 11.6 + 11.6				4.5 + 4.5 ~ 11.6 + 11.6				
Compressor	Type	Inverter scroll hermetic compressor				Inverter scroll hermetic compressor				
	Starting method	Inverter		Inverter		Inverter		Inverter		
	Motor output	10.7		9.5		10.7		10.7		
	Case heater	-		-		-		-		
External finish	Galvanized steel sheets		Galvanized steel sheets		Galvanized steel sheets		Galvanized steel sheets			
External dimension HxWxD	mm	1,450 x 880 x 550		1,450 x 880 x 550		1,450 x 880 x 550		1,450 x 880 x 550		
	in.	57-1/8 x 34-11/16 x 21-11/16		57-1/8 x 34-11/16 x 21-11/16		57-1/8 x 34-11/16 x 21-11/16		57-1/8 x 34-11/16 x 21-11/16		
Protection devices	High pressure protection	High pressure sensor, High pressure switch at 4.15 MPa (601 psi)				High pressure sensor, High pressure switch at 4.15 MPa (601 psi)				
	Inverter circuit (COMP.)	Over-heat protection, Over-current protection				Over-heat protection, Over-current protection				
	Compressor	Over-heat protection		Over-heat protection		Over-heat protection		Over-heat protection		
Refrigerant	Type x original charge	R410A x 6.0 kg (14 lbs)		R410A x 6.0 kg (14 lbs)		R410A x 6.0 kg (14 lbs)		R410A x 6.0 kg (14 lbs)		
Net weight	kg (lbs)	217 (479)		217 (479)		217 (479)		217 (479)		
Heat exchanger			plate type		plate type		plate type		plate type	
	Water volume in plate	L	5.0		5.0		5.0		5.0	
	Water pressure Max.	MPa	2.0		2.0		2.0		2.0	
Optional parts	Heat Source Twinning kit: CMY-Y200VBK2 Joint: CMY-Y102SS/LS-G2, CMY-Y202, 302S-G2 Header: CMY-Y104, 108, 1010-G				Heat Source Twinning kit: CMY-Y200VBK2 Joint: CMY-Y102SS/LS-G2, CMY-Y202, 302S-G2 Header: CMY-Y104, 108, 1010-G					

Notes:

*1,*2 Nominal conditions

	Indoor	Water temperature	Pipe length	Level difference
Cooling	27°C D.B./19°C W.B. (81°F D.B./66°F W.B.)	30°C (86°F)	7.5m (24-9/16ft.)	0m (0ft.)
Heating	20°C D.B. (68°F D.B.)	20°C (68°F)		

*The ambient temperature of the heat source unit needs to be kept below 40°C D.B.

*The ambient relative humidity of the heat source unit needs to be kept below 80%.

*The heat source unit should not be installed at outdoor.

*Be sure to mount a strainer (more than 50 meshes) at the water inlet piping of the unit.

*Be sure to provide interlocking for the unit operation and water circuit.

*Nominal condition *1,*2 are subject to JIS B8615-2.

*Due to continuing improvement, above specification may be subject to change without notice.

Outdoor Unit

HEAT SOURCE UNIT WY (Heat Pump) Series PQHY-P YSLM-A

NEW



► Specifications

Model		PQHY-P850YSLM-A		PQHY-P900YSLM-A		
Power source		3-phase 4-wire 380-400-415 V 50/60 Hz		3-phase 4-wire 380-400-415 V 50/60 Hz		
Cooling capacity (Nominal)	*1	kW	96.0	101.0		
	*1	kcal / h	82,600	86,900		
		BTU / h	327,600	344,600		
		Power input	kW	18.03	19.38	
		Current input	A	30.4-28.9-27.8	32.7-31.0-29.9	
	EER	kW / kW	5.32	5.21		
Temp. range of cooling	Indoor	W.B.	15.0~24.0°C (59~75°F)	15.0~24.0°C (59~75°F)		
	Circulating water	°C	10.0~45.0°C (50~113°F)	10.0~45.0°C (50~113°F)		
Heating capacity (Nominal)	*2	kW	108.0	113.0		
	*2	kcal / h	92,900	97,200		
		BTU / h	368,500	385,600		
		Power input	kW	18.49	19.74	
		Current input	A	31.2-29.6-28.5	33.3-31.6-30.5	
	COP	kW / kW	5.84	5.72		
Temp. range of heating	Indoor	D.B.	15.0~27.0°C (59~81°F)	15.0~27.0°C (59~81°F)		
	Circulating water	°C	10.0~45.0°C (50~113°F)	10.0~45.0°C (50~113°F)		
Indoor unit connectable	Total capacity	50~130% of heat source unit capacity		50~130% of heat source unit capacity		
	Model / Quantity	P15~P250/2~50		P15~P250/2~50		
Sound pressure level (measured in anechoic room)	dB <A>	56		57		
Refrigerant piping diameter	Liquid pipe	mm (in.)	19.05 (3/4) Brazed		19.05 (3/4) Brazed	
	Gas pipe	mm (in.)	41.28 (1-5/8) Brazed		41.28 (1-5/8) Brazed	
Set Model						
Model		PQHY-P450YLM-A		PQHY-P400YLM-A		
Circulating water	Water flow rate	m ³ / h	7.20 + 7.20		7.20 + 7.20	
		L/min	120 + 120		120 + 120	
		cfm	4.2 + 4.2		4.2 + 4.2	
	Pressure drop	kPa	44	44	44	44
	Operating volume range	m ³ / h	4.5 + 4.5 ~ 11.6 + 11.6		4.5 + 4.5 ~ 11.6 + 11.6	
Compressor	Type	Inverter scroll hermetic compressor		Inverter scroll hermetic compressor		
	Starting method	Inverter		Inverter		
	Motor output	kW	11.6	10.7	11.6	11.6
	Case heater	kW	-		-	
External finish	Galvanized steel sheets		Galvanized steel sheets		Galvanized steel sheets	
External dimension HxWxD	mm	1,450 x 880 x 550		1,450 x 880 x 550		
	in.	57-1/8 x 34-11/16 x 21-11/16		57-1/8 x 34-11/16 x 21-11/16		
Protection devices	High pressure protection	High pressure sensor, High pressure switch at 4.15 MPa (601 psi)		High pressure sensor, High pressure switch at 4.15 MPa (601 psi)		
	Inverter circuit (COMP.)	Over-heat protection, Over-current protection		Over-heat protection, Over-current protection		
	Compressor	Over-heat protection		Over-heat protection		
Refrigerant	Type x original charge	R410A x 6.0 kg (14 lbs)		R410A x 6.0 kg (14 lbs)		
Net weight	kg (lbs)	217 (479)		217 (479)		
Heat exchanger			plate type		plate type	
	Water volume in plate	L	5.0		5.0	
	Water pressure Max.	MPa	2.0		2.0	
Optional parts	Heat Source Twinning kit: CMY-Y200VBK2 Joint: CMY-Y102SS/LS-G2, CMY-Y202, 302S-G2 Header: CMY-Y104, 108, 1010-G		Heat Source Twinning kit: CMY-Y200VBK2 Joint: CMY-Y102SS/LS-G2, CMY-Y202, 302S-G2 Header: CMY-Y104, 108, 1010-G			

Notes:

*1,*2 Nominal conditions

	Indoor	Water temperature	Pipe length	Level difference
Cooling	27°C D.B./19°C W.B. (81°F D.B./66°F W.B.)	30°C (86°F)	7.5m (24-9/16ft.)	0m (0ft.)
Heating	20°C D.B. (68°F D.B.)	20°C (68°F)		

*The ambient temperature of the heat source unit needs to be kept below 40°C D.B.

*The ambient relative humidity of the heat source unit needs to be kept below 80%.

*The heat source unit should not be installed at outdoor.

*Be sure to mount a strainer (more than 50 meshes) at the water inlet piping of the unit.

*Be sure to provide interlocking for the unit operation and water circuit.

*Nominal condition *1,*2 are subject to JIS B8615-2.

*Due to continuing improvement, above specification may be subject to change without notice.

Outdoor Unit

OUTDOOR UNIT ZUBADAN (Heat Pump) Series(Y) PUHY-HP Y(S)HM-A(-BS)



► Specifications

Set name	PUHY-HP200YHM-A(-BS)		PUHY-HP250YHM-A(-BS)		PUHY-HP400YSHM-A(-BS)		PUHY-HP500YSHM-A(-BS)			
Power source	3-phase 4-wire 380-400-415V 50/60Hz									
Cooling capacity (Nominal)	*1	kW	22.4	28.0	45.0	56.0				
	*1	BTU/h	76,400	95,500	153,500	191,100				
		Power input kW	6.40	9.06	12.86	18.16				
		Current input A	10.8-10.2-9.8	15.2-14.5-14.0	21.7-20.6-19.8	30.6-29.1-28.0				
		COP	3.50	3.09	3.49	3.08				
Temp. range of cooling	Indoor	W.B.	15 ~ 24°C (59 ~ 75°F)							
	Outdoor	D.B.	- 5 ~ 43°C (23 ~ 109°F)							
Heating capacity (Nominal)	*2	kW	25.0	31.5	50.0	63.0				
	*2	BTU/h	85,300	107,500	170,600	215,000				
		Power input kW	6.52	8.94	13.35	18.04				
		Current input A	11.0-10.4-10.0	15.0-14.3-13.8	22.5-21.4-20.6	30.4-28.9-27.8				
		COP	3.83	3.52	3.74	3.49				
Temp. range of heating	Indoor	D.B.	15 ~ 27°C (59 ~ 81°F)							
	Outdoor	W.B.	-25 ~ 15.5°C (-13 ~ 60°F)							
Indoor unit connectable	Total capacity	50 ~ 130% of outdoor unit capacity								
	Model/Quantity	P15~P250 / 1~17		P15 ~ P250 / 1 ~ 21		P15 ~ P250 / 1 ~ 34		P15 ~ P250 / 1 ~ 43		
Sound pressure level (measured in anechoic room)	dB<A>	56		57		59		60		
Diameter of refrigerant pipe	Liquid pipe	mm(in.)	ø12.7 (ø1/2) Brazed		ø12.7 (ø1/2) Brazed		ø15.88 (ø5/8) Brazed		ø15.88 (ø5/8) Brazed	
	Gas pipe	mm(in.)	ø19.05 (ø3/4) Brazed		ø22.2 (ø7/8) Brazed		ø28.58 (ø1-1/8) Brazed		ø28.58 (ø1-1/8) Brazed	
Model		-								
External finish		Pre-coated galvanized steel sheets <MUNSELL 5Y 8/1 or similar>				Pre-coated galvanized steel sheets <MUNSELL 5Y 8/1 or similar>				
External dimension H x W x D	mm	1,710 (without legs 1,650) x 920 x 760		1,710 (without legs 1,650) x 920 x 760		1,710 (without legs 1,650) x 920 x 760		1,710 (without legs 1,650) x 920 x 760		
	in.	67-3/8 (without legs 65) x 36-1/4 x 29-15/16		67-3/8 (without legs 65) x 36-1/4 x 29-15/16		67-3/8 (without legs 65) x 36-1/4 x 29-15/16		67-3/8 (without legs 65) x 36-1/4 x 29-15/16		
Net weight	kg(lbs)	220 (486)		220 (486)		220 (486)		220 (486)		
Heat exchanger		Salt-resistant cross fin & copper tube				Salt-resistant cross fin & copper tube				
Compressor	Type	Inverter scroll hermetic compressor								
	Starting method	Inverter								
	Motor output	5.3		6.7		5.3		6.7		
FAN	*3	Air flow rate	m³/min		225		225		225	
			L/s		3,750		3,750		3,750	
			cfm		7,945		7,945		7,945	
		Type x Quantity	Propeller fan x 1		Propeller fan x 1		Propeller fan x 1		Propeller fan x 1	
	Motor output	0.92 x 1		0.92 x 1		0.92 x 1		0.92 x 1		
	External static press.	0 Pa (0 mmH ₂ O)		0 Pa (0 mmH ₂ O)		0 Pa (0 mmH ₂ O)		0 Pa (0 mmH ₂ O)		
Protection devices	High pressure protection	High pressure sensor, High pressure switch at 4.15 MPa (601 psi)								
	Inverter circuit (COMP./FAN)	Over-heat protection, Over-current protection								
	Compressor	Over-heat protection								
Refrigerant	Type x Original charge	R410A x 9.0kg (20 lbs)		R410A x 9.0kg (20 lbs)		R410A x 9.0kg (20 lbs)		R410A x 9.0kg (20 lbs)		
Pipe between unit distributor	Liquid pipe	mm(in.)	-		-		ø9.52 (ø3/8) Flare		ø9.52 (ø3/8) Flare	
	Gas pipe	mm(in.)	-		-		ø19.05 (ø3/4) Brazed		ø22.2 (ø7/8) Brazed	
Optional parts		Joint : CMY-Y102SS-G2 Header : CMY-Y104/108/1010-G				Outdoor Twinning kit : CMY-Y100VBK2 Joint : CMY-Y102SS/LS-G2, CMY-Y202S-G2 Header : CMY-Y104/108/1010-G				



Notes:

*1,*2 Nominal conditions

	Indoor	Outdoor	Pipe length	Level difference
Cooling	27°C DB/19°C WB (81°F DB/66°F WB)	35°C DB(95°F DB)	7.5m (24-9/16ft.)	0m (0ft.)
Heating	20°C DB(68°F DB)	7°C DB/6°C WB(45°F DB/43°F WB)	7.5m (24-9/16ft.)	0m (0ft.)

*3 External static pressure option is available (30Pa, 60Pa / 3.1mmH₂O, 6.1mmH₂O).

*Nominal condition *1,*2 are subject to JIS B8615-1.

*Due to continuing improvement, above specification may be subject to change without notice.

OUTDOOR UNIT

R2 Series

PURY-P YLM-A(-BS)



► Specifications

Model		PURY-P200YLM-A (-BS)	PURY-P250YLM-A (-BS)	
Power source		3-phase 4-wire 380-400-415 V 50/60 Hz		
Cooling capacity (Nominal)	*1 kW	22.4	28.0	
	*1 BTU / h	76,400	95,500	
	Power input kW	5.95	7.93	
	Current input A	10.0-9.5-9.1	13.3-12.7-12.2	
	EER kW / kW	3.76	3.53	
Temp. range of cooling	*3 Indoor W.B.	15.0~24.0°C (59~75°F)	15.0~24.0°C (59~75°F)	
	Outdoor D.B.	-5.0~46.0°C (23~115°F)	-5.0~46.0°C (23~115°F)	
Heating capacity (Nominal)	*2 kW	25.0	31.5	
	*2 BTU / h	85,300	107,500	
	Power input kW	6.54	8.65	
	Current input A	11.0-10.4-10.1	14.6-13.8-13.3	
	COP kW / kW	3.82	3.64	
Temp. range of heating	*3 Indoor D.B.	15.0~27.0°C (59~81°F)	15.0~27.0°C (59~81°F)	
	Outdoor W.B.	-20.0~15.5°C (-4~60°F)	-20.0~15.5°C (-4~60°F)	
Indoor unit connectable	Total capacity	50~150%	50~150% of outdoor unit capacity	
	Model / Quantity	P15~P250/1~20	P15~P250/1~25	
Sound pressure level (measured in anechoic room)	dB <A>	59	60	
Sound power level (measured in anechoic room)	dB <A>	82.5	83.5	
Refrigerant piping diameter	High pressure mm (in.)	15.88 (5/8) Brazed	19.05 (3/4) Brazed	
	Low pressure mm (in.)	19.05 (3/4) Brazed	22.2 (7/8) Brazed	
FAN	Type x Quantity	Propeller fan x 1	Propeller fan x 1	
	Air flow rate	m ³ /min	185	185
		L/s	3,083	3,083
		cfm	6,532	6,532
	Driving mechanism	Inverter-control, Direct-driven by motor	Inverter-control, Direct-driven by motor	
	Motor output kW	0.92 x 1	0.92 x 1	
	*4 External static press.	0 Pa (0 mmH ₂ O)	0 Pa (0 mmH ₂ O)	
Compressor	Type x Quantity	Inverter scroll hermetic compressor	Inverter scroll hermetic compressor	
	Starting method	Inverter	Inverter	
	Motor output kW	5.6	6.9	
	Case heater kW	-	-	
External finish		Pre-coated galvanized steel sheets (+powder coating for -BS type) <MUNSELL 5Y 8/1 or similar>	Pre-coated galvanized steel sheets (+powder coating for -BS type) <MUNSELL 5Y 8/1 or similar>	
External dimension HxWxD	mm	1,710 (1,650 without legs) x 920 x 740	1,710 (1,650 without legs) x 920 x 740	
	in.	67-3/8 (65 without legs) x 36-1/4 x 29-3/16	67-3/8 (65 without legs) x 36-1/4 x 29-3/16	
Protection devices	High pressure protection	High pressure sensor, High pressure switch at 4.15 MPa (601 psi)	High pressure sensor, High pressure switch at 4.15 MPa (601 psi)	
	Inverter circuit (COMP./FAN)	Over-heat protection, Over-current protection	Over-heat protection, Over-current protection	
	Compressor	Over-heat protection	Over-heat protection	
	Fan motor	Over-current protection	Over-current protection	
Refrigerant	Type x original charge	R410A x 9.5 kg (21 lbs)	R410A x 9.5 kg (21 lbs)	
Net weight	kg (lbs)	205 (452)	205 (452)	
Heat exchanger		Salt-resistant cross fin & copper tube	Salt-resistant cross fin & copper tube	
Optional parts		Joint: CMY-Y102SS-G2,CMY-Y102LS-G2,CMY-R160-J1 BC controller: CMB-P104,105,106,108,1010,1013,1016V-G1 Main BC controller: CMB-P108,1010,1013,1016V-GA1 Sub BC controller: CMB-P104,108V-GB1,CMB-P1016V-HB1	Joint: CMY-Y102SS-G2,CMY-Y102LS-G2,CMY-R160-J1 BC controller: CMB-P104,105,106,108,1010,1013,1016V-G1 Main BC controller: CMB-P108,1010,1013,1016V-GA1 Sub BC controller: CMB-P104,108V-GB1,CMB-P1016V-HB1	

Notes:

*1,*2 Nominal conditions

	Indoor	Outdoor	Pipe length	Level difference
Cooling	27°C DB/19°C WB (81°F DB/66°F WB)	35°C DB/24°C WB (95°F DB/75°F WB)	7.5m (24-9/16ft.)	0m (0ft.)
Heating	20°C DB(68°F DB)	7°C DB/6°C WB(45°F DB/43°F WB)	7.5m (24-9/16ft.)	0m (0ft.)

*3 -5°C DB (23°F DB) / -6°C WB (21°F WB) to 21°C DB (70°F DB) / 15.5°C WB (60°F WB) with cooling/heating mixed operation.

*4 External static pressure option is available (30Pa, 60Pa / 3.1mmH₂O, 6.1mmH₂O).

*Nominal condition *1,*2 are subject to JIS B8615-1.

*Due to continuing improvement, above specification may be subject to change without notice.

OUTDOOR UNIT

R2 Series

PURY-P YLM-A(-BS)



► Specifications

Model		PURY-P300YLM-A (-BS)	PURY-P350YLM-A (-BS)	
Power source		3-phase 4-wire 380-400-415 V 50/60 Hz		
Cooling capacity (Nominal)	*1 kW	33.5	40.0	
	*1 BTU / h	114,300	136,500	
	Power input kW	9.82	12.69	
	Current input A	16.5-15.7-15.1	21.4-20.3-19.6	
	EER kW / kW	3.41	3.15	
Temp. range of cooling	*3 Indoor W.B.	15.0~24.0°C (59~75°F)	15.0~24.0°C (59~75°F)	
	Outdoor D.B.	-5.0~46.0°C (23~115°F)	-5.0~46.0°C (23~115°F)	
Heating capacity (Nominal)	*2 kW	37.5	45.0	
	*2 BTU / h	128,000	153,500	
	Power input kW	10.77	12.97	
	Current input A	18.1-17.2-16.6	21.8-20.8-20.0	
	COP kW / kW	3.48	3.46	
Temp. range of heating	*3 Indoor D.B.	15.0~27.0°C (59~81°F)	15.0~27.0°C (59~81°F)	
	Outdoor W.B.	-20.0~15.5°C (-4~60°F)	-20.0~15.5°C (-4~60°F)	
Indoor unit connectable	Total capacity	50~150% of outdoor unit capacity	50~150% of outdoor unit capacity	
	Model / Quantity	P15-P250/1~30	P15-P250/1~35	
Sound pressure level (measured in anechoic room)	dB <A>	62.5	62.5	
Sound power level (measured in anechoic room)	dB <A>	86	86	
Refrigerant piping diameter	High pressure mm (in.)	19.05 (3/4) Brazed	19.05 (3/4) Brazed	
	Low pressure mm (in.)	22.2 (7/8) Brazed	28.58 (1-1/8) Brazed	
FAN	Type x Quantity	Propeller fan x 1	Propeller fan x 1	
	Air flow rate	m ³ /min	230	230
		L/s	3,833	3,833
		cfm	8,121	8,121
	Driving mechanism	Inverter-control, Direct-driven by motor	Inverter-control, Direct-driven by motor	
	Motor output kW	0.92 x 1	0.92 x 1	
*4 External static press.	0 Pa (0 mmH ₂ O)	0 Pa (0 mmH ₂ O)		
Compressor	Type x Quantity	Inverter scroll hermetic compressor	Inverter scroll hermetic compressor	
	Starting method	Inverter	Inverter	
	Motor output kW	8.1	10.5	
	Case heater kW	—	—	
External finish		Pre-coated galvanized steel sheets (+powder coating for -BS type) <MUNSELL 5Y 8/1 or similar>	Pre-coated galvanized steel sheets (+powder coating for -BS type) <MUNSELL 5Y 8/1 or similar>	
External dimension HxWxD	mm	1,710 (1,650 without legs) x 1,220 x 740	1,710 (1,650 without legs) x 1,220 x 740	
	in.	67-3/8 (65 without legs) x 48-1/16 x 29-3/16	67-3/8 (65 without legs) x 48-1/16 x 29-3/16	
Protection devices	High pressure protection	High pressure sensor, High pressure switch at 4.15 MPa (601 psi)	High pressure sensor, High pressure switch at 4.15 MPa (601 psi)	
	Inverter circuit (COMP./FAN)	Over-heat protection, Over-current protection	Over-heat protection, Over-current protection	
	Compressor	Over-heat protection	Over-heat protection	
	Fan motor	Over-current protection	Over-current protection	
Refrigerant	Type x original charge	R410A x 10.3 kg (23 lbs)	R410A x 10.3 kg (23 lbs)	
Net weight	kg (lbs)	248 (547)	248 (547)	
Heat exchanger		Salt-resistant cross fin & copper tube	Salt-resistant cross fin & copper tube	
Optional parts		Joint: CMY-Y102SS-G2,CMY-Y102LS-G2,CMY-R160-J1 BC controller: CMB-P104,105,106,108,1010,1013,1016V-G1 Main BC controller: CMB-P108,1010,1013,1016V-GA1 Sub BC controller: CMB-P104,108V-GB1,CMB-P1016V-HB1	Joint: CMY-Y102SS-G2,CMY-Y102LS-G2,CMY-R160-J1 BC controller: CMB-P104,105,106,108,1010,1013,1016V-G1 Main BC controller: CMB-P108,1010,1013,1016V-GA1 Sub BC controller: CMB-P104,108V-GB1,CMB-P1016V-HB1	

Notes:

*1,*2 Nominal conditions

	Indoor	Outdoor	Pipe length	Level difference
Cooling	27°C DB/19°C WB (81°F DB/66°F WB)	35°C DB/24°C WB (95°F DB/75°F WB)	7.5m (24-9/16ft.)	0m (0ft.)
Heating	20°C DB(68°F DB)	7°C DB/6°C WB(45°F DB/43°F WB)	7.5m (24-9/16ft.)	0m (0ft.)

*3 -5°C DB (23°F DB) / -6°C WB (21°F WB) to 21°C DB (70°F DB) / 15.5°C WB (60°F WB) with cooling/heating mixed operation.

*4 External static pressure option is available (30Pa, 60Pa / 3.1mmH₂O, 6.1mmH₂O).

*Nominal condition *1,*2 are subject to JIS B8615-1.

*Due to continuing improvement, above specification may be subject to change without notice.



OUTDOOR UNIT

R2 Series

PURY-P YSLM-A(-BS)



► Specifications

Model		PURY-P400YSLM-A (-BS)		PURY-P450YSLM-A (-BS)		PURY-P500YSLM-A (-BS)		
Power source		3-phase 4-wire 380-400-415 V 50/60 Hz		3-phase 4-wire 380-400-415 V 50/60 Hz		3-phase 4-wire 380-400-415 V 50/60 Hz		
Cooling capacity (Nominal)	*1 kW	45.0		50.0		56.0		
	*1 BTU / h	153,500		170,600		191,100		
	Power input kW	12.36		14.16		16.37		
	Current input A	20.8-19.8-19.1		23.9-22.7-21.8		27.6-26.2-25.3		
EER	kW / kW	3.64		3.53		3.42		
Temp. range of cooling	*3 Indoor W.B.	15.0~24.0°C (59~75°F)		15.0~24.0°C (59~75°F)		15.0~24.0°C (59~75°F)		
	Outdoor D.B.	-5.0~46.0°C (23~115°F)		-5.0~46.0°C (23~115°F)		-5.0~46.0°C (23~115°F)		
Heating capacity (Nominal)	*2 kW	50.0		56.0		63.0		
	*2 BTU / h	170,600		191,100		215,000		
	Power input kW	13.08		15.01		17.30		
	Current input A	22.0-20.9-20.2		25.3-24.0-23.2		29.2-27.7-26.7		
COP	kW / kW	3.82		3.73		3.64		
Temp. range of heating	*3 Indoor D.B.	15.0~27.0°C (59~81°F)		15.0~27.0°C (59~81°F)		15.0~27.0°C (59~81°F)		
	Outdoor W.B.	-20.0~15.5°C (-4~60°F)		-20.0~15.5°C (-4~60°F)		-20.0~15.5°C (-4~60°F)		
Indoor unit connectable	Total capacity	50~150% of outdoor unit capacity		50~150% of outdoor unit capacity		50~150% of outdoor unit capacity		
	Model / Quantity	P15-P250/1~40		P15-P250/1~45		P15-P250/1~50		
Sound pressure level (measured in anechoic room)	dB <A>	62		62.5		63		
Sound power level (measured in anechoic room)	dB <A>	85.5		86		86.5		
Refrigerant piping diameter	High pressure mm (in.)	22.2 (7/8) Brazed		22.2 (7/8) Brazed		22.2 (7/8) Brazed		
	Low pressure mm (in.)	28.58 (1-1/8) Brazed		28.58 (1-1/8) Brazed		28.58 (1-1/8) Brazed		
Set Model								
Model		PURY-P200YLM-A (-BS)		PURY-P200YLM-A (-BS)		PURY-P250YLM-A (-BS)		
FAN	Type x Quantity	Propeller fan x 1		Propeller fan x 1		Propeller fan x 1		
	Air flow rate	m ³ /min	185		185		185	
		L/s	3,083		3,083		3,083	
		cfm	6,532		6,532		6,532	
Driving mechanism	Inverter-control, Direct-driven by motor		Inverter-control, Direct-driven by motor		Inverter-control, Direct-driven by motor			
Motor output	kW	0.92 x 1		0.92 x 1		0.92 x 1		
	External static press.	0 Pa (0 mmH ₂ O)		0 Pa (0 mmH ₂ O)		0 Pa (0 mmH ₂ O)		
Compressor	Type x Quantity	Inverter scroll hermetic compressor		Inverter scroll hermetic compressor		Inverter scroll hermetic compressor		
	Starting method	Inverter		Inverter		Inverter		
	Motor output kW	5.6		5.6		6.9		
	Case heater kW	-		-		-		
External finish		Pre-coated galvanized steel sheets (+powder coating for -BS type) <MUNSELL 5Y 8/1 or similar>		Pre-coated galvanized steel sheets (+powder coating for -BS type) <MUNSELL 5Y 8/1 or similar>		Pre-coated galvanized steel sheets (+powder coating for -BS type) <MUNSELL 5Y 8/1 or similar>		
External dimension HxWxD	mm	1,710 (1,650 without legs) x 920 x 740		1,710 (1,650 without legs) x 920 x 740		1,710 (1,650 without legs) x 920 x 740		
	in.	67-3/8 (65 without legs) x 36-1/4 x 29-3/16		67-3/8 (65 without legs) x 36-1/4 x 29-3/16		67-3/8 (65 without legs) x 36-1/4 x 29-3/16		
Protection devices	High pressure protection	High pressure sensor, High pressure switch at 4.15 MPa (601 psi)		High pressure sensor, High pressure switch at 4.15 MPa (601 psi)		High pressure sensor, High pressure switch at 4.15 MPa (601 psi)		
	Inverter circuit (COMP/FAN)	Over-heat protection, Over-current protection		Over-heat protection, Over-current protection		Over-heat protection, Over-current protection		
	Compressor	Over-heat protection Over-heat protection		Over-heat protection Over-heat protection		Over-heat protection Over-heat protection		
	Fan motor	Over-current protection		Over-current protection		Over-current protection		
Refrigerant	Type x original charge	R410A x 9.5 kg (21 lbs) R410A x 9.5 kg (21 lbs)		R410A x 9.5 kg (21 lbs) R410A x 9.5 kg (21 lbs)		R410A x 9.5 kg (21 lbs) R410A x 9.5 kg (21 lbs)		
Net weight	kg (lbs)	205 (452) 205 (452)		205 (452) 205 (452)		205 (452) 205 (452)		
Heat exchanger		Salt-resistant cross fin & copper tube		Salt-resistant cross fin & copper tube		Salt-resistant cross fin & copper tube		
Pipe between unit and distributor	High pressure mm (in.)	15.88 (5/8) Brazed 15.88 (5/8) Brazed		15.88 (5/8) Brazed 19.05 (3/4) Brazed		19.05 (3/4) Brazed 19.05 (3/4) Brazed		
	Low pressure mm (in.)	19.05 (3/4) Brazed -		19.05 (3/4) Brazed -		22.2 (7/8) Brazed -		
Optional parts		Outdoor Twinning kit: CMY-R100VBK-A Joint: CMY-Y102S-G2,CMY-Y102L-G2,CMY-R160-J1 Main BC controller: CMB-P108,1010,1013,1016V-GA1 Sub BC controller: CMB-P104,108V-GB1,CMB-P1016V-HB1		Outdoor Twinning kit: CMY-R100VBK-A Joint: CMY-Y102S-G2,CMY-Y102L-G2,CMY-R160-J1 Main BC controller: CMB-P108,1010,1013,1016V-GA1 Sub BC controller: CMB-P104,108V-GB1,CMB-P1016V-HB1		Outdoor Twinning kit: CMY-R100VBK-A Joint: CMY-Y102S-G2,CMY-Y102L-G2,CMY-R160-J1 Main BC controller: CMB-P108,1010,1013,1016V-GA1 Sub BC controller: CMB-P104,108V-GB1,CMB-P1016V-HB1		

Notes:

*1,*2 Nominal conditions

	Indoor	Outdoor	Pipe length	Level difference
Cooling	27°C DB/19°C WB (81°F DB/66°F WB)	35°C DB/24°C WB (95°F DB/75°F WB)	7.5m (24-9/16ft.)	0m (0ft.)
Heating	20°C DB(68°F DB)	7°C DB/6°C WB(45°F DB/43°F WB)	7.5m (24-9/16ft.)	0m (0ft.)

*3 -5°C DB (23°F DB) / -6°C WB (21°F WB) to 21°C DB (70°F DB) / 15.5°C WB (60°F WB) with cooling/heating mixed operation.

*4 External static pressure option is available (30Pa, 60Pa / 3.1mmH₂O, 6.1mmH₂O).

*Nominal condition *1,*2 are subject to JIS B8615-1.

*Due to continuing improvement, above specification may be subject to change without notice.

OUTDOOR UNIT

R2 Series

PURY-P YSLM-A(-BS)

► Specifications



Model		PURY-P550YSLM-A (-BS)	PURY-P600YSLM-A (-BS)	PURY-P650YSLM-A (-BS)				
Power source		3-phase 4-wire 380-400-415 V 50/60 Hz		3-phase 4-wire 380-400-415 V 50/60 Hz				
Cooling capacity (Nominal)	*1 kW	63.0	69.0	73.0				
	*1 BTU / h	215,000	235,400	249,100				
	Power input kW	18.75	20.90	22.95				
	Current input A	31.6-30.0-28.9	35.2-33.5-32.3	38.7-36.8-35.4				
	EER kW / kW	3.36	3.30	3.18				
Temp. range of cooling	*3 Indoor W.B.	15.0~24.0°C (59~75°F)	15.0~24.0°C (59~75°F)	15.0~24.0°C (59~75°F)				
	Outdoor D.B.	-5.0~46.0°C (23~115°F)	-5.0~46.0°C (23~115°F)	-5.0~46.0°C (23~115°F)				
Heating capacity (Nominal)	*2 kW	69.0	76.5	81.5				
	*2 BTU / h	235,400	261,000	278,100				
	Power input kW	19.38	21.98	23.48				
	Current input A	32.7-31.0-29.9	37.1-35.2-33.9	39.6-37.6-36.2				
	COP kW / kW	3.56	3.48	3.47				
Temp. range of heating	*3 Indoor D.B.	15.0~27.0°C (59~81°F)	15.0~27.0°C (59~81°F)	15.0~27.0°C (59~81°F)				
	Outdoor W.B.	-20.0~15.5°C (-4~60°F)	-20.0~15.5°C (-4~60°F)	-20.0~15.5°C (-4~60°F)				
Indoor unit connectable	Total capacity	50~150% of outdoor unit capacity		50~150% of outdoor unit capacity				
	Model / Quantity	P15-P250/2~50		P15-P250/2~50				
Sound pressure level (measured in anechoic room)	dB <A>	64.5	65.5	65.5				
Sound power level (measured in anechoic room)	dB <A>	88	89	89				
Refrigerant piping diameter	High pressure mm (in.)	28.58 (1-1/8) Brazed	28.58 (1-1/8) Brazed	28.58 (1-1/8) Brazed				
	Low pressure mm (in.)	28.58 (1-1/8) Brazed	28.58 (1-1/8) Brazed	28.58 (1-1/8) Brazed				
Set Model								
Model		PURY-P250YLM-A (-BS)	PURY-P300YLM-A (-BS)	PURY-P300YLM-A (-BS)	PURY-P300YLM-A (-BS)	PURY-P300YLM-A (-BS)	PURY-P350YLM-A (-BS)	
FAN	Type x Quantity	Propeller fan x 1		Propeller fan x 1		Propeller fan x 1		
	Air flow rate	m ³ /min	185	230	230		230	
		L/s	3,083	3,833	3,833		3,833	
		cfm	6,532	8,121	8,121		8,121	
	Driving mechanism	Inverter-control, Direct-driven by motor		Inverter-control, Direct-driven by motor		Inverter-control, Direct-driven by motor		
*4 Motor output kW	0.92 x 1	0.92 x 1	0.92 x 1	0.92 x 1	0.92 x 1	0.92 x 1		
External static press.	0 Pa (0 mmH ₂ O)		0 Pa (0 mmH ₂ O)		0 Pa (0 mmH ₂ O)		0 Pa (0 mmH ₂ O)	
Compressor	Type x Quantity	Inverter scroll hermetic compressor		Inverter scroll hermetic compressor		Inverter scroll hermetic compressor		
	Starting method	Inverter	Inverter	Inverter	Inverter	Inverter	Inverter	
	Motor output kW	6.9	8.1	8.1	8.1	8.1	10.5	
	Case heater kW	-	-	-	-	-	-	
External finish	Pre-coated galvanized steel sheets (+powder coating for -BS type) <MUNSELL 5Y 8/1 or similar>		Pre-coated galvanized steel sheets (+powder coating for -BS type) <MUNSELL 5Y 8/1 or similar>		Pre-coated galvanized steel sheets (+powder coating for -BS type) <MUNSELL 5Y 8/1 or similar>			
External dimension HxWxD	mm	1,710 (1,650 without legs) x 920 x 740	1,710 (1,650 without legs) x 1,220 x 740	1,710 (1,650 without legs) x 1,220 x 740	1,710 (1,650 without legs) x 1,220 x 740	1,710 (1,650 without legs) x 1,220 x 740	1,710 (1,650 without legs) x 1,220 x 740	
	in.	67-3/8 (65 without legs) x 36-1/4 x 29-3/16	67-3/8 (65 without legs) x 48-1/16 x 29-3/16	67-3/8 (65 without legs) x 48-1/16 x 29-3/16	67-3/8 (65 without legs) x 48-1/16 x 29-3/16	67-3/8 (65 without legs) x 48-1/16 x 29-3/16	67-3/8 (65 without legs) x 48-1/16 x 29-3/16	
Protection devices	High pressure protection	High pressure sensor, High pressure switch at 4.15 MPa (601 psi)		High pressure sensor, High pressure switch at 4.15 MPa (601 psi)		High pressure sensor, High pressure switch at 4.15 MPa (601 psi)		
	Inverter circuit (COMP./FAN)	Over-heat protection, Over-current protection		Over-heat protection, Over-current protection		Over-heat protection, Over-current protection		
	Compressor	Over-heat protection	Over-heat protection	Over-heat protection	Over-heat protection	Over-heat protection	Over-heat protection	
	Fan motor	Over-current protection		Over-current protection		Over-current protection		
Refrigerant	Type x original charge	R410A x 9.5 kg (21 lbs)	R410A x 10.3 kg (23 lbs)	R410A x 10.3 kg (23 lbs)	R410A x 10.3 kg (23 lbs)	R410A x 10.3 kg (23 lbs)	R410A x 10.3 kg (23 lbs)	
Net weight	kg (lbs)	205 (452)	248 (547)	248 (547)	248 (547)	248 (547)	248 (547)	
Heat exchanger	Salt-resistant cross fin & copper tube		Salt-resistant cross fin & copper tube		Salt-resistant cross fin & copper tube			
Pipe between unit and distributor	High pressure mm (in.)	19.05 (3/4) Brazed	19.05 (3/4) Brazed	19.05 (3/4) Brazed	19.05 (3/4) Brazed	19.05 (3/4) Brazed	19.05 (3/4) Brazed	
	Low pressure mm (in.)	22.2 (7/8) Brazed	-	22.2 (7/8) Brazed	-	22.2 (7/8) Brazed	-	
Optional parts	Outdoor Twinning kit: CMY-R100VBK2 Joint: CMY-Y102SS-G2, CMY-Y102LS-G2, CMY-R160-J1 Main BC controller: CMB-P108, 1010, 1013, 1016V-GA1 Sub BC controller: CMB-P104, 108V-GB1, CMB-P1016V-HB1		Outdoor Twinning kit: CMY-R100VBK2 Joint: CMY-Y102SS-G2, CMY-Y102LS-G2, CMY-R160-J1 Main BC controller: CMB-P108, 1010, 1013, 1016V-GA1 Sub BC controller: CMB-P104, 108V-GB1, CMB-P1016V-HB1		Outdoor Twinning kit: CMY-R100VBK2 Joint: CMY-Y102SS-G2, CMY-Y102LS-G2, CMY-R160-J1 Main BC controller: CMB-P108, 1010, 1013, 1016V-GA1 Sub BC controller: CMB-P104, 108V-GB1, CMB-P1016V-HB1			

Notes:

*1,*2 Nominal conditions

	Indoor	Outdoor	Pipe length	Level difference
Cooling	27°C DB/19°C WB (81°F DB/66°F WB)	35°C DB/24°C WB (95°F DB/75°F WB)	7.5m (24-9/16ft.)	0m (0ft.)
Heating	20°C DB/68°F DB)	7°C DB/6°C WB(45°F DB/43°F WB)	7.5m (24-9/16ft.)	0m (0ft.)

*3 -5°C DB (23°F DB) / -6°C WB (21°F WB) to 21°C DB (70°F DB) / 15.5°C WB (60°F WB) with cooling/heating mixed operation.

*4 External static pressure option is available (30Pa, 60Pa / 3.1mmH₂O, 6.1mmH₂O).

*Nominal condition *1,*2 are subject to JIS B8615-1.

*Due to continuing improvement, above specification may be subject to change without notice.

OUTDOOR UNIT

R2 Series

PURY-P YSLM-A(-BS)



► Specifications

Model		PURY-P700YSLM-A (-BS)		PURY-P750YSLM-A (-BS)		PURY-P800YSLM-A (-BS)		
Power source		3-phase 4-wire 380-400-415 V 50/60 Hz		3-phase 4-wire 380-400-415 V 50/60 Hz		3-phase 4-wire 380-400-415 V 50/60 Hz		
Cooling capacity (Nominal)	*1 kW	80.0		85.0		90.0		
	*1 BTU / h	273,000		290,000		307,100		
	Power input kW	26.22		28.23		30.30		
	Current input A	44.2-42.0-40.5		47.6-45.2-43.6		51.1-48.5-46.8		
EER	kW / kW	3.05		3.01		2.97		
Temp. range of cooling	*3 Indoor W.B.	15.0~24.0°C (59~75°F)		15.0~24.0°C (59~75°F)		15.0~24.0°C (59~75°F)		
	Outdoor D.B.	-5.0~46.0°C (23~115°F)		-5.0~46.0°C (23~115°F)		-5.0~46.0°C (23~115°F)		
Heating capacity (Nominal)	*2 kW	88.0		90.0		90.0		
	*2 BTU / h	300,300		307,100		307,100		
	Power input kW	25.43		25.49		24.93		
	Current input A	42.9-40.7-39.3		43.0-40.8-39.4		42.0-39.9-38.5		
COP	kW / kW	3.46		3.53		3.61		
Temp. range of heating	*3 Indoor D.B.	15.0~27.0°C (59~81°F)		15.0~27.0°C (59~81°F)		15.0~27.0°C (59~81°F)		
	Outdoor W.B.	-20.0~15.5°C (-4~60°F)		-20.0~15.5°C (-4~60°F)		-20.0~15.5°C (-4~60°F)		
Indoor unit connectable	Total capacity	50~150% of outdoor unit capacity		50~150% of outdoor unit capacity		50~150% of outdoor unit capacity		
	Model / Quantity	P15-P250/2~50		P15-P250/2~50		P15-P250/2~50		
Sound pressure level (measured in anechoic room)	dB <A>	65.5		65.5		65.5		
Sound power level (measured in anechoic room)	dB <A>	89		89		89		
Refrigerant piping diameter	High pressure mm (in.)	28.58 (1-1/8) Brazed		28.58 (1-1/8) Brazed		28.58 (1-1/8) Brazed		
	Low pressure mm (in.)	34.93 (1-3/8) Brazed		34.93 (1-3/8) Brazed		34.93 (1-3/8) Brazed		
Set Model								
Model		PURY-P350YLM-A (-BS)		PURY-P350YLM-A (-BS)		PURY-P400YLM-A (-BS)		
FAN	Type x Quantity	Propeller fan x 1		Propeller fan x 1		Propeller fan x 1		
	Air flow rate	m ³ /min	230		230		230	
		L/s	3,833		3,833		3,833	
		cfm	8,121		8,121		8,121	
Driving mechanism	Inverter-control, Direct-driven by motor		Inverter-control, Direct-driven by motor		Inverter-control, Direct-driven by motor			
Motor output	kW	0.92 x 1		0.92 x 1		0.92 x 1		
	External static press.	0 Pa (0 mmH ₂ O)		0 Pa (0 mmH ₂ O)		0 Pa (0 mmH ₂ O)		
Compressor	Type x Quantity	Inverter scroll hermetic compressor		Inverter scroll hermetic compressor		Inverter scroll hermetic compressor		
	Starting method	Inverter		Inverter		Inverter		
	Motor output kW	10.5		10.5		10.9		
	Case heater kW	-		-		-		
External finish		Pre-coated galvanized steel sheets (+powder coating for -BS type) <MUNSELL 5Y 8/1 or similar>		Pre-coated galvanized steel sheets (+powder coating for -BS type) <MUNSELL 5Y 8/1 or similar>		Pre-coated galvanized steel sheets (+powder coating for -BS type) <MUNSELL 5Y 8/1 or similar>		
External dimension HxWxD	mm	1,710 (1,650 without legs) x 1,220 x 740		1,710 (1,650 without legs) x 1,220 x 740		1,710 (1,650 without legs) x 1,220 x 740		
	in.	67-3/8 (65 without legs) x 48-1/16 x 29-3/16		67-3/8 (65 without legs) x 48-1/16 x 29-3/16		67-3/8 (65 without legs) x 48-1/16 x 29-3/16		
Protection devices	High pressure protection	High pressure sensor, High pressure switch at 4.15 MPa (601 psi)		High pressure sensor, High pressure switch at 4.15 MPa (601 psi)		High pressure sensor, High pressure switch at 4.15 MPa (601 psi)		
	Inverter circuit (COMP./FAN)	Over-heat protection, Over-current protection		Over-heat protection, Over-current protection		Over-heat protection, Over-current protection		
	Compressor	Over-heat protection Over-heat protection		Over-heat protection Over-heat protection		Over-heat protection Over-heat protection		
	Fan motor	Over-current protection		Over-current protection		Over-current protection		
Refrigerant	Type x original charge	R410A x 10.3 kg (23 lbs)		R410A x 10.3 kg (23 lbs)		R410A x 10.3 kg (23 lbs)		
Net weight	kg (lbs)	248 (547)		248 (547)		246 (543)		
Heat exchanger		Salt-resistant cross fin & copper tube		Salt-resistant cross fin & copper tube		Salt-resistant cross fin & copper tube		
Pipe between unit and distributor	High pressure mm (in.)	19.05 (3/4) Brazed		19.05 (3/4) Brazed		22.2 (7/8) Brazed		
	Low pressure mm (in.)	28.58 (1-1/8) Brazed		28.58 (1-1/8) Brazed		28.58 (1-1/8) Brazed		
Outdoor parts		Outdoor Twinning kit: CMY-R200VBK2 Joint: CMY-Y102SS-G2, CMY-Y102LS-G2, CMY-R160-J1 Main BC controller: CMB-P1016V-HA1 Sub BC controller: CMB-P104, 108V-GB1, CMB-P1016V-HB1		Outdoor Twinning kit: CMY-R200VBK2 Joint: CMY-Y102SS-G2, CMY-Y102LS-G2, CMY-R160-J1 Main BC controller: CMB-P1016V-HA1 Sub BC controller: CMB-P104, 108V-GB1, CMB-P1016V-HB1		Outdoor Twinning kit: CMY-R200VBK2 Joint: CMY-Y102SS-G2, CMY-Y102LS-G2, CMY-R160-J1 Main BC controller: CMB-P1016V-HA1 Sub BC controller: CMB-P104, 108V-GB1, CMB-P1016V-HB1		

Notes:

*1,*2 Nominal conditions

	Indoor	Outdoor	Pipe length	Level difference
Cooling	27°C DB/19°C WB (81°F DB/66°F WB)	35°C DB/24°C WB (95°F DB/75°F WB)	7.5m (24-9/16ft.)	0m (0ft.)
Heating	20°C DB(68°F DB)	7°C DB/6°C WB(45°F DB/43°F WB)	7.5m (24-9/16ft.)	0m (0ft.)

*3 -5°C DB (23°F DB) / -6°C WB (21°F WB) to 21°C DB (70°F DB) / 15.5°C WB (60°F WB) with cooling/heating mixed operation.

*4 External static pressure option is available (30Pa, 60Pa / 3.1mmH₂O, 6.1mmH₂O).

*Nominal condition *1,*2 are subject to JIS B8615-1.

*Due to continuing improvement, above specification may be subject to change without notice.

OUTDOOR UNIT

R2 Series

PURY-P YSLM-A(-BS)



► Specifications

Model		PURY-P850YSLM-A (-BS)		PURY-P900YSLM-A (-BS)		
Power source		3-phase 4-wire 380-400-415 V 50/60 Hz		3-phase 4-wire 380-400-415 V 50/60 Hz		
Cooling capacity (Nominal)	*1 kW	96.0		101.0		
	*1 BTU / h	327,600		344,600		
	Power input kW	31.16		31.56		
	Current input A	52.6-49.9-48.1		53.2-50.6-48.7		
EER		3.08		3.20		
Temp. range of cooling	*3 Indoor W.B.	15.0~24.0°C (59~75°F)		15.0~24.0°C (59~75°F)		
	Outdoor D.B.	-5.0~46.0°C (23~115°F)		-5.0~46.0°C (23~115°F)		
Heating capacity (Nominal)	*2 kW	101.0		113.0		
	*2 BTU / h	344,600		385,600		
	Power input kW	28.53		32.47		
	Current input A	48.1-45.7-44.1		54.8-52.0-50.1		
COP		3.54		3.48		
Temp. range of heating	*3 Indoor D.B.	15.0~27.0°C (59~81°F)		15.0~27.0°C (59~81°F)		
	Outdoor W.B.	-20.0~15.5°C (-4~60°F)		-20.0~15.5°C (-4~60°F)		
Indoor unit connectable	Total capacity	50~150% of outdoor unit capacity		50~150% of outdoor unit capacity		
	Model / Quantity	P15-P250/2~50		P15-P250/2~50		
Sound pressure level (measured in anechoic room)	dB <A>	65.5		65.5		
Sound power level (measured in anechoic room)	dB <A>	89		89		
Refrigerant piping diameter	High pressure mm (in.)	28.58 (1-1/8) Brazed		28.58 (1-1/8) Brazed		
	Low pressure mm (in.)	41.28 (1-5/8) Brazed		41.28 (1-5/8) Brazed		
Set Model						
Model		PURY-P400YLM-A (-BS)		PURY-P450YLM-A (-BS)		
FAN	Type x Quantity	Propeller fan x 1		Propeller fan x 2		
	Air flow rate	m ³ /min	230		320	
		L/s	3,833		5,333	
		cfm	8,121		11,299	
	Driving mechanism	Inverter-control, Direct-driven by motor				
Motor output	kW	0.92 x 1		0.92 x 2		
	External static press.	0 Pa (0 mmH ₂ O)		0 Pa (0 mmH ₂ O)		
Compressor	Type x Quantity	Inverter scroll hermetic compressor				
	Starting method	Inverter		Inverter		
	Motor output kW	10.9		12.4		
	Case heater kW	-		-		
External finish		Pre-coated galvanized steel sheets (+powder coating for -BS type) <MUNSELL 5Y 8/1 or similar>		Pre-coated galvanized steel sheets (+powder coating for -BS type) <MUNSELL 5Y 8/1 or similar>		
External dimension HxWxD	mm	1,710 (1,650 without legs) x 1,220 x 740		1,710 (1,650 without legs) x 1,750 x 740		
	in.	67-3/8 (65 without legs) x 48-1/16 x 29-3/16		67-3/8 (65 without legs) x 68-15/16 x 29-3/16		
Protection devices	High pressure protection	High pressure sensor, High pressure switch at 4.15 MPa (601 psi)		High pressure sensor, High pressure switch at 4.15 MPa (601 psi)		
	Inverter circuit (COMP./FAN)	Over-heat protection, Over-current protection		Over-heat protection, Over-current protection		
	Compressor	Over-heat protection		Over-heat protection		
	Fan motor	Over-current protection		Over-current protection		
Refrigerant	Type x original charge	R410A x 10.3 kg (23 lbs)		R410A x 11.8 kg (27 lbs)		
Net weight	kg (lbs)	246 (543)		321 (708)		
Heat exchanger		Salt-resistant cross fin & copper tube				
Pipe between unit and distributor	High pressure mm (in.)	22.2 (7/8) Brazed		22.2 (7/8) Brazed		
	Low pressure mm (in.)	28.58 (1-1/8) Brazed		28.58 (1-1/8) Brazed		
Optional parts		Outdoor Twinning kit: CMY-R200XLVBK Joint: CMY-Y102SS-G2, CMY-Y102LS-G2, CMY-R160-J1 Main BC controller: CMB-P1016V-HA1 Sub BC controller: CMB-P104, 108V-GB1, CMB-P1016V-HB1		Outdoor Twinning kit: CMY-R200XLVBK Joint: CMY-Y102SS-G2, CMY-Y102LS-G2, CMY-R160-J1 Main BC controller: CMB-P1016V-HA1 Sub BC controller: CMB-P104, 108V-GB1, CMB-P1016V-HB1		

Notes:

*1,*2 Nominal conditions

	Indoor	Outdoor	Pipe length	Level difference
Cooling	27°C DB/19°C WB (81°F DB/66°F WB)	35°C DB/24°C WB (95°F DB/75°F WB)	7.5m (24-9/16ft.)	0m (0ft.)
Heating	20°C DB(68°F DB)	7°C DB/6°C WB(45°F DB/43°F WB)	7.5m (24-9/16ft.)	0m (0ft.)

*3 -5°C DB (23°F DB) / -6°C WB (21°F WB) to 21°C DB (70°F DB) / 15.5°C WB (60°F WB) with cooling/heating mixed operation.

*4 External static pressure option is available (30Pa, 60Pa / 3.1mmH₂O, 6.1mmH₂O).

*Nominal condition *1,*2 are subject to JIS B8615-1.

*Due to continuing improvement, above specification may be subject to change without notice.

OUTDOOR UNIT R2 Series - High COP PURY-EP YLM-A1(-BS)



► Specifications

Model	PURY-EP200YLM-A (-BS)		PURY-EP250YLM-A (-BS)		PURY-EP300YLM-A (-BS)	
Power source	3-phase 4-wire 380-400-415 V 50/60 Hz		3-phase 4-wire 380-400-415 V 50/60 Hz		3-phase 4-wire 380-400-415 V 50/60 Hz	
Cooling capacity (Nominal)	*1	kW	22.4		33.5	
	*1	BTU / h	76,400		114,300	
		Power input kW	5.48		9.20	
		Current input A	9.2-8.7-8.4		15.5-14.7-14.2	
		EER kW / kW	4.08		3.64	
Temp. range of cooling	*3	Indoor W.B.	15.0~24.0°C (59~75°F)		15.0~24.0°C (59~75°F)	
		Outdoor D.B.	-5.0~46.0°C (23~115°F)		-5.0~46.0°C (23~115°F)	
Heating capacity (Nominal)	*2	kW	25.0		37.5	
	*2	BTU / h	85,300		128,000	
		Power input kW	6.41		9.97	
		Current input A	10.8-10.2-9.9		16.8-15.9-15.4	
		COP kW / kW	3.90		3.76	
Temp. range of heating	*3	Indoor D.B.	15.0~27.0°C (59~81°F)		15.0~27.0°C (59~81°F)	
		Outdoor W.B.	-20.0~15.5°C (-4~60°F)		-20.0~15.5°C (-4~60°F)	
Indoor unit connectable	Total capacity		50~150%		50~150% of outdoor unit capacity	
	Model / Quantity		P15-P250/1~20		P15-P250/1~25	
Sound pressure level (measured in anechoic room)	dB <A>		59		60	
Sound power level (measured in anechoic room)	dB <A>		82.5		83.5	
Refrigerant piping diameter	High pressure mm (in.)		15.88 (5/8) Brazed		19.05 (3/4) Brazed	
	Low pressure mm (in.)		19.05 (3/4) Brazed		22.2 (7/8) Brazed	
FAN	Type x Quantity		Propeller fan x 1		Propeller fan x 1	
	Air flow rate	m ³ /min	185		230	
		L/s	3,083		3,833	
		cfm	6,532		8,121	
	Driving mechanism		Inverter-control, Direct-driven by motor		Inverter-control, Direct-driven by motor	
	Motor output kW		0.92 x 1		0.92 x 1	
	*4 External static press.		0 Pa (0 mmH ₂ O)		0 Pa (0 mmH ₂ O)	
Compressor	Type x Quantity		Inverter scroll hermetic compressor		Inverter scroll hermetic compressor	
	Starting method		Inverter		Inverter	
	Motor output kW		5.6		6.9	
	Case heater kW		-		-	
External finish		Pre-coated galvanized steel sheets (+powder coating for -BS type) <MUNSELL 5Y 8/1 or similar>		Pre-coated galvanized steel sheets (+powder coating for -BS type) <MUNSELL 5Y 8/1 or similar>		
External dimension HxWxD	mm		1,710 (1,650 without legs) x 920 x 740		1,710 (1,650 without legs) x 920 x 740	
	in.		67-3/8 (65 without legs) x 36-1/4 x 29-3/16		67-3/8 (65 without legs) x 36-1/4 x 29-3/16	
Protection devices	High pressure protection		High pressure sensor, High pressure switch at 4.15 MPa (601 psi)		High pressure sensor, High pressure switch at 4.15 MPa (601 psi)	
	Inverter circuit (COMP./FAN)		Over-heat protection, Over-current protection		Over-heat protection, Over-current protection	
	Compressor		Over-heat protection		Over-heat protection	
	Fan motor		Over-current protection		Over-current protection	
Refrigerant	Type x original charge		R410A x 8.5 kg (19 lbs)		R410A x 8.5 kg (19 lbs)	
Net weight	kg (lbs)		218 (481)		260 (574)	
Heat exchanger			Salt-resistant cross fin & aluminium tube		Salt-resistant cross fin & aluminium tube	
Optional parts			Joint: CMY-Y102SS-G2, CMY-Y102LS-G2, CMY-R160-J1 BC controller: CMB-P104, 105, 106, 108, 1010, 1013, 1016V-G1 Main BC controller: CMB-P108, 1010, 1013, 1016V-GA1 Sub BC controller: CMB-P104, 108V-GB1, CMB-P1016V-HB1		Joint: CMY-Y102SS-G2, CMY-Y102LS-G2, CMY-R160-J1 BC controller: CMB-P104, 105, 106, 108, 1010, 1013, 1016V-G1 Main BC controller: CMB-P108, 1010, 1013, 1016V-GA1 Sub BC controller: CMB-P104, 108V-GB1, CMB-P1016V-HB1	



Notes:

*1,*2 Nominal conditions

	Indoor	Outdoor	Pipe length	Level difference
Cooling	27°C DB/19°C WB (81°F DB/66°F WB)	35°C DB/24°C WB (95°F DB/75°F WB)	7.5m (24-9/16ft.)	0m (0ft.)
Heating	20°C DB(68°F DB)	7°C DB/6°C WB(45°F DB/43°F WB)	7.5m (24-9/16ft.)	0m (0ft.)

*3 -5°C DB (23°F DB) / -6°C WB (21°F WB) to 21°C DB (70°F DB) / 15.5°C WB (60°F WB) with cooling/heating mixed operation.

*4 External static pressure option is available (30Pa, 60Pa / 3.1mmH₂O, 6.1mmH₂O).

*Nominal condition *1,*2 are subject to JIS B8615-1.

*Due to continuing improvement, above specification may be subject to change without notice.

OUTDOOR UNIT R2 Series - High COP PURY-EP YLM-A1(-BS)



► Specifications

Model	PURY-EP350YLM-A (-BS)		PURY-EP400YLM-A (-BS)		PURY-EP450YLM-A (-BS)	
Power source	3-phase 4-wire 380-400-415 V 50/60 Hz		3-phase 4-wire 380-400-415 V 50/60 Hz		3-phase 4-wire 380-400-415 V 50/60 Hz	
Cooling capacity (Nominal)	*1	kW	40.0		50.0	
	*1	BTU / h	136,500		170,600	
		Power input kW	12.57		14.83	
		Current input A	21.2-20.1-19.4		25.0-23.7-22.9	
		EER kW / kW	3.18		3.37	
Temp. range of cooling	*3	Indoor W.B.	15.0~24.0°C (59~75°F)		15.0~24.0°C (59~75°F)	
		Outdoor D.B.	-5.0~46.0°C (23~115°F)		-5.0~46.0°C (23~115°F)	
Heating capacity (Nominal)	*2	kW	45.0		56.0	
	*2	BTU / h	153,500		191,100	
		Power input kW	12.93		15.86	
		Current input A	21.8-20.7-19.9		26.7-25.4-24.5	
		COP kW / kW	3.48		3.53	
Temp. range of heating	*3	Indoor D.B.	15.0~27.0°C (59~81°F)		15.0~27.0°C (59~81°F)	
		Outdoor W.B.	-20.0~15.5°C (-4~60°F)		-20.0~15.5°C (-4~60°F)	
Indoor unit connectable	Total capacity		50~150% of outdoor unit capacity		50~150% of outdoor unit capacity	
	Model / Quantity		P15-P250/1~35		P15-P250/1~40	
Sound pressure level (measured in anechoic room)	dB <A>		62.5		62.5	
Sound power level (measured in anechoic room)	dB <A>		86		86	
Refrigerant piping diameter	High pressure mm (in.)		19.05 (3/4) Brazed		22.2 (7/8) Brazed	
	Low pressure mm (in.)		28.58 (1-1/8) Brazed		28.58 (1-1/8) Brazed	
FAN	Type x Quantity		Propeller fan x 1		Propeller fan x 2	
	Air flow rate	m ³ /min	230		320	
		L/s	3,833		5,333	
		cfm	8,121		11,299	
	Driving mechanism		Inverter-control, Direct-driven by motor		Inverter-control, Direct-driven by motor	
	Motor output kW		0.92 x 1		0.92 x 2	
	*4 External static press.		0 Pa (0 mmH ₂ O)		0 Pa (0 mmH ₂ O)	
Compressor	Type x Quantity		Inverter scroll hermetic compressor		Inverter scroll hermetic compressor	
	Starting method		Inverter		Inverter	
	Motor output kW		10.5		10.9	
	Case heater kW		-		-	
External finish		Pre-coated galvanized steel sheets (+powder coating for -BS type) <MUNSELL 5Y 8/1 or similar>		Pre-coated galvanized steel sheets (+powder coating for -BS type) <MUNSELL 5Y 8/1 or similar>		
External dimension HxWxD	mm		1,710 (1,650 without legs) x 1,220 x 740		1,710 (1,650 without legs) x 1,750 x 740	
	in.		67-3/8 (65 without legs) x 48-1/16 x 29-3/16		67-3/8 (65 without legs) x 68-15/16 x 29-3/16	
Protection devices	High pressure protection		High pressure sensor, High pressure switch at 4.15 MPa (601 psi)		High pressure sensor, High pressure switch at 4.15 MPa (601 psi)	
	Inverter circuit (COMP./FAN)		Over-heat protection, Over-current protection		Over-heat protection, Over-current protection	
	Compressor		Over-heat protection		Over-heat protection	
	Fan motor		Over-current protection		Over-current protection	
Refrigerant	Type x original charge		R410A x 9.3 kg (21 lbs)		R410A x 11.8 kg (27 lbs)	
Net weight	kg (lbs)		260 (574)		338 (746)	
Heat exchanger			Salt-resistant cross fin & aluminium tube		Salt-resistant cross fin & aluminium tube	
Optional parts			Joint: CMY-Y102SS-G2, CMY-Y102LS-G2, CMY-R160-J1 BC controller: CMB-P104, 105, 106, 108, 1010, 1013, 1016V-G1 Main BC controller: CMB-P108, 1010, 1013, 1016V-GA1 Sub BC controller: CMB-P104, 108V-GB1, CMB-P1016V-HB1		Joint: CMY-Y102SS-G2, CMY-Y102LS-G2, CMY-R160-J1 Main BC controller: CMB-P108, 1010, 1013, 1016V-GA1 Sub BC controller: CMB-P104, 108V-GB1, CMB-P1016V-HB1	



Notes:

*1,*2 Nominal conditions

	Indoor	Outdoor	Pipe length	Level difference
Cooling	27°C DB/19°C WB (81°F DB/66°F WB)	35°C DB/24°C WB (95°F DB/75°F WB)	7.5m (24-9/16ft.)	0m (0ft.)
Heating	20°C DB(68°F DB)	7°C DB/6°C WB(45°F DB/43°F WB)	7.5m (24-9/16ft.)	0m (0ft.)

*3 -5°C DB (23°F DB) / -6°C WB (21°F WB) to 21°C DB (70°F DB) / 15.5°C WB (60°F WB) with cooling/heating mixed operation.

*4 External static pressure option is available (30Pa, 60Pa / 3.1mmH₂O, 6.1mmH₂O).

*Nominal condition *1,*2 are subject to JIS B8615-1.

*Due to continuing improvement, above specification may be subject to change without notice.

OUTDOOR UNIT R2 Series - High COP PURY-EP YSLM-A1(-BS)



► Specifications

Model			PURY-EP500YSLM-A (-BS)	PURY-EP550YSLM-A (-BS)	PURY-EP600YSLM-A (-BS)			
Power source			3-phase 4-wire 380-400-415 V 50/60 Hz	3-phase 4-wire 380-400-415 V 50/60 Hz	3-phase 4-wire 380-400-415 V 50/60 Hz			
Cooling capacity (Nominal)	*1	kW	56.0	63.0	69.0			
	*1	BTU / h	191,100	215,000	235,400			
		Power input kW	14.97	17.35	19.54			
		Current input A	25.2-24.0-23.1	29.2-27.8-26.8	32.9-31.3-30.2			
		EER kW / kW	3.74	3.63	3.53			
Temp. range of cooling	*3	Indoor W.B.	15.0~24.0°C (59~75°F)	15.0~24.0°C (59~75°F)	15.0~24.0°C (59~75°F)			
		Outdoor D.B.	-5.0~46.0°C (23~115°F)	-5.0~46.0°C (23~115°F)	-5.0~46.0°C (23~115°F)			
Heating capacity (Nominal)	*2	kW	63.0	69.0	76.5			
	*2	BTU / h	215,000	235,400	261,000			
		Power input kW	16.93	18.44	20.34			
		Current input A	28.5-27.1-26.1	31.1-29.5-28.5	34.3-32.6-31.4			
		COP kW / kW	3.72	3.74	3.76			
Temp. range of heating	*3	Indoor D.B.	15.0~27.0°C (59~81°F)	15.0~27.0°C (59~81°F)	15.0~27.0°C (59~81°F)			
		Outdoor W.B.	-20.0~15.5°C (-4~60°F)	-20.0~15.5°C (-4~60°F)	-20.0~15.5°C (-4~60°F)			
Indoor unit connectable	Total capacity		50~150% of outdoor unit capacity	50~150% of outdoor unit capacity	50~150% of outdoor unit capacity			
	Model / Quantity		P15-P250/1~50	P15-P250/2~50	P15-P250/2~50			
Sound pressure level (measured in anechoic room)		dB <A>	63	64.5	65.5			
Sound power level (measured in anechoic room)		dB <A>	86.5	88	89			
Refrigerant piping diameter	High pressure	mm (in.)	22.2 (7/8) Brazed	28.58 (1-1/8) Brazed	28.58 (1-1/8) Brazed			
	Low pressure	mm (in.)	28.58 (1-1/8) Brazed	28.58 (1-1/8) Brazed	28.58 (1-1/8) Brazed			
Set Model								
Model			PURY-EP250YLM-A (-BS)	PURY-EP250YLM-A (-BS)	PURY-EP250YLM-A (-BS)	PURY-EP300YLM-A (-BS)	PURY-EP300YLM-A (-BS)	PURY-EP300YLM-A (-BS)
FAN	Type x Quantity		Propeller fan x 1	Propeller fan x 1	Propeller fan x 1	Propeller fan x 1	Propeller fan x 1	Propeller fan x 1
	Air flow rate	m ³ /min	185	185	185	230	230	230
		L/s	3,083	3,083	3,083	3,833	3,833	3,833
		cfm	6,532	6,532	6,532	8,121	8,121	8,121
	Driving mechanism		Inverter-control, Direct-driven by motor		Inverter-control, Direct-driven by motor		Inverter-control, Direct-driven by motor	
Compressor	*4	Motor output kW	0.92 x 1	0.92 x 1	0.92 x 1	0.92 x 1	0.92 x 1	
	External static press.		0 Pa (0 mmH ₂ O)	0 Pa (0 mmH ₂ O)	0 Pa (0 mmH ₂ O)	0 Pa (0 mmH ₂ O)	0 Pa (0 mmH ₂ O)	
	Starting method		Inverter	Inverter	Inverter	Inverter	Inverter	
	Motor output kW		6.9	6.9	6.9	8.1	8.1	
Case heater kW		-	-	-	-	-		
External finish			Pre-coated galvanized steel sheets (+powder coating for -BS type) <MUNSELL 5Y 8/1 or similar>		Pre-coated galvanized steel sheets (+powder coating for -BS type) <MUNSELL 5Y 8/1 or similar>		Pre-coated galvanized steel sheets (+powder coating for -BS type) <MUNSELL 5Y 8/1 or similar>	
External dimension HxWxD	mm		1,710 (1,650 without legs) x 920 x 740	1,710 (1,650 without legs) x 920 x 740	1,710 (1,650 without legs) x 920 x 740	1,710 (1,650 without legs) x 1,220 x 740	1,710 (1,650 without legs) x 1,220 x 740	
	in.		67-3/8 (65 without legs) x 36-1/4 x 29-3/16	67-3/8 (65 without legs) x 36-1/4 x 29-3/16	67-3/8 (65 without legs) x 36-1/4 x 29-3/16	67-3/8 (65 without legs) x 48-1/16 x 29-3/16	67-3/8 (65 without legs) x 48-1/16 x 29-3/16	
Protection devices	High pressure protection		High pressure sensor, High pressure switch at 4.15 MPa (601 psi)		High pressure sensor, High pressure switch at 4.15 MPa (601 psi)		High pressure sensor, High pressure switch at 4.15 MPa (601 psi)	
	Inverter circuit (COMP./FAN)		Over-heat protection, Over-current protection		Over-heat protection, Over-current protection		Over-heat protection, Over-current protection	
	Compressor		Over-heat protection Over-heat protection		Over-heat protection Over-heat protection		Over-heat protection Over-heat protection	
	Fan motor		Over-current protection		Over-current protection		Over-current protection	
Refrigerant	Type x original charge		R410A x 8.5 kg (19 lbs)	R410A x 8.5 kg (19 lbs)	R410A x 8.5 kg (19 lbs)	R410A x 9.3 kg (21 lbs)	R410A x 9.3 kg (21 lbs)	
Net weight	kg (lbs)		218 (481)	218 (481)	218 (481)	260 (574)	260 (574)	
Heat exchanger			Salt-resistant cross fin & aluminium tube		Salt-resistant cross fin & aluminium tube		Salt-resistant cross fin & aluminium tube	
Pipe between unit and distributor	High pressure	mm (in.)	19.05 (3/4) Brazed	19.05 (3/4) Brazed	19.05 (3/4) Brazed	19.05 (3/4) Brazed	19.05 (3/4)	
	Low pressure	mm (in.)	22.2 (7/8) Brazed	-	22.2 (7/8) Brazed	-	22.2 (7/8) Brazed	
Optional parts			Outdoor Twinning kit: CMY-ER100VBK-A Joint: CMY-Y102S-G2, CMY-Y102L-G2, CMY-R160-J1 Main BC controller: CMB-P108, 1010, 1013, 1016V-GA1 Sub BC controller: CMB-P104, 108V-GB1, CMB-P1016V-HB1		Outdoor Twinning kit: CMY-ER200VBK Joint: CMY-Y102SS-G2, CMY-Y102LS-G2, CMY-R160-J1 Main BC controller: CMB-P108, 1010, 1013, 1016V-GA1 Sub BC controller: CMB-P104, 108V-GB1, CMB-P1016V-HB1		Outdoor Twinning kit: CMY-ER200VBK Joint: CMY-Y102SS-G2, CMY-Y102LS-G2, CMY-R160-J1 Main BC controller: CMB-P108, 1010, 1013, 1016V-GA1 Sub BC controller: CMB-P104, 108V-GB1, CMB-P1016V-HB1	



Notes:

*1,*2 Nominal conditions

	Indoor	Outdoor	Pipe length	Level difference
Cooling	27°C DB/19°C WB (81°F DB/66°F WB)	35°C DB/24°C WB (95°F DB/75°F WB)	7.5m (24-9/16ft.)	0m (0ft.)
Heating	20°C DB(68°F DB)	7°C DB/6°C WB(45°F DB/43°F WB)	7.5m (24-9/16ft.)	0m (0ft.)

*3 -5°C DB (23°F DB) / -6°C WB (21°F WB) to 21°C DB (70°F DB) / 15.5°C WB (60°F WB) with cooling/heating mixed operation.

*4 External static pressure option is available (30Pa, 60Pa / 3.1mmH₂O, 6.1mmH₂O).

*Nominal condition *1,*2 are subject to JIS B8615-1.

*Due to continuing improvement, above specification may be subject to change without notice.

OUTDOOR UNIT R2 Series - High COP PURY-EP YSLM-A1(-BS)



► Specifications

Model	PURY-EP650YSLM-A (-BS)		PURY-EP700YSLM-A (-BS)		PURY-EP750YSLM-A (-BS)	
Power source	3-phase 4-wire 380-400-415 V 50/60 Hz		3-phase 4-wire 380-400-415 V 50/60 Hz		3-phase 4-wire 380-400-415 V 50/60 Hz	
Cooling capacity (Nominal)	*1 kW	73.0	80.0	85.0		
	*1 BTU / h	249,100	273,000	290,000		
	Power input kW	22.12	25.97	25.99		
	Current input A	37.3-35.4-34.1	43.8-41.6-40.1	43.8-41.6-40.1		
EER	kW / kW	3.30	3.08	3.27		
Temp. range of cooling	*3 Indoor W.B.	15.0~24.0°C (59~75°F)	15.0~24.0°C (59~75°F)	15.0~24.0°C (59~75°F)		
	Outdoor D.B.	-5.0~46.0°C (23~115°F)	-5.0~46.0°C (23~115°F)	-5.0~46.0°C (23~115°F)		
Heating capacity (Nominal)	*2 kW	81.5	88.0	95.0		
	*2 BTU / h	278,100	300,300	324,100		
	Power input kW	22.51	25.28	26.38		
	Current input A	38.0-36.1-34.7	42.6-40.5-39.0	44.5-42.3-40.7		
COP	kW / kW	3.62	3.48	3.60		
Temp. range of heating	*3 Indoor D.B.	15.0~27.0°C (59~81°F)	15.0~27.0°C (59~81°F)	15.0~27.0°C (59~81°F)		
	Outdoor W.B.	-20.0~15.5°C (-4~60°F)	-20.0~15.5°C (-4~60°F)	-20.0~15.5°C (-4~60°F)		
Indoor unit connectable	Total capacity	50~150% of outdoor unit capacity	50~150% of outdoor unit capacity	50~150% of outdoor unit capacity		
	Model / Quantity	P15-P250/2~50	P15-P250/2~50	P15-P250/2~50		
Sound pressure level (measured in anechoic room)	dB <A>	65.5	65.5	65.5		
Sound power level (measured in anechoic room)	dB <A>	89	89	89		
Refrigerant piping diameter	High pressure mm (in.)	28.58 (1-1/8) Brazed	28.58 (1-1/8) Brazed	28.58 (1-1/8) Brazed		
	Low pressure mm (in.)	28.58 (1-1/8) Brazed	34.93 (1-3/8) Brazed	34.93 (1-3/8) Brazed		
Set Model						
Model	PURY-EP300YLM-A (-BS)		PURY-EP350YLM-A (-BS)		PURY-EP400YLM-A (-BS)	
FAN	Type x Quantity	Propeller fan x 1	Propeller fan x 1	Propeller fan x 1	Propeller fan x 1	Propeller fan x 2
	Air flow rate	m ³ /min	230	230	230	320
		L/s	3,833	3,833	3,833	5,333
		cfm	8,121	8,121	8,121	11,299
Driving mechanism	Inverter-control, Direct-driven by motor		Inverter-control, Direct-driven by motor		Inverter-control, Direct-driven by motor	
Motor output	kW	0.92 x 1	0.92 x 1	0.92 x 1	0.92 x 1	0.92 x 2
	External static press.	0 Pa (0 mmH ₂ O)	0 Pa (0 mmH ₂ O)	0 Pa (0 mmH ₂ O)	0 Pa (0 mmH ₂ O)	0 Pa (0 mmH ₂ O)
Compressor	Type x Quantity	Inverter scroll hermetic compressor		Inverter scroll hermetic compressor		Inverter scroll hermetic compressor
	Starting method	Inverter	Inverter	Inverter	Inverter	Inverter
	Motor output kW	8.1	10.5	10.5	10.5	10.9
	Case heater kW	-	-	-	-	-
External finish	Pre-coated galvanized steel sheets (+powder coating for -BS type) <MUNSELL 5Y 8/1 or similar>		Pre-coated galvanized steel sheets (+powder coating for -BS type) <MUNSELL 5Y 8/1 or similar>		Pre-coated galvanized steel sheets (+powder coating for -BS type) <MUNSELL 5Y 8/1 or similar>	
External dimension HxWxD	mm	1,710 (1,650 without legs) x 1,220 x 740	1,710 (1,650 without legs) x 1,220 x 740	1,710 (1,650 without legs) x 1,220 x 740	1,710 (1,650 without legs) x 1,220 x 740	1,710 (1,650 without legs) x 1,750 x 740
	in.	67-3/8 (65 without legs) x 48-1/16 x 29-3/16	67-3/8 (65 without legs) x 48-1/16 x 29-3/16	67-3/8 (65 without legs) x 48-1/16 x 29-3/16	67-3/8 (65 without legs) x 48-1/16 x 29-3/16	67-3/8 (65 without legs) x 68-15/16 x 29-3/16
Protection devices	High pressure protection	High pressure sensor, High pressure switch at 4.15 MPa (601 psi)		High pressure sensor, High pressure switch at 4.15 MPa (601 psi)		High pressure sensor, High pressure switch at 4.15 MPa (601 psi)
	Inverter circuit (COMP./FAN)	Over-heat protection, Over-current protection		Over-heat protection, Over-current protection		Over-heat protection, Over-current protection
	Compressor	Over-heat protection Over-heat protection		Over-heat protection Over-heat protection		Over-heat protection Over-heat protection
	Fan motor	Over-current protection		Over-current protection		Over-current protection
Refrigerant	Type x original charge	R410A x 9.3 kg (21 lbs)	R410A x 9.3 kg (21 lbs)	R410A x 9.3 kg (21 lbs)	R410A x 9.3 kg (21 lbs)	R410A x 11.8 kg (27 lbs)
Net weight	kg (lbs)	260 (574)	260 (574)	260 (574)	260 (574)	338 (746)
Heat exchanger		Salt-resistant cross fin & aluminium tube		Salt-resistant cross fin & aluminium tube		Salt-resistant cross fin & aluminium tube
Pipe between unit and distributor	High pressure mm (in.)	19.05 (3/4) Brazed	19.05 (3/4) Brazed	19.05 (3/4) Brazed	19.05 (3/4) Brazed	22.2 (7/8) Brazed
	Low pressure mm (in.)	22.2 (7/8) Brazed	-	28.58 (1-1/8) Brazed	-	28.58 (1-1/8) Brazed
Outdoor parts		Outdoor Twinning kit: CMY-ER200VBK Joint: CMY-Y102SS-G2, CMY-Y102LS-G2, CMY-R160-J1 Main BC controller: CMB-P108, 1010, 1013, 1016V-GA1 Sub BC controller: CMB-P104, 108V-GB1, CMB-P1016V-HB1		Outdoor Twinning kit: CMY-ER200VBK Joint: CMY-Y102SS-G2, CMY-Y102LS-G2, CMY-R160-J1 Main BC controller: CMB-P1016V-HA1 Sub BC controller: CMB-P104, 108V-GB1, CMB-P1016V-HB1		Outdoor Twinning kit: CMY-ER200VBK Joint: CMY-Y102SS-G2, CMY-Y102LS-G2, CMY-R160-J1 Main BC controller: CMB-P1016V-HA1 Sub BC controller: CMB-P104, 108V-GB1, CMB-P1016V-HB1



Notes:

*1, *2 Nominal conditions

	Indoor	Outdoor	Pipe length	Level difference
Cooling	27°C DB/19°C WB (81°F DB/66°F WB)	35°C DB/24°C WB (95°F DB/75°F WB)	7.5m (24-9/16ft.)	0m (0ft.)
Heating	20°C DB(68°F DB)	7°C DB/6°C WB(45°F DB/43°F WB)	7.5m (24-9/16ft.)	0m (0ft.)

*3 -5°C DB (23°F DB) / -6°C WB (21°F WB) to 21°C DB (70°F DB) / 15.5°C WB (60°F WB) with cooling/heating mixed operation.

*4 External static pressure option is available (30Pa, 60Pa / 3.1mmH₂O, 6.1mmH₂O).

*Nominal condition *1, *2 are subject to JIS B8615-1.

*Due to continuing improvement, above specification may be subject to change without notice.

OUTDOOR UNIT

R2 Series - High COP

PURY-EP YSLM-A1(-BS)



► Specifications

Model			PURY-EP800YSLM-A (-BS)	PURY-EP850YSLM-A (-BS)	PURY-EP900YSLM-A (-BS)				
Power source			3-phase 4-wire 380-400-415 V 50/60 Hz	3-phase 4-wire 380-400-415 V 50/60 Hz	3-phase 4-wire 380-400-415 V 50/60 Hz				
Cooling capacity (Nominal)	*1	kW	90.0	96.0	101.0				
	*1	BTU / h	307,100	327,600	344,600				
		Power input kW	25.93	28.48	30.98				
		Current input A	43.7-41.5-40.0	48.0-45.6-44.0	52.2-49.6-47.8				
		EER	3.47	3.37	3.26				
Temp. range of cooling	*3	Indoor W.B.	15.0~24.0°C (59~75°F)	15.0~24.0°C (59~75°F)	15.0~24.0°C (59~75°F)				
		Outdoor D.B.	-5.0~46.0°C (23~115°F)	-5.0~46.0°C (23~115°F)	-5.0~46.0°C (23~115°F)				
Heating capacity (Nominal)	*2	kW	100.0	108.0	113.0				
	*2	BTU / h	341,200	368,500	385,600				
		Power input kW	26.80	29.75	32.01				
		Current input A	45.2-42.9-41.4	50.2-47.7-45.9	54.0-51.3-49.4				
		COP	3.73	3.63	3.53				
Temp. range of heating	*3	Indoor D.B.	15.0~27.0°C (59~81°F)	15.0~27.0°C (59~81°F)	15.0~27.0°C (59~81°F)				
		Outdoor W.B.	-20.0~15.5°C (-4~60°F)	-20.0~15.5°C (-4~60°F)	-20.0~15.5°C (-4~60°F)				
Indoor unit connectable	Total capacity		50~150% of outdoor unit capacity	50~150% of outdoor unit capacity	50~150% of outdoor unit capacity				
	Model / Quantity		P15-P250/2~50	P15-P250/2~50	P15-P250/2~50				
Sound pressure level (measured in anechoic room)		dB <A>	65.5	65.5	65.5				
Sound power level (measured in anechoic room)		dB <A>	89	89	89				
Refrigerant piping diameter	High pressure	mm (in.)	28.58 (1-1/8) Brazed	28.58 (1-1/8) Brazed	28.58 (1-1/8) Brazed				
	Low pressure	mm (in.)	34.93 (1-3/8) Brazed	41.28 (1-5/8) Brazed	41.28 (1-5/8) Brazed				
Set Model									
Model			PURY-EP400YLM-A (-BS)	PURY-EP400YLM-A (-BS)	PURY-EP400YLM-A (-BS)	PURY-EP450YLM-A (-BS)	PURY-EP450YLM-A (-BS)	PURY-EP450YLM-A (-BS)	
FAN	Type x Quantity		Propeller fan x 2	Propeller fan x 2	Propeller fan x 2	Propeller fan x 2	Propeller fan x 2	Propeller fan x 2	
	Air flow rate	m ³ /min	320	320	320	320	320	320	
		L/s	5,333	5,333	5,333	5,333	5,333	5,333	
		cfm	11,299	11,299	11,299	11,299	11,299	11,299	
	Driving mechanism		Inverter-control, Direct-driven by motor		Inverter-control, Direct-driven by motor		Inverter-control, Direct-driven by motor		
Compressor	Motor output		0.92 x 1	0.92 x 1	0.92 x 2	0.92 x 2	0.92 x 2	0.92 x 2	
	External static press.		0 Pa (0 mmH ₂ O)	0 Pa (0 mmH ₂ O)	0 Pa (0 mmH ₂ O)	0 Pa (0 mmH ₂ O)	0 Pa (0 mmH ₂ O)	0 Pa (0 mmH ₂ O)	
	Starting method		Inverter	Inverter	Inverter	Inverter	Inverter	Inverter	
	Motor output		10.9	10.9	10.9	12.4	12.4	12.4	
Case heater		-		-		-		-	
External finish			Pre-coated galvanized steel sheets (+powder coating for -BS type) <MUNSELL 5Y 8/1 or similar>		Pre-coated galvanized steel sheets (+powder coating for -BS type) <MUNSELL 5Y 8/1 or similar>		Pre-coated galvanized steel sheets (+powder coating for -BS type) <MUNSELL 5Y 8/1 or similar>		
External dimension HxWxD			mm 1,710 (1,650 without legs) x 1,750 x 740		mm 1,710 (1,650 without legs) x 1,750 x 740		mm 1,710 (1,650 without legs) x 1,750 x 740		
			in. 67-3/8 (65 without legs) x 68-15/16 x 29-3/16		in. 67-3/8 (65 without legs) x 68-15/16 x 29-3/16		in. 67-3/8 (65 without legs) x 68-15/16 x 29-3/16		
Protection devices	High pressure protection		High pressure sensor, High pressure switch at 4.15 MPa (601 psi)		High pressure sensor, High pressure switch at 4.15 MPa (601 psi)		High pressure sensor, High pressure switch at 4.15 MPa (601 psi)		
	Inverter circuit (COMP./FAN)		Over-heat protection, Over-current protection		Over-heat protection, Over-current protection		Over-heat protection, Over-current protection		
	Compressor		Over-heat protection		Over-heat protection		Over-heat protection		
	Fan motor		Over-current protection		Over-current protection		Over-current protection		
Refrigerant			Type x original charge		R410A x 11.8 kg (27 lbs)		R410A x 11.8 kg (27 lbs)		
Net weight			kg (lbs)		338 (746)		338 (746)		
Heat exchanger			Salt-resistant cross fin & aluminium tube		Salt-resistant cross fin & aluminium tube		Salt-resistant cross fin & aluminium tube		
Pipe between unit and distributor	High pressure		22.2 (7/8) Brazed		22.2 (7/8) Brazed		22.2 (7/8) Brazed		
	Low pressure		28.58 (1-1/8) Brazed		28.58 (1-1/8) Brazed		28.58 (1-1/8) Brazed		
Optional parts			Outdoor Twinning kit: CMY-ER200VBK Joint: CMY-Y102SS-G2, CMY-Y102LS-G2, CMY-R160-J1 Main BC controller: CMB-P1016V-HA1 Sub BC controller: CMB-P104, 108V-GB1, CMB-P1016V-HB1		Outdoor Twinning kit: CMY-ER200VBK Joint: CMY-Y102SS-G2, CMY-Y102LS-G2, CMY-R160-J1 Main BC controller: CMB-P1016V-HA1 Sub BC controller: CMB-P104, 108V-GB1, CMB-P1016V-HB1		Outdoor Twinning kit: CMY-ER200VBK Joint: CMY-Y102SS-G2, CMY-Y102LS-G2, CMY-R160-J1 Main BC controller: CMB-P1016V-HA1 Sub BC controller: CMB-P104, 108V-GB1, CMB-P1016V-HB1		



Notes:

*1,*2 Nominal conditions

	Indoor	Outdoor	Pipe length	Level difference
Cooling	27°C DB/19°C WB (81°F DB/66°F WB)	35°C DB/24°C WB (95°F DB/75°F WB)	7.5m (24-9/16ft.)	0m (0ft.)
Heating	20°C DB(68°F DB)	7°C DB/6°C WB(45°F DB/43°F WB)	7.5m (24-9/16ft.)	0m (0ft.)

*3 -5°C DB (23°F DB) / -6°C WB (21°F WB) to 21°C DB (70°F DB) / 15.5°C WB (60°F WB) with cooling/heating mixed operation.

*4 External static pressure option is available (30Pa, 60Pa / 3.1mmH₂O, 6.1mmH₂O).

*Nominal condition *1,*2 are subject to JIS B8615-1.

*Due to continuing improvement, above specification may be subject to change without notice.

HEAT SOURCE UNIT WR2 (Heat Recovery) Series PQRY-P YLM-A

NEW



► Specifications

Model		PQRY-P200YLM-A	PQRY-P250YLM-A	PQRY-P300YLM-A
Power source		3-phase 4-wire 380-400-415 V 50/60 Hz	3-phase 4-wire 380-400-415 V 50/60 Hz	3-phase 4-wire 380-400-415 V 50/60 Hz
Cooling capacity (Nominal)	*1 kW	22.4	28.0	33.5
	*1 kcal / h	20,000	25,000	30,000
	*1 BTU / h	76,400	95,500	114,300
	Power input kW	3.71	4.90	6.04
	Current input A	6.2-5.9-5.7	8.2-7.8-7.5	10.1-9.6-9.3
EER	kW / kW	6.03	5.71	5.54
Temp. range of cooling	Indoor W.B.	15.0~24.0°C (59~75°F)	15.0~24.0°C (59~75°F)	15.0~24.0°C (59~75°F)
	Circulating water °C	10.0~45.0°C (50~113°F)	10.0~45.0°C (50~113°F)	10.0~45.0°C (50~113°F)
Heating capacity (Nominal)	*2 kW	25.0	31.5	37.5
	*2 kcal / h	21,500	27,100	32,300
	*2 BTU / h	85,300	107,500	128,000
	Power input kW	3.97	5.08	6.25
	Current input A	6.7-6.3-6.1	8.5-8.1-7.8	10.5-10.0-9.6
COP	kW / kW	6.29	6.20	6.00
Temp. range of heating	Indoor D.B.	15.0~27.0°C (59~81°F)	15.0~27.0°C (59~81°F)	15.0~27.0°C (59~81°F)
	Circulating water °C	10.0~45.0°C (50~113°F)	10.0~45.0°C (50~113°F)	10.0~45.0°C (50~113°F)
Indoor unit connectable	Total capacity	50~150% of heat source unit capacity	50~150% of heat source unit capacity	50~150% of heat source unit capacity
	Model / Quantity	P15~P250/1~20	P15~P250/1~25	P15~P250/1~30
Sound pressure level (measured in anechoic room)	dB <A>	46	48	54
Refrigerant piping diameter	High pressure mm (in.)	15.88 (5/8) Brazed	19.05 (3/4) Brazed	19.05 (3/4) Brazed
	Low pressure mm (in.)	19.05 (3/4) Brazed	22.2 (7/8) Brazed	22.2 (7/8) Brazed
Circulating water	Water flow rate	m ³ / h	5.76	5.76
		L/min	96	96
		cfm	3.4	3.4
	Pressure drop	kPa	24	24
	Operating volume range	m ³ / h	3.0 ~ 7.2	3.0 ~ 7.2
Compressor	Type	Inverter scroll hermetic compressor	Inverter scroll hermetic compressor	Inverter scroll hermetic compressor
	Starting method	Inverter	Inverter	Inverter
	Motor output kW	4.8	6.2	7.7
	Case heater	kW	—	—
External finish		Galvanized steel sheets	Galvanized steel sheets	Galvanized steel sheets
External dimension HxWxD	mm	1,100 x 880 x 550	1,100 x 880 x 550	1,100 x 880 x 550
	in.	43-5/16 x 34-11/16 x 21-11/16	43-5/16 x 34-11/16 x 21-11/16	43-5/16 x 34-11/16 x 21-11/16
Protection devices	High pressure protection	High pressure sensor, High pressure switch at 4.15 MPa (601 psi)	High pressure sensor, High pressure switch at 4.15 MPa (601 psi)	High pressure sensor, High pressure switch at 4.15 MPa (601 psi)
	Inverter circuit (COMP.)	Over-heat protection, Over-current protection	Over-heat protection, Over-current protection	Over-heat protection, Over-current protection
	Compressor	Over-heat protection	Over-heat protection	Over-heat protection
Refrigerant	Type x original charge	R410A x 5.0 kg (12 lbs)	R410A x 5.0 kg (12 lbs)	R410A x 5.0 kg (12 lbs)
Net weight	kg (lbs)	172 (380)	172 (380)	172 (380)
Heat exchanger			plate type	plate type
	Water volume in plate	L	5.0	5.0
	Water pressure Max.	MPa	2.0	2.0
Optional parts	Joint: CMY-Y102SSLS-G2, CMY-R160-J1 BC controller: CMB-P104, 105, 106, 108, 1010, 1013, 1016V-G1 Main BC controller: CMB-P108, 1010, 1013, 1016V-GA1 Sub BC controller: CMB-P104, 108V-GB1, CMB-P1016V-HB1		Joint: CMY-Y102SSLS-G2, CMY-R160-J1 BC controller: CMB-P104, 105, 106, 108, 1010, 1013, 1016V-G1 Main BC controller: CMB-P108, 1010, 1013, 1016V-GA1 Sub BC controller: CMB-P104, 108V-GB1, CMB-P1016V-HB1	Joint: CMY-Y102SSLS-G2, CMY-R160-J1 BC controller: CMB-P104, 105, 106, 108, 1010, 1013, 1016V-G1 Main BC controller: CMB-P108, 1010, 1013, 1016V-GA1 Sub BC controller: CMB-P104, 108V-GB1, CMB-P1016V-HB1

Notes:

*1,*2 Nominal conditions

	Indoor	Water temperature	Pipe length	Level difference
Cooling	27°C D.B./19°C W.B. (81°F D.B./66°F W.B.)	30°C (86°F)	7.5m (24-9/16ft.)	0m (0ft.)
Heating	20°C D.B. (68°F D.B.)	20°C (68°F)		

*The ambient temperature of the heat source unit needs to be kept below 40°C D.B.

*The ambient relative humidity of the heat source unit needs to be kept below 80%.

*The heat source unit should not be installed at outdoor.

*Be sure to mount a strainer (more than 50 meshes) at the water inlet piping of the unit.

*Be sure to provide interlocking for the unit operation and water circuit.

*Nominal condition *1,*2 are subject to JIS B8615-2.

*Due to continuing improvement, above specification may be subject to change without notice.

Outdoor Unit

HEAT SOURCE UNIT WR2 (Heat Recovery) Series PQRY-P YLM-A

NEW



► Specifications

Model		PQRY-P350YLM-A	PQRY-P400YLM-A	PQRY-P450YLM-A	
Power source		3-phase 4-wire 380-400-415 V 50/60 Hz	3-phase 4-wire 380-400-415 V 50/60 Hz	3-phase 4-wire 380-400-415 V 50/60 Hz	
Cooling capacity (Nominal)	*1	kW	40.0	45.0	
		kcal / h	35,000	40,000	
	*1	BTU / h	136,500	153,500	
		Power input	kW	7.14	8.03
		Current input	A	12.0-11.4-11.0	13.5-12.8-12.4
	EER	kW / kW	5.60	5.60	
Temp. range of cooling	Indoor	W.B.	15.0~24.0°C (59~75°F)	15.0~24.0°C (59~75°F)	
	Circulating water	°C	10.0~45.0°C (50~113°F)	10.0~45.0°C (50~113°F)	
Heating capacity (Nominal)	*2	kW	45.0	50.0	
		kcal / h	40,000	45,000	
	*2	BTU / h	153,500	170,600	
		Power input	kW	7.53	8.37
		Current input	A	12.7-12.0-11.6	14.1-13.4-12.9
	COP	kW / kW	5.97	5.97	
Temp. range of heating	Indoor	D.B.	15.0~27.0°C (59~81°F)	15.0~27.0°C (59~81°F)	
	Circulating water	°C	10.0~45.0°C (50~113°F)	10.0~45.0°C (50~113°F)	
Indoor unit connectable	Total capacity	50~150% of heat source unit capacity			
	Model / Quantity	P15~P250/1~35	P15~P250/1~40	P15~P250/1~45	
Sound pressure level (measured in anechoic room)	dB <A>	52	52	54	
Refrigerant piping diameter	High pressure	22.2 (7/8) Brazed			
	Low pressure	28.58 (1-1/8) Brazed			
Circulating water	Water flow rate	m ³ / h	7.20	7.20	
		L/min	120	120	
		cfm	4.2	4.2	
	Pressure drop	kPa	44	44	
	Operating volume range	m ³ / h	4.5 ~ 11.6	4.5 ~ 11.6	4.5 ~ 11.6
Compressor	Type	Inverter scroll hermetic compressor			
	Starting method	Inverter			
	Motor output	kW	9.5	10.7	
	Case heater	kW	—	—	
External finish		Galvanized steel sheets			
External dimension HxWxD	mm	1,450 x 880 x 550			
	in.	57-1/8 x 34-11/16 x 21-11/16			
Protection devices	High pressure protection	High pressure sensor, High pressure switch at 4.15 MPa (601 psi)			
	Inverter circuit (COMP.)	Over-heat protection, Over-current protection			
	Compressor	Over-heat protection			
Refrigerant	Type x original charge	R410A x 6.0 kg (14 lbs)			
Net weight	kg (lbs)	216 (477)			
Heat exchanger	plate type				
	Water volume in plate	L	5.0	5.0	
	Water pressure Max.	MPa	2.0	2.0	
Optional parts		Joint: CMY-Y102SS/SLS-G2, CMY-R160-J1 BC controller: CMB-P104, 105, 106, 108, 1010, 1013, 1016V-G1 Main BC controller: CMB-P108, 1010, 1013, 1016V-GA1 Sub BC controller: CMB-P104, 108V-GB1, CMB-P1016V-HB1	Joint: CMY-Y102SS/SLS-G2, CMY-R160-J1 Main BC controller: CMB-P108, 1010, 1013, 1016V-GA1 Sub BC controller: CMB-P104, 108V-GB1, CMB-P1016V-HB1	Joint: CMY-Y102SS/SLS-G2, CMY-R160-J1 Main BC controller: CMB-P108, 1010, 1013, 1016V-GA1 Sub BC controller: CMB-P104, 108V-GB1, CMB-P1016V-HB1	

Notes:

*1,*2 Nominal conditions

	Indoor	Water temperature	Pipe length	Level difference
Cooling	27°C D.B./19°C W.B. (81°F D.B./66°F W.B.)	30°C (86°F)	7.5m (24-9/16ft.)	0m (0ft.)
Heating	20°C D.B. (68°F D.B.)	20°C (68°F)		

*The ambient temperature of the heat source unit needs to be kept below 40°C D.B.

*The ambient relative humidity of the heat source unit needs to be kept below 80%.

*The heat source unit should not be installed at outdoor.

*Be sure to mount a strainer (more than 50 meshes) at the water inlet piping of the unit.

*Be sure to provide interlocking for the unit operation and water circuit.

*Nominal condition *1,*2 are subject to JIS B8615-2.

*Due to continuing improvement, above specification may be subject to change without notice.

Outdoor Unit

HEAT SOURCE UNIT WR2 (Heat Recovery) Series PQRY-P YLM-A

NEW



► Specifications

Model	PQRY-P500YLM-A		PQRY-P550YLM-A		PQRY-P600YLM-A	
Power source	3-phase 4-wire 380-400-415 V 50/60 Hz		3-phase 4-wire 380-400-415 V 50/60 Hz		3-phase 4-wire 380-400-415 V 50/60 Hz	
Cooling capacity (Nominal)	*1	kW	56.0	63.0	69.0	
		kcal / h	50,000	55,000	60,000	
	*1	BTU / h	191,100	215,000	235,400	
		Power input	kW	11.17	12.54	14.49
		Current input	A	18.8-17.9-17.2	21.1-20.1-19.3	24.4-23.2-22.3
	EER	kW / kW	5.01	5.02	4.76	
Temp. range of cooling	Indoor	W.B.	15.0~24.0°C (59~75°F)	15.0~24.0°C (59~75°F)	15.0~24.0°C (59~75°F)	
	Circulating water	°C	10.0~45.0°C (50~113°F)	10.0~45.0°C (50~113°F)	10.0~45.0°C (50~113°F)	
Heating capacity (Nominal)	*2	kW	63.0	69.0	76.5	
		kcal / h	55,000	60,000	65,800	
	*2	BTU / h	215,000	235,400	261,000	
		Power input	kW	11.43	12.27	14.51
		Current input	A	19.2-18.3-17.6	20.7-19.6-18.9	24.4-23.2-22.4
	COP	kW / kW	5.51	5.62	5.27	
Temp. range of heating	Indoor	D.B.	15.0~27.0°C (59~81°F)	15.0~27.0°C (59~81°F)	15.0~27.0°C (59~81°F)	
	Circulating water	°C	10.0~45.0°C (50~113°F)	10.0~45.0°C (50~113°F)	10.0~45.0°C (50~113°F)	
Indoor unit connectable	Total capacity		50~150% of heat source unit capacity	50~150% of heat source unit capacity	50~150% of heat source unit capacity	
	Model / Quantity		P15~P250/1~50	P15~P250/2~50	P15~P250/2~50	
Sound pressure level (measured in anechoic room)		dB <A>	54	56.5	56.5	
Refrigerant piping diameter	High pressure	mm (in.)	22.2 (7/8) Brazed	22.2 (7/8) Brazed (1-1/8 (28.58) Brazed for the part that exceeds 65 m)	22.2 (7/8) Brazed (1-1/8 (28.58) Brazed for the part that exceeds 65 m)	
	Low pressure	mm (in.)	28.58 (1-1/8) Brazed	28.58 (1-1/8) Brazed	34.93 (1-3/8) Brazed	
Circulating water	Water flow rate	m ³ / h	7.20	11.52	11.52	
		L/min	120	192	192	
		cfm	4.2	6.8	6.8	
	Pressure drop	kPa	44	45	45	
	Operating volume range	m ³ / h	4.5 ~ 11.6	6.0 ~ 14.4	6.0 ~ 14.4	
Compressor	Type		Inverter scroll hermetic compressor	Inverter scroll hermetic compressor	Inverter scroll hermetic compressor	
	Starting method		Inverter	Inverter	Inverter	
	Motor output	kW	13.0	15.0	16.1	
	Case heater	kW	—	0.045 (240 V)	0.045 (240 V)	
External finish			Galvanized steel sheets	Galvanized steel sheets	Galvanized steel sheets	
External dimension HxWxD	mm		1,450 x 880 x 550	1,450 x 880 x 550	1,450 x 880 x 550	
		in.	57-1/8 x 34-11/16 x 21-11/16	57-1/8 x 34-11/16 x 21-11/16	57-1/8 x 34-11/16 x 21-11/16	
Protection devices	High pressure protection		High pressure sensor, High pressure switch at 4.15 MPa (601 psi)	High pressure sensor, High pressure switch at 4.15 MPa (601 psi)	High pressure sensor, High pressure switch at 4.15 MPa (601 psi)	
	Inverter circuit (COMP.)		Over-heat protection, Over-current protection	Over-heat protection, Over-current protection	Over-heat protection, Over-current protection	
	Compressor		Over-heat protection	Over-heat protection	Over-heat protection	
Refrigerant	Type x original charge		R410A x 6.0 kg (14 lbs)	R410A x 11.7 kg (26 lbs)	R410A x 11.7 kg (26 lbs)	
Net weight	kg (lbs)		216 (477)	246 (543)	246 (543)	
Heat exchanger			plate type	plate type	plate type	
	Water volume in plate	L	5.0	10.0	10.0	
	Water pressure Max.	MPa	2.0	2.0	2.0	
Optional parts			Joint: CMY-Y102SS/LS-G2, CMY-R160-J1 Main BC controller: CMB-P108, 1010, 1013, 1016V-GA1 Sub BC controller: CMB-P104, 108V-GB1, CMB-P1016V-HB1	Joint: CMY-Y102SS/LS-G2, CMY-R160-J1 Main BC controller: CMB-P108, 1010, 1013, 1016V-GA1 Sub BC controller: CMB-P104, 108V-GB1, CMB-P1016V-HB1	Joint: CMY-Y102SS/LS-G2, CMY-R160-J1 Main BC controller: CMB-P108, 1010, 1013, 1016V-GA1 Sub BC controller: CMB-P104, 108V-GB1, CMB-P1016V-HB1	

Notes:

*1,*2 Nominal conditions

	Indoor	Water temperature	Pipe length	Level difference
Cooling	27°C D.B./19°C W.B. (81°F D.B./66°F W.B.)	30°C (86°F)	7.5m (24-9/16ft.)	0m (0ft.)
Heating	20°C D.B. (68°F D.B.)	20°C (68°F)		

*The ambient temperature of the heat source unit needs to be kept below 40°C D.B.

*The ambient relative humidity of the heat source unit needs to be kept below 80%.

*The heat source unit should not be installed at outdoor.

*Be sure to mount a strainer (more than 50 meshes) at the water inlet piping of the unit.

*Be sure to provide interlocking for the unit operation and water circuit.

*Nominal condition *1,*2 are subject to JIS B8615-2.

*Due to continuing improvement, above specification may be subject to change without notice.

Outdoor Unit

HEAT SOURCE UNIT WR2 (Heat Recovery) Series PQRY-P YSLM-A

NEW



► Specifications

Model		PQRY-P700YSLM-A		
Power source		3-phase 4-wire 380-400-415 V 50/60 Hz		
Cooling capacity (Nominal)	*1	kW	80.0	
		kcal / h	68,800	
	*1	BTU / h	273,000	
		Power input	kW	14.73
		Current input	A	24.8-23.6-22.7
	EER	kW / kW	5.43	
Temp. range of cooling	Indoor	W.B.	15.0~24.0°C (59~75°F)	
	Circulating water	°C	10.0~45.0°C (50~113°F)	
Heating capacity (Nominal)	*2	kW	88.0	
		kcal / h	75,700	
	*2	BTU / h	300,300	
		Power input	kW	14.73
		Current input	A	24.8-23.6-22.7
	COP	kW / kW	5.97	
Temp. range of heating	Indoor	D.B.	15.0~27.0°C (59~81°F)	
	Circulating water	°C	10.0~45.0°C (50~113°F)	
Indoor unit connectable	Total capacity	50~150% of heat source unit capacity		
	Model / Quantity	P15~P250/2~50		
Sound pressure level (measured in anechoic room)		dB <A>	55	
Refrigerant piping diameter	High pressure	mm (in.)	28.58 (1-1/8) Brazed	
	Low pressure	mm (in.)	34.93 (1-3/8) Brazed	

Set Model

Model		PQRY-P350YLM-A		PQRY-P350YLM-A	
Circulating water	Water flow rate	m ³ / h	7.20 + 7.20		
		L/min	120 + 120		
		cfm	4.2 + 4.2		
	Pressure drop	kPa	44	44	
Operating volume range	m ³ / h	4.5 + 4.5 ~ 11.6 + 11.6			
Compressor	Type	Inverter scroll hermetic compressor			
	Starting method	Inverter		Inverter	
	Motor output	kW	9.5	9.5	
	Case heater	kW	—	—	
External finish	Galvanized steel sheets				
External dimension HxWxD	mm	1,450 x 880 x 550		1,450 x 880 x 550	
		in.		57-1/8 x 34-11/16 x 21-11/16	
Protection devices	High pressure protection	High pressure sensor, High pressure switch at 4.15 MPa (601 psi)			
	Inverter circuit (COMP.)	Over-heat protection, Over-current protection			
	Compressor	Over-heat protection		Over-heat protection	
Refrigerant	Type x original charge	R410A x 6.0 kg (14 lbs)	R410A x 6.0 kg (14 lbs)		
Net weight	kg (lbs)	216 (477)	216 (477)		
Heat exchanger			plate type	plate type	
	Water volume in plate	L	5.0	5.0	
	Water pressure Max.	MPa	2.0	2.0	
Optional parts	Heat Source Twinning kit: CMY-Q200CBK Joint: CMY-Y102SS/LS-G2, CMY-R160-J1 Main BC controller: CMB-P1016V-HA1 Sub BC controller: CMB-P104, 108V-GB1, CMB-P1016V-HB1				

Notes:

*1,*2 Nominal conditions

	Indoor	Water temperature	Pipe length	Level difference
Cooling	27°C D.B./19°C W.B. (81°F D.B./66°F W.B.)	30°C (86°F)	7.5m (24-9/16ft.)	0m (0ft.)
Heating	20°C D.B. (68°F D.B.)	20°C (68°F)		

*The ambient temperature of the heat source unit needs to be kept below 40°C D.B.

*The ambient relative humidity of the heat source unit needs to be kept below 80%.

*The heat source unit should not be installed at outdoor.

*Be sure to mount a strainer (more than 50 meshes) at the water inlet piping of the unit.

*Be sure to provide interlocking for the unit operation and water circuit.

*Nominal condition *1,*2 are subject to JIS B8615-2.

*Due to continuing improvement, above specification may be subject to change without notice.

HEAT SOURCE UNIT WR2 (Heat Recovery) Series PQRY-P YSLM-A

NEW



► Specifications

Model		PQRY-P750YSLM-A		PQRY-P800YSLM-A						
Power source		3-phase 4-wire 380-400-415 V 50/60 Hz		3-phase 4-wire 380-400-415 V 50/60 Hz						
Cooling capacity (Nominal)	*1	kW	85.0	90.0						
		kcal / h	73,100	77,400						
	*1	BTU / h	290,000	307,100						
		Power input	kW	15.64	16.57					
		Current input	A	26.4-25.0-24.1	27.9-26.5-25.6					
	EER	kW / kW	5.43	5.43						
Temp. range of cooling	Indoor	W.B.	15.0~24.0°C (59~75°F)	15.0~24.0°C (59~75°F)						
	Circulating water	°C	10.0~45.0°C (50~113°F)	10.0~45.0°C (50~113°F)						
Heating capacity (Nominal)	*2	kW	95.0	100.0						
		kcal / h	81,700	86,000						
	*2	BTU / h	324,100	341,200						
		Power input	kW	15.90	16.75					
		Current input	A	26.8-25.4-24.5	28.2-26.8-25.8					
	COP	kW / kW	5.97	5.97						
Temp. range of heating	Indoor	D.B.	15.0~27.0°C (59~81°F)	15.0~27.0°C (59~81°F)						
	Circulating water	°C	10.0~45.0°C (50~113°F)	10.0~45.0°C (50~113°F)						
Indoor unit connectable	Total capacity	50~150% of heat source unit capacity		50~150% of heat source unit capacity						
	Model / Quantity	P15~P250/2~50		P15~P250/2~50						
Sound pressure level (measured in anechoic room)	dB <A>	55		55						
Refrigerant piping diameter	High pressure	mm (in.)	28.58 (1-1/8) Brazed	28.58 (1-1/8) Brazed						
	Low pressure	mm (in.)	34.93 (1-3/8) Brazed	34.93 (1-3/8) Brazed						
Set Model										
Model		PQRY-P400YLM-A		PQRY-P350YLM-A		PQRY-P400YLM-A		PQRY-P400YLM-A		
Circulating water	Water flow rate	m ³ / h	7.20 + 7.20		7.20 + 7.20					
		L/min	120 + 120		120 + 120					
		cfm	4.2 + 4.2		4.2 + 4.2					
	Pressure drop	kPa	44	44	44	44				
Operating volume range	m ³ / h	4.5 + 4.5 ~ 11.6 + 11.6				4.5 + 4.5 ~ 11.6 + 11.6				
Compressor	Type	Inverter scroll hermetic compressor				Inverter scroll hermetic compressor				
	Starting method	Inverter		Inverter		Inverter		Inverter		
	Motor output	10.7		9.5		10.7		10.7		
	Case heater	-		-		-		-		
External finish	Galvanized steel sheets		Galvanized steel sheets		Galvanized steel sheets		Galvanized steel sheets			
External dimension HxWxD	mm	1,450 x 880 x 550		1,450 x 880 x 550		1,450 x 880 x 550		1,450 x 880 x 550		
	in.	57-1/8 x 34-11/16 x 21-11/16		57-1/8 x 34-11/16 x 21-11/16		57-1/8 x 34-11/16 x 21-11/16		57-1/8 x 34-11/16 x 21-11/16		
Protection devices	High pressure protection	High pressure sensor, High pressure switch at 4.15 MPa (601 psi)				High pressure sensor, High pressure switch at 4.15 MPa (601 psi)				
	Inverter circuit (COMP.)	Over-heat protection, Over-current protection				Over-heat protection, Over-current protection				
	Compressor	Over-heat protection		Over-heat protection		Over-heat protection		Over-heat protection		
Refrigerant	Type x original charge	R410A x 6.0 kg (14 lbs)		R410A x 6.0 kg (14 lbs)		R410A x 6.0 kg (14 lbs)		R410A x 6.0 kg (14 lbs)		
Net weight	kg (lbs)	216 (477)		216 (477)		216 (477)		216 (477)		
Heat exchanger			plate type		plate type		plate type		plate type	
	Water volume in plate	L	5.0		5.0		5.0		5.0	
	Water pressure Max.	MPa	2.0		2.0		2.0		2.0	
Optional parts	Heat Source Twinning kit: CMY-Q200CBK Joint: CMY-Y102SS/LS-G2, CMY-R160-J1 Main BC controller: CMB-P1016V-HA1 Sub BC controller: CMB-P104, 108V-GB1, CMB-P1016V-HB1				Heat Source Twinning kit: CMY-Q200CBK Joint: CMY-Y102SS/LS-G2, CMY-R160-J1 Main BC controller: CMB-P1016V-HA1 Sub BC controller: CMB-P104, 108V-GB1, CMB-P1016V-HB1					

Notes:

*1,*2 Nominal conditions

	Indoor	Water temperature	Pipe length	Level difference
Cooling	27°C D.B./19°C W.B. (81°F D.B./66°F W.B.)	30°C (86°F)	7.5m (24-9/16ft.)	0m (0ft.)
Heating	20°C D.B. (68°F D.B.)	20°C (68°F)		

*The ambient temperature of the heat source unit needs to be kept below 40°C D.B.

*The ambient relative humidity of the heat source unit needs to be kept below 80%.

*The heat source unit should not be installed at outdoor.

*Be sure to mount a strainer (more than 50 meshes) at the water inlet piping of the unit.

*Be sure to provide interlocking for the unit operation and water circuit.

*Nominal condition *1,*2 are subject to JIS B8615-2.

*Due to continuing improvement, above specification may be subject to change without notice.

Outdoor Unit

HEAT SOURCE UNIT WR2 (Heat Recovery) Series PQRY-P YSLM-A

NEW



► Specifications

Model		PQRY-P850YSLM-A		PQRY-P900YSLM-A		
Power source		3-phase 4-wire 380-400-415 V 50/60 Hz		3-phase 4-wire 380-400-415 V 50/60 Hz		
Cooling capacity (Nominal)	*1	kW	96.0	101.0		
		kcal / h	82,600	86,900		
	*1	BTU / h	327,600	344,600		
		Power input kW	18.03	19.38		
		Current input A	30.4-28.9-27.8	32.7-31.0-29.9		
	EER	kW / kW	5.32	5.21		
Temp. range of cooling	Indoor	W.B.	15.0~24.0°C (59~75°F)	15.0~24.0°C (59~75°F)		
	Circulating water	°C	10.0~45.0°C (50~113°F)	10.0~45.0°C (50~113°F)		
Heating capacity (Nominal)	*2	kW	108.0	113.0		
		kcal / h	92,900	97,200		
	*2	BTU / h	368,500	385,600		
		Power input kW	18.49	19.74		
		Current input A	31.2-29.6-28.5	33.3-31.6-30.5		
	COP	kW / kW	5.84	5.72		
Temp. range of heating	Indoor	D.B.	15.0~27.0°C (59~81°F)	15.0~27.0°C (59~81°F)		
	Circulating water	°C	10.0~45.0°C (50~113°F)	10.0~45.0°C (50~113°F)		
Indoor unit connectable	Total capacity	50~150% of heat source unit capacity		50~150% of heat source unit capacity		
	Model / Quantity	P15~P250/2~50		P15~P250/2~50		
Sound pressure level (measured in anechoic room)	dB <A>	56		57		
Refrigerant piping diameter	High pressure	mm (in.)	28.58 (1-1/8) Brazed	28.58 (1-1/8) Brazed		
	Low pressure	mm (in.)	41.28 (1-5/8) Brazed	41.28 (1-5/8) Brazed		
Set Model						
Model		PQRY-P450YLM-A		PQRY-P400YLM-A		
Circulating water	Water flow rate	m ³ / h	7.20 + 7.20	7.20 + 7.20		
		L/min	120 + 120	120 + 120		
		cfm	4.2 + 4.2	4.2 + 4.2		
	Pressure drop	kPa	44	44	44	44
	Operating volume range	m ³ / h	4.5 + 4.5 ~ 11.6 + 11.6		4.5 + 4.5 ~ 11.6 + 11.6	
Compressor	Type	Inverter scroll hermetic compressor		Inverter scroll hermetic compressor		
	Starting method	Inverter	Inverter	Inverter	Inverter	
	Motor output	kW	11.6	10.7	11.6	11.6
	Case heater	kW	-	-	-	-
External finish		Galvanized steel sheets	Galvanized steel sheets	Galvanized steel sheets	Galvanized steel sheets	
External dimension HxWxD	mm	1,450 x 880 x 550	1,450 x 880 x 550	1,450 x 880 x 550	1,450 x 880 x 550	
	in.	57-1/8 x 34-11/16 x 21-11/16	57-1/8 x 34-11/16 x 21-11/16	57-1/8 x 34-11/16 x 21-11/16	57-1/8 x 34-11/16 x 21-11/16	
Protection devices	High pressure protection	High pressure sensor, High pressure switch at 4.15 MPa (601 psi)		High pressure sensor, High pressure switch at 4.15 MPa (601 psi)		
	Inverter circuit (COMP.)	Over-heat protection, Over-current protection		Over-heat protection, Over-current protection		
	Compressor	Over-heat protection	Over-heat protection	Over-heat protection	Over-heat protection	
Refrigerant	Type x original charge	R410A x 6.0 kg (14 lbs)	R410A x 6.0 kg (14 lbs)	R410A x 6.0 kg (14 lbs)	R410A x 6.0 kg (14 lbs)	
Net weight	kg (lbs)	216 (477)	216 (477)	216 (477)	216 (477)	
Heat exchanger			plate type	plate type	plate type	plate type
	Water volume in plate	L	5.0	5.0	5.0	5.0
	Water pressure Max.	MPa	2.0	2.0	2.0	2.0
Optional parts			Heat Source Twinning kit: CMY-Q200CBK Joint: CMY-Y102SS/LS-G2, CMY-R160-J1 Main BC controller: CMB-P1016V-HA1 Sub BC controller: CMB-P104, 108V-GB1, CMB-P1016V-HB1	Heat Source Twinning kit: CMY-Q200CBK Joint: CMY-Y102SS/LS-G2, CMY-R160-J1 Main BC controller: CMB-P1016V-HA1 Sub BC controller: CMB-P104, 108V-GB1, CMB-P1016V-HB1		

Notes:

*1,*2 Nominal conditions

	Indoor	Water temperature	Pipe length	Level difference
Cooling	27°C D.B./19°C W.B. (81°F D.B./66°F W.B.)	30°C (86°F)	7.5m (24-9/16ft.)	0m (0ft.)
Heating	20°C D.B. (68°F D.B.)	20°C (68°F)		

*The ambient temperature of the heat source unit needs to be kept below 40°C D.B.

*The ambient relative humidity of the heat source unit needs to be kept below 80%.

*The heat source unit should not be installed at outdoor.

*Be sure to mount a strainer (more than 50 meshes) at the water inlet piping of the unit.

*Be sure to provide interlocking for the unit operation and water circuit.

*Nominal condition *1,*2 are subject to JIS B8615-2.

*Due to continuing improvement, above specification may be subject to change without notice.















Outdoor Unit

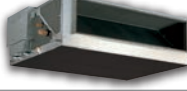

I ndoor Unit

- Ceiling cassette type 4-way airflow
- Ceiling cassette type 2-way airflow
- Ceiling cassette type 1-way airflow
- Ceiling concealed type
- Fresh Air Intake type
- Ceiling suspended type
- Wall mounted type
- Wall mounted type - Designer Series with external LEV Kit
- Floor standing exposed
- Floor mounted concealed type
- BC Controller
- Air to Water unit
-  Logsnay
- Air Handling Unit Controller
- OA Processing Units

Wide Selection of Indoor Units

Type		Model name	Model	P15	P20	P25
Ceiling Cassette	4-way air flow	PLFY-P VBM-E Page88 - Page89				
		PLFY-P VFM-E Page90 - Page91				
	2-way air flow	PLFY-P VLMD-E Page92 - Page93				
	1-way air flow	PMFY-P VBM-E Page94 - Page95				
Ceiling Concealed		PEFY-P VMS1(L)-E Page96 - Page97				
		PEFY-P VMA(L)-E Page98 - Page99				
		PEFY-P VMH(S)-E Page100 - Page101				
	Fresh Air Intake	PEFY-P VMH-E-F Page102 - Page103				
Ceiling Suspended		PCFY-P VKM-E Page104 - Page105				
Wall Mounted		PKFY-P VBM-E Page106 - Page107				
		PKFY-P VHM-E Page106 - Page107				
		PKFY-P VKM-E Page106 - Page107				
		MSZ-EF Designer Series Page108 - Page109				
Floor Standing/ Floor Mounted Concealed		PFFY-P VKM-E2 Page110 - Page111				
		PFFY-P VLEM-E Page112 - Page113				
		PFFY-P VLRM-E PFFY-P VLRMM-E Page114 - Page115				

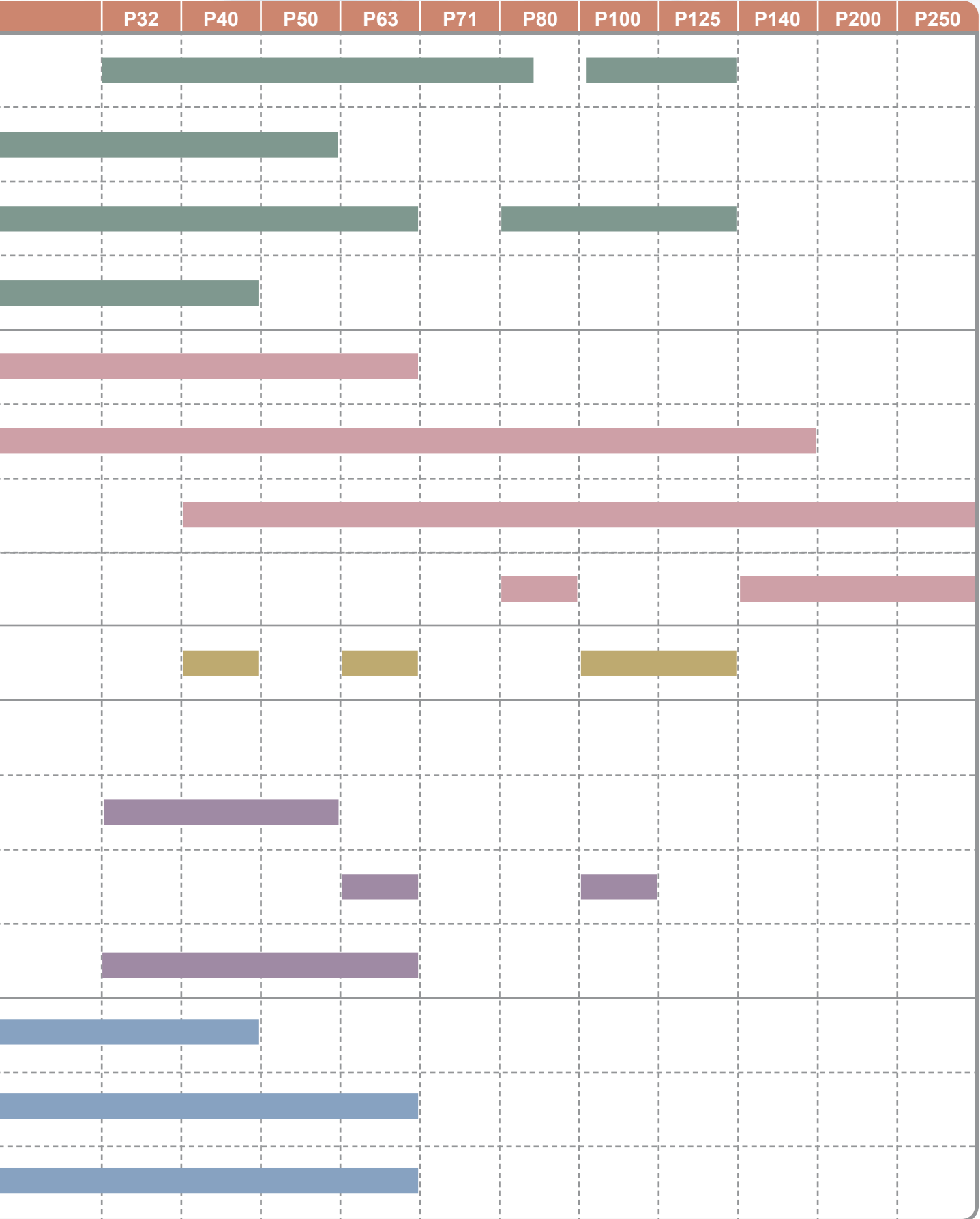

INDOOR UNIT

Ceiling cassette type

4-way airflow

PLFY-P VBM-E *i-see Sensor*



The new 4-way cassette VBM offers 72 different airflow patterns, making it ideal for applications with ceilings up to 4.2 m (13-13/16ft) in height.



Automatic Air Speed Adjustment

Auto-Fan speed mode enables fast, effective operation during start-up.

The Auto-Fan speed mode is an additional fan speed setting to the usual four steps (Low, Mid1, Mid2 and High). Auto-Fan speed mode ensures fast, effective operation on start-up by increasing the airflow speed initially, then reducing the airflow once set temperature is reached.

Controls the four fan speed modes automatically

Low → Mid1 → Mid2 → High → Auto

* When using a wireless remote controller, initial settings are required.

Draft-less Air Distribution

Horizontal airflow mode can be used to avoid drafts and discomfort to occupants. By directing the airflow horizontally, the unit creates a draft-free environment even at higher fan speeds.

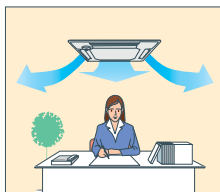

IT terminal

IT terminal is available. For details, contact your local distributor.

Indoor Unit

Wide Air Flow

In Wide Airflow mode, discharged air can reach a wider area than conventional models, while fan speed decreases by 20% thanks to the units uniquely shaped air outlet.



72 patterns of airflow to accommodate any room layout are available. **First in the industry**

*On the commercial air conditioners (According to the survey by Mitsubishi Electric)

The number of outlets can be set to 4, 3, or 2. Flexible airflow is available by fixing the up-down airflow direction of the outlet with a wired remote controller (or manually).

72 airflow patterns

4-, 3-, or 2- way outlet selection*

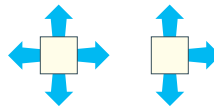

* Optional parts air outlet shutter plate (PLFY-P VBM-E ONLY) is required for 2 or 3 way outlet selection.

Setting the air direction for each outlet with wired remote controller

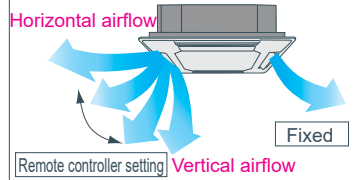

Optional "i-See" Sensor

The PLY-P VBM Cassette series can be fitted with an optional "i-See" Sensor (PAC-SA1ME-E). The i-See sensor seeks out and corrects temperature disparities within the room to ensure precise, even comfort.

Prevents overcooling/overheating, and improves comfort/energy-efficiency

Without i-see sensor: preset temperature at 23°C

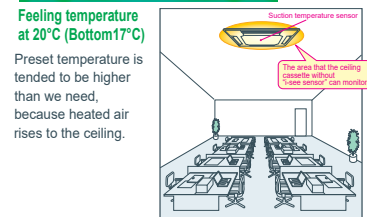

With i-see sensor* Auto fan speed: preset temperature at 20°C

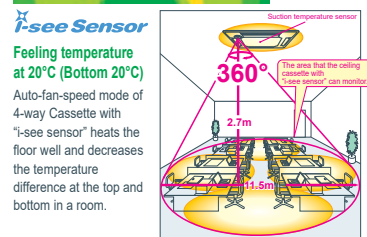

► Specifications

		PLFY-P32VBM-E	PLFY-P40VBM-E	PLFY-P50VBM-E	
Power source		1-phase 220-240V 50Hz / 1-phase 220V 60Hz			
Cooling capacity	*1 kW	3.6	4.5	5.6	
	*1 BTU/h	12,300	15,400	19,100	
Heating capacity	*1 kW	4.0	5.0	6.3	
	*1 BTU/h	13,600	17,100	21,500	
Power consumption	Cooling kW	0.03	0.04	0.04	
	Heating kW	0.02	0.03	0.03	
Current	Cooling A	0.27	0.29	0.29	
	Heating A	0.20	0.22	0.22	
External finish		Galvanized steel sheet			
(Munsell No.)		MUNSELL (6.4Y 8.9/0.4)			
Dimension H x W x D	Unit mm(in.)	258 x 840 x 840 (10-3/16 x 33-1/8 x 33-1/8)			
	Panel mm(in.)	35 x 950 x 950 (1-3/8 x 37-7/16 x 37-7/16)			
Net weight	Unit kg(lbs.)	22 (49)			
	Panel kg(lbs.)	6 (13)			
Heat exchanger		Cross fin (Aluminum fin and copper tube)			
Fan	Type x Quantity		Turbo fan x 1		
	Airflow rate *2 (Lo-Mid2-Mid1-Hi)	m³/min	11-12-13-14	12-13-14-16	
		L/s	183-200-217-233	200-217-233-267	
		cfm	388-424-459-494	424-459-494-565	
	External static pressure	Pa	0		
Motor	Type	DC motor			
	Output	kW 0.050			
Air filter		PP Honeycomb			
Refrigerant pipe diameter	Gas (Flare) mm(in.)	ø12.7 (ø1/2)		ø12.7 (ø1/2) / ø15.88 (ø5/8) (Compatible)	
	Liquid (Flare) mm(in.)	ø6.35 (ø1/4)		ø6.35 (ø1/4) / ø9.52 (ø3/8) (Compatible)	
Field drain pipe diameter	mm(in.)	O.D. 32 (1-1/4)			
Sound pressure level *2 *3 (Lo-Mid2-Mid1-Hi)	dB(A)	27-28-29-31	27-28-30-31		

		PLFY-P63VBM-E	PLFY-P80VBM-E	PLFY-P100VBM-E	PLFY-P125VBM-E	
Power source		1-phase 220-240V 50Hz / 1-phase 220V 60Hz				
Cooling capacity	*1 kW	7.1	9.0	11.2	14.0	
	*1 BTU/h	24,200	30,700	38,200	47,800	
Heating capacity	*1 kW	8.0	10.0	12.5	16.0	
	*1 BTU/h	27,300	34,100	42,700	54,600	
Power consumption	Cooling kW	0.05	0.07	0.15	0.16	
	Heating kW	0.04	0.06	0.14	0.15	
Current	Cooling A	0.36	0.51	1.00	1.07	
	Heating A	0.29	0.43	0.94	1.00	
External finish		Galvanized steel sheet				
(Munsell No.)		MUNSELL (6.4Y 8.9/0.4)				
Dimension H x W x D	Unit mm(in.)	258 x 840 x 840 (10-3/16 x 33-1/8 x 33-1/8)				
	Panel mm(in.)	35 x 950 x 950 (1-3/8 x 37-7/16 x 37-7/16)				
Net weight	Unit kg(lbs.)	23 (51)		27 (60)		
	Panel kg(lbs.)	6 (13)				
Heat exchanger		Cross fin (Aluminum fin and copper tube)				
Fan	Type x Quantity		Turbo fan x 1			
	Airflow rate *2 (Lo-Mid2-Mid1-Hi)	m³/min	14-15-16-18	16-18-20-22	21-24-27-29	22-25-28-30
		L/s	233-250-267-300	267-300-333-367	350-400-450-483	367-417-467-500
		cfm	494-530-565-636	565-636-706-777	742-848-953-1024	777-883-989-1059
	External static pressure	Pa	0			
Motor	Type	DC motor				
	Output	kW 0.050		0.120		
Air filter		PP Honeycomb				
Refrigerant pipe diameter	Gas (Flare) mm(in.)	ø15.88 (ø5/8)		ø15.88 (ø5/8) / ø19.05 (ø3/4) (Compatible)		
	Liquid (Flare) mm(in.)	ø9.52 (ø3/8)				
Field drain pipe diameter	mm(in.)	O.D. 32 (1-1/4)				
Sound pressure level *2 *3 (Lo-Mid2-Mid1-Hi)	dB(A)	28-29-30-32	30-32-35-37	34-37-39-41	35-38-41-43	

Notes:

- *1 Cooling/Heating capacity indicates the maximum value at operation under the following condition.
Cooling : Indoor 27°C(81°F)DB/19°C(66°F)WB, Outdoor 35°C(95°F)DB
Heating : Indoor 20°C(68°F)DB, Outdoor 7°C(45°F)DB/6°C(43°F)WB
- *2 Airflow rate/Sound pressure level are in (Lo-Mid-Hi) or (Lo-Mid1-Mid2-Hi).
- *3 It is measured in anechoic room at power source 230V.

INDOOR UNIT Ceiling cassette type 4-way airflow

NEW

PLFY-P VFM-E 3D i-see Sensor



Mitsubishi Electric's new VFM 4-way cassette series features a sleek, compact design and the new 3D i-See Sensor.



New Capacity Line-up

New capacities have been introduced to expand the line-up. The diverse range available ensures the best solution for the customer and application.

	1.5kW	2.0kW	2.5kW	3.2kW	4.0kW	5.0kW
NEW PLYF-P VFM	✓	✓	✓	✓	✓	✓

Airflow Control

Horizontal airflow

Horizontal airflow mode can be used to avoid drafts and discomfort to occupants. By directing the airflow horizontally, the unit creates a draft-free environment even at higher fan speeds.

Quietness

The sound level has been reduced by 2-4dB thanks to the introduction of a 3D turbo fan, for quieter and more comfortable air conditioning.

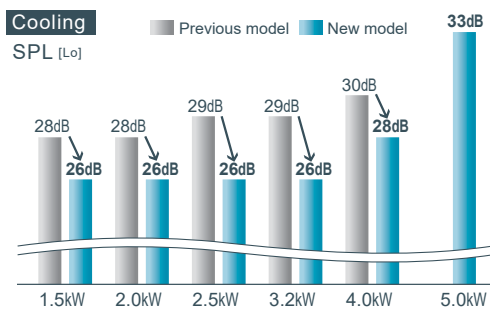

IT terminal

IT terminal is available. For details, contact your local distributor.

Indoor Unit

Industry Leading Slim-line Design

With a height of only 245mm, new VFM cassette has been designed to fit within confined ceiling spaces.

The height above ceiling of 245mm is top class in the industry.*

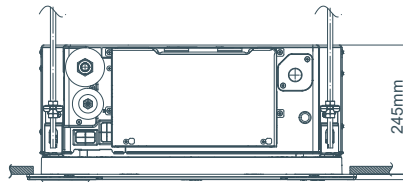

* As of Aug 2015. Among compact 4-way cassettes for system ceiling.

3D i-see Sensor

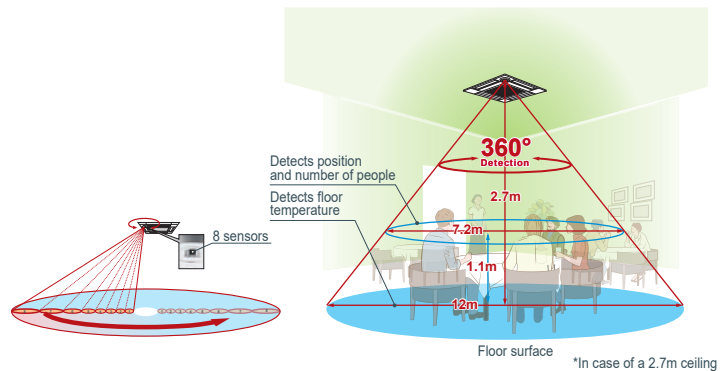

Occupancy Sensor

This intelligent 8-element sensor simultaneously scans the room and divides it into 752 three-dimensional zones, measuring the temperature in each to detect the exact position of occupants based on their heat signatures.

The 3D i-See Sensor is also an intuitive occupancy sensor that, after a set period of absence, will switch to energy saving operation, raising or lowering the set temperature by 2°C for greater energy savings. When occupants return, the sensor detects the change and reverts to the pre-set mode.

► Specifications

			PLFY-P15VFM-E	PLFY-P20VFM-E	PLFY-P25VFM-E	PLFY-P32VFM-E	PLFY-P40VFM-E	PLFY-P50VFM-E
Power source			1-phase 220-240V 50Hz / 220V 60Hz					
Cooling capacity	*1	kW	1.7	2.2	2.8	3.6	4.5	5.6
	*1	BTU/h	5,800	7,500	9,600	12,300	15,400	19,100
Heating capacity	*1	kW	1.9	2.5	3.2	4.0	5.0	6.3
	*1	BTU/h	6,500	8,500	10,900	13,600	17,100	21,500
Power consumption	Cooling	kW	0.02	0.02	0.02	0.02	0.03	0.04
	Heating	kW	0.02	0.02	0.02	0.02	0.03	0.04
Current	Cooling	A	0.19	0.21	0.22	0.23	0.28	0.40
	Heating	A	0.14	0.16	0.17	0.18	0.23	0.35
External finish (Munsell No.)	Unit	Galvanized steel sheet						
	Panel	MUNSELL (6.4Y 8.9/0.4)						
Dimension H x W x D	Unit	mm(in.)	208 x 570 x 570 (8-1/4 x 22-1/2 x 22-1/2)					
	Panel	mm(in.)	10 x 625 x 625 (3/8 x 24-5/8 x 24-5/8)					
Net weight	Unit	kg(lbs.)	14 (31)			15 (33)		
	Panel	kg(lbs.)	3 (7)					
Heat exchanger			Cross fin (Aluminum fin and copper tube)					
Fan	Type x Quantity		Turbo fan x 1					
	Airflow rate *2 (Lo-Mid-Hi)	m ³ /min	6.5-7.5-8.0	6.5-7.5-8.5	6.5-8.0-9.0	7.0-8.0-9.5	7.5-9.0-11.0	9.0-11.0-13.0
		L/s	108-125-133	108-125-142	108-133-150	117-133-158	125-150-183	150-183-217
	(Lo-Mid1-Mid2-Hi)	cfm	230-265-282	230-265-300	230-282-318	247-282-335	265-318-388	318-388-459
External static pressure	Pa	0						
Motor	Type		DC motor					
	Output		0.05					
Air filter			PP Honeycomb fabric (long life type)					
Refrigerant pipe diameter	Gas (Flare)	mm(in.)	ø12.7 (ø1/2)					
	Liquid (Flare)	mm(in.)	ø6.35 (ø1/4)					
Field drain pipe diameter			O.D. 32 (1-1/4) (PVC pipe VP-25 connectable)					
Sound pressure level *2 *3 (Lo-Mid-Hi) (Lo-Mid1-Mid2-Hi)		dB(A)	26-28-30	26-29-31	26-30-33	26-30-34	28-33-39	33-39-43

Notes:

*1 Cooling/Heating capacity indicates the maximum value at operation under the following condition.
Cooling : Indoor 27°C(81°F)DB/19°C(66°F)WB, Outdoor 35°C(95°F)DB
Heating : Indoor 20°C(68°F)DB, Outdoor 7°C(45°F)DB/6°C(43°F)WB

*2 Airflow rate/Sound pressure level are in (Lo-Mid-Hi) or (Lo-Mid1-Mid2-Hi).

*3 It is measured in anechoic room at power source 230V.

INDOOR UNIT

Ceiling cassette type

2-way airflow

PLFY-P VLMD-E



Slim body of 290mm(11-7/16in.) height



Equipped with drain pump mechanism as standard

The drain can be positioned anywhere up to 583mm(22-15/16in.) from the ceiling's surface, providing greater freedom with long cross-piping and allowing more versatility with piping layouts.

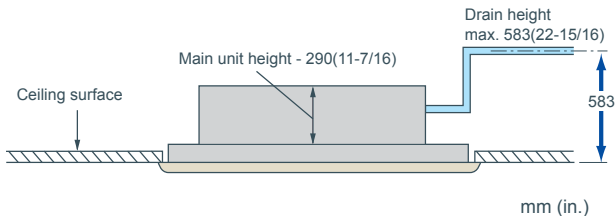

Slim body - only 290mm(11-7/16in.) height

The slimline body is highly suitable for installation in narrow ceiling spaces and for replacing obsolete air-conditioning equipment in older buildings. The main unit is only 290mm(11-7/16in.) height.

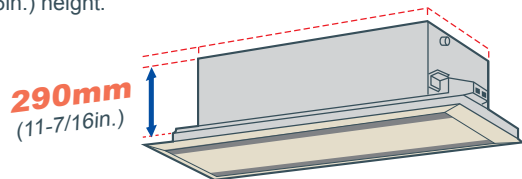

Terminal block on outside of main unit makes wiring easier

Compact unit and low noise level attained!

Sound pressure level table (Standard static pressure) at 0Pa

Sound pressure Level	Capacity		dB(A)										
	Fan Speed	High	P20	P25	P32	P40	P50	P63	P80	P100	P125		
		Mid	Low										
	High	33			36	37	39	39	42	46			
	Mid	30			33	34	37	36	39	42/44			
	Low	27			29	31	32	33	36	40			

<220V,240V>

Sound pressure Level	Capacity		dB(A)										
	Fan Speed	High	P20	P25	P32	P40	P50	P63	P80	P100	P125		
		Mid	Low										
	High	34			37	38	40	40	43	46			
	Mid	31			34	35	38	37	41	42/44			
	Low	28			30	32	33	34	37	40			

<230V>

Fresh air directly taken in

Fresh air can be taken in to the main unit directly (optional accessories needed.)

Long life filter equipped as standard

The antibacterial long life filter does not require maintenance for approximately a year.

Easy installation

Lighter panel and placing the electric board near the panel make installation and maintenance easier. Also, the heat exchanger is washable by displacing the center panel, filter, and fan.

► Specifications

		PLFY-P20VLMD-E	PLFY-P25VLMD-E	PLFY-P32VLMD-E	PLFY-P40VLMD-E	
Power source		1-phase 220-240V 50Hz / 1-phase 220-230V 60Hz				
Cooling capacity	*1 kW	2.2	2.8	3.6	4.5	
	*1 BTU/h	7,500	9,600	12,300	15,400	
Heating capacity	*1 kW	2.5	3.2	4.0	5.0	
	*1 BTU/h	8,500	10,900	13,600	17,100	
Power consumption	Cooling kW	0.072 / 0.075	0.072 / 0.075	0.072 / 0.075	0.081 / 0.085	
	Heating kW	0.065 / 0.069	0.065 / 0.069	0.065 / 0.069	0.074 / 0.079	
Current	Cooling A	0.36 / 0.37	0.36 / 0.37	0.36 / 0.37	0.40 / 0.42	
	Heating A	0.30 / 0.32	0.30 / 0.32	0.30 / 0.32	0.34 / 0.37	
External finish (Munsell No.)	Unit	Galvanized steel plate				
	Panel	Pure white (6.4Y 8.9/0.4)				
Dimension H x W x D	Unit mm (in.)	290 x 776 x 634 (11-7/16 x 30-9/16 x 25)				
	Panel mm (in.)	20 x 1080 x 710 (13/16 x 42-9/16 x 28)				
Net weight	Unit kg(lbs.)	23 (51)		24 (53)		
	Panel kg(lbs.)	6.5 (15)				
Heat exchanger		Cross fin				
Fan	Type x Quantity	Turbo fan x 1				
	Airflow rate *2 (Lo-Mid-Hi)	m ³ /min	6.5-8.0-9.5		7.0-8.5-10.5	
		L/s	108-133-158		117-142-175	
	External static pressure	cfm	230-283-335		247-300-371	
	Pa	0				
Motor	Type	1-phase induction motor				
	Output kW	0.015 (at 240V)				
Air filter		PP honeycomb fabric (long life type)				
Refrigerant pipe diameter	Gas(Flare) mm(in.)	ø12.7 (ø1/2)				
	Liquid(Flare) mm(in.)	ø6.35 (ø1/4)				
Field drain pipe diameter		mm(in.) O.D.32 (1-1/4)				
Sound pressure level (Lo-Mid-Hi) *2 *3	220V,240V dB(A)	27-30-33			29-33-36	
	230V dB(A)	28-31-34			30-34-37	

		PLFY-P50VLMD-E	PLFY-P63VLMD-E	PLFY-P80VLMD-E	PLFY-P100VLMD-E	PLFY-P125VLMD-E	
Power source		1-phase 220-240V 50Hz / 1-phase 220-230V 60Hz					
Cooling capacity	*1 kW	5.6	7.1	9.0	11.2	14.0	
	*1 BTU/h	19,100	24,200	30,700	38,200	47,800	
Heating capacity	*1 kW	6.3	8.0	10.0	12.5	16.0	
	*1 BTU/h	21,500	27,300	34,100	42,700	54,600	
Power consumption	Cooling kW	0.082 / 0.086	0.101 / 0.105	0.147 / 0.156	0.157 / 0.186	0.28 / 0.28	
	Heating kW	0.075 / 0.080	0.094 / 0.099	0.140 / 0.150	0.150 / 0.180	0.27 / 0.27	
Current	Cooling A	0.41 / 0.43	0.49 / 0.51	0.72 / 0.74	0.75 / 0.88	1.35 / 1.35	
	Heating A	0.35 / 0.38	0.43 / 0.46	0.66 / 0.69	0.69 / 0.83	1.33 / 1.33	
External finish (Munsell No.)	Unit	Galvanized steel plate					
	Panel	Pure white (6.4Y 8.9 / 0.4)					
Dimension H x W x D	Unit mm (in.)	290 x 946 x 634 (11-7/16 x 37-1/4 x 25)	290 x 1446 x 634 (11-7/16 x 56-15/16 x 25)		290 x 1708 x 606 (11-7/16 x 67-1/4 x 23-7/8)		
	Panel mm (in.)	20 x 1250 x 710 (13/16 x 49-1/4 x 28)	20 x 1750 x 710 (13/16 x 68-15/16 x 28)		20 x 2010 x 710 (13/16 x 79-3/16 x 28)		
Net weight	Unit kg(lbs.)	27 (60)	28 (62)	44 (98)	47 (104)	56 (124)	
	Panel kg(lbs.)	7.5 (17)		12.5 (28)		13.0 (29)	
Heat exchanger		Turbo fan x 1		Turbo fan x 2		Sirocco fan x 4	
Fan	Type x Quantity	Turbo fan x 1		Turbo fan x 2		Sirocco fan x 4	
	Airflow rate *2 (P50-P100:Lo-Mid-Hi)	m ³ /min	9.0-11.0-12.5	11.0-13.0-15.5	15.5-18.5-22.0	17.5-21.0-25.0	24.0-27.0-30.0-33.0
		L/s	150-183-208	167-217-258	258-308-367	292-350-417	400-450-500-550
	(P125:Lo-Mid2-Mid1-Hi)	cfm	318-388-441	353-459-547	547-653-777	618-742-883	848-953-1,059-1,165
External static pressure	Pa	0					
Motor	Type	1-phase induction motor					
	Output kW	0.020 (at 240V)		0.020 (at 240V)	0.030 (at 240V)	0.078 x 2 (at 240V)	
Air filter		PP honeycomb fabric (long life type)				Synthetic fiber unwoven cloth filter (long life)	
Refrigerant pipe diameter	Gas (Flare) mm(in.)	ø12.7 (ø1/2)	ø15.88 (ø5/8)				
	Liquid (Flare) mm(in.)	ø6.35 (ø1/4)	ø9.52 (ø3/8)				
Field drain pipe diameter		mm(in.) O.D.32 (1-1/4)					
Sound pressure level (Lo-Mid-Hi) *2 *3	220V,240V dB(A)	31-34-37	32-37-39	33-36-39	36-39-42	40-42-44-46	
	230V dB(A)	32-35-38	33-38-40	34-37-40	37-41-43	(Lo-Mid2-Mid1-Hi)	

Notes:

*1 Cooling/Heating capacity indicates the maximum value at operation under the following condition.
Cooling : Indoor 27°C(81°F)DB/19°C(66°F)WB, Outdoor 35°C(95°F)DB
Heating : Indoor 20°C(68°F)DB, Outdoor 7°C(45°F)DB/6°C(43°F)WB

*2 Airflow rate/Sound pressure level are in (low-middle-high) or (low-middle2-middle1-high).

*3 It is measured in anechoic room.

INDOOR UNIT

Ceiling cassette type

1-way airflow

PMFY-P VBM-E

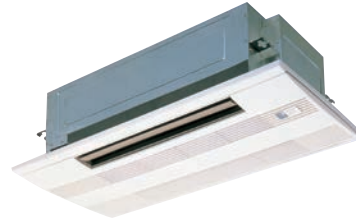

Compact and lightweight body perfect for limited ceiling space applications.



Compact size for smooth installation and maintenance

Unit body size has been standardised for all models at 812mm for easier installation. Body weight is only 14kg for the main unit and 3kg for the panel, making this unit one of the lightest in the industry.

Quiet operation

Newly developed airflow control technology reduces noise level to only 27dB (P20VBM) for industry-leading quiet performance.

Sound pressure level table

Sound pressure level	Capacity				
	Fan Speed	P20	P25	P32	P40
	High	35	37	39	
	Mid 1	33	36	37	
	Mid 2	30	34	35	
	Low	27	32	33	

<220V,240V>

Drain pump

The drain can be positioned anywhere up to 500mm from the ceiling's surface.

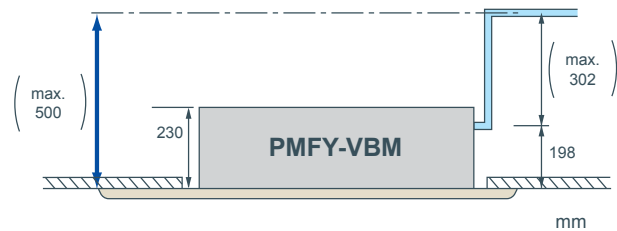

► Specifications

			PMFY-P20VBM-E	PMFY-P25VBM-E	PMFY-P32VBM-E	PMFY-P40VBM-E
Power source			1-phase 220-240V 50Hz / 1-phase 220V 60Hz			
Cooling capacity	*1	kW	2.2	2.8	3.6	4.5
	*1	BTU/h	7,500	9,600	12,300	15,400
Heating capacity	*1	kW	2.5	3.2	4.0	5.0
	*1	BTU/h	8,500	10,900	13,600	17,100
Power consumption	Cooling	kW	0.044			0.054
	Heating	kW	0.044			0.054
Current	Cooling	A	0.21			0.26
	Heating	A	0.21			0.26
External finish (Munsell No.)			White (0.98Y 8.99/0.63)			
Dimension	Unit	mm(in.)	230 x 812 x 395 (9-1/16 x 32 x 15-9/16)			
	Panel	mm(in.)	30 x 1000 x 470 (1-3/16 x 39-3/8 x 18-9/16)			
Net weight	Unit	kg(lbs.)	14 (31)			
	Panel	kg(lbs.)	3 (7)			
Heat exchanger			Cross fin (Aluminum plate fin and copper tube)			
Fan	Type		Line flow fan x 1			
	Airflow rate *2 (Lo-Mid2-Mid1-Hi)	m ³ /min	6.5-7.2-8.0-8.7	7.3-8.0-8.6-9.3	7.7-8.7-9.7-10.7	
		L/s	108-120-133-145	122-133-143-155	128-145-162-178	
	External static pressure	Pa	230-254-283-307	258-283-304-328	272-307-343-378	
Motor	Type		1-phase induction motor			
	Output	kW	0.028			
Air filter			PP Honeycomb fabric			
Refrigerant pipe diameter	Gas(Flare)	mm(in.)	ø12.7 (ø1/2)			
	Liquid(Flare)	mm(in.)	ø6.35 (ø1/4)			
Field drain pipe diameter			mm(in.) O.D. 26 (1)			
Sound pressure level (Lo-Mid2-Mid1-Hi) *2 *3			27-30-33-35	32-34-36-37	33-35-37-39	

Notes:

- *1 Cooling/Heating capacity indicates the maximum value at operation under the following condition.
Cooling : Indoor 27°C(81°F)DB/19°C(66°F)WB, Outdoor 35°C(95°F)DB
Heating : Indoor 20°C(68°F)DB, Outdoor 7°C(45°F)DB/6°C(43°F)WB
- *2 Airflow rate/Sound pressure level are in (low-middle2-middle1-high).
- *3 It is measured in anechoic room.

INDOOR UNIT

Low Static Ducted Units

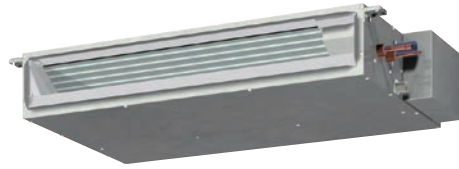

PEFY-P VMS1(L)-E

Static Pressure 5~50Pa	Height 200mm <small>7-28/32in.</small>	Low Noise	Width 790mm <small>31-1/8in.</small>	Width 990mm <small>39in.</small>	Width 1,190mm <small>46-7/8in.</small>
----------------------------------	---	-----------	---	---	---

The ultra thin unit of 200mm offers increased flexibility, and is particularly suitable for places where low noise operation is desired.



Changeable static pressure

The unit is made suitable for a variety of applications with its four static pressure settings of 5, 15, 35, 50Pa.

Changeable airflow rate

Low, middle, and high fan speed settings deliver precise comfort.

Optional drain pump

Drain pump is an optional part for the VMS1L, and a standard for VMS1.

*For places where low noise operation is especially required (i.e. Hotels), VMS1L (without drain pump) is recommended.

PP Honeycomb fabric

Washable PP Honeycomb fabric filter as standard.

**Ultra low height unit with 200mm (7-28/32in.) high
Ultra-narrow width of 790mm (P15-P32 models)
[990mm for P40,50 models / 1190mm for P63 models]**

Can be installed easily in tight spaces, such as ceiling cavities or drop-ceilings.

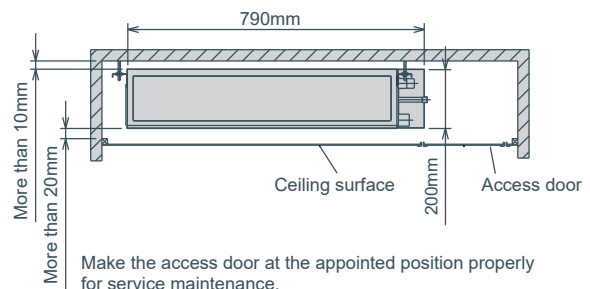

Reduced noise thanks to the use of newly designed centrifugal fan and coil

Sound pressure level table (Standard static pressure) at 15Pa

		dB(A)							
Sound pressure Level	Capacity	P15	P20	P25	P32	P40	P50	P63	
	Fan Speed	High	28	29	30	32	33	35	36
Mid		24	25	26	27	30	32	33	
Low		22	23	24	24	28	30	30	

► Specifications

		PEFY-P15VMS1(L)-E	PEFY-P20VMS1(L)-E	PEFY-P25VMS1(L)-E	PEFY-P32VMS1(L)-E	PEFY-P40VMS1(L)-E	PEFY-P50VMS1(L)-E	PEFY-P63VMS1(L)-E	
Power source		1-phase 220-240V 50Hz / 1-phase 220-240V 60Hz							
Cooling capacity	*1 kW	1.7	2.2	2.8	3.6	4.5	5.6	7.1	
	*1 BTU/h	5,800	7,500	9,600	12,300	15,400	19,100	24,200	
Heating capacity	*1 kW	1.9	2.5	3.2	4.0	5.0	6.3	8.0	
	*1 BTU/h	6,500	8,500	10,900	13,600	17,100	21,500	27,300	
Power consumption	*3 Cooling kW	0.05 [0.03]	0.05 [0.03]	0.06 [0.04]	0.07 [0.05]	0.07 [0.05]	0.09 [0.07]	0.09 [0.07]	
	*3 Heating kW	0.03 [0.03]	0.03 [0.03]	0.04 [0.04]	0.05 [0.05]	0.05 [0.05]	0.07 [0.07]	0.07 [0.07]	
Current	*3 Cooling A	0.42 [0.31]	0.47 [0.36]	0.50 [0.39]	0.50 [0.39]	0.56 [0.45]	0.67 [0.56]	0.72 [0.61]	
	*3 Heating A	0.31 [0.31]	0.36 [0.36]	0.39 [0.39]	0.39 [0.39]	0.45 [0.45]	0.56 [0.56]	0.61 [0.61]	
External finish		Galvanized							
Dimension		200 x 790 x 700				200 x 990 x 700		200 x 1,190 x 700	
H x W x D		In. 7-7/8 x 31-1/8 x 27-9/16				7-7/8 x 39 x 27-9/16		7-7/8 x 46-7/8 x 27-9/16	
Net weight		*3 kg(lbs.) 19(42) [18(40)]			20(45) [19(42)]		24(53) [23(51)]	28(62) [27(60)]	
Heat exchanger		Cross fin (Aluminium fin and copper tube)							
Fan	Type x Quantity	Sirocco fan x 2			Sirocco fan x 3		Sirocco fan x 4		
	Airflow rate (Lo-Mid-Hi)	m ³ /min	5-6-7	5.5-6.5-8	5.5-7-9	6-8-10	8-9.5-11	9.5-11-13	12-14-16.5
		L/s	83-100-117	91-108-133	91-117-150	100-133-167	133-158-183	158-183-217	200-233-275
	cfm	176-212-247	194-229-282	194-247-317	212-282-353	282-335-388	335-388-459	424-494-583	
External static press	Pa	5-15-35-50							
Motor	type	DC motor							
	output	kW 0.096							
Air filter		PP Honeycomb fabric (washable)							
Refrigerant pipe diameter	Gas	mm(in.) ø12.7 (ø1/2) Brazed					ø15.88 (ø5/8) Brazed		
	Liquid	mm(in.) ø6.35 (ø1/4) Brazed					ø9.52 (ø3/8) Brazed		
Field drain pipe diameter		mm(in.) O.D. 32 (1-1/4)							
Sound pressure level (Lo-Mid-Hi) (measured in anechoic room)		dB<A>	22-24-28	23-25-29	24-26-30	24-27-32	28-30-33	30-32-35	30-33-36

Notes:

*1 Cooling/Heating capacity indicates the maximum value at operation under the following condition.
 Cooling : Indoor : 27°C D.B./19°C W.B. (81°F D.B. / 66°F W.B.) Outdoor : 35°C D.B. (95°F D.B.)
 Heating : Indoor : 20°C D.B. (68°F D.B.) Outdoor : 7°C D.B. / 6°C W.B. (45°F D.B. / 43°F W.B.)
 Pipe length : 7.5m (24-9/16ft) Height difference : 0m (0ft)

*2 The external static pressure is set to 15 Pa at factory shipment.

*3 [] is in case of PEFY-P15-63VMS1L-E

INDOOR UNIT

Mid Static Ducted Units

PEFY-P VMA(L)-E

Middle Static Pressure
35~150Pa

Slim Body
Height 250mm

Precise control of indoor temperatures while operating with optimum energy usage, offering high-energy saving efficiency.



Compact Indoor Units

For all models, unit heights are unified to 250mm. Compared to the previous model, the height size is reduced, allowing installation in tight spaces, such as ceiling cavities or drop-ceilings.

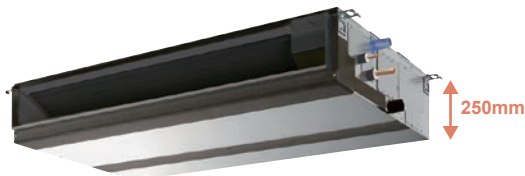

Reduction in height size

PEFY-P VMA(L)	20	25	32	40	50	63	71	80	100	125	140
Height mm	250										
Width mm	700		900		1,100		1,400		1,600		
Depth mm	732										

External static pressure

Five-stage external static pressure settings provide flexibility for duct extension, branching and air outlet configuration and are adjustable to meet different application conditions.

Setting ranges to a maximum of 150Pa.

External static pressure setting

Series	20	25	32	40	50	63	71	80	100	125	140
PEFY-P VMA(L)	35/50/70/100/150Pa										

Air Inlet

(1) Rear inlet

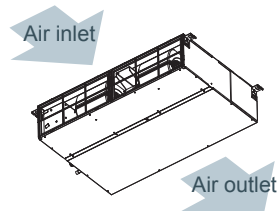

(2) Bottom inlet

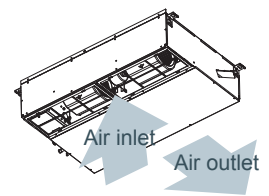

Drain Pump Option

The line-up consists of two types, models with or without a built-in drain pump allowing more freedom in piping layout design.



PEFY-P VMA-E Drain pump built-in



PEFY-P VMA(L)-E No Drain pump

* Units with a "L" at the end of the model name are not equipped with a drain pump.

Analogue input

Analogue input allows units to control the fan speed setting in conjunction with damper conditions.

IT terminal

IT terminals are available. For details, contact your local distributor.

► Specifications

		PEFY-P20VMA(L)-E	PEFY-P25VMA(L)-E	PEFY-P32VMA(L)-E	PEFY-P40VMA(L)-E	PEFY-P50VMA(L)-E	
Power source		1-phase 220-230-240V 50 / 60Hz					
Cooling capacity (Nominal) *1	kW	2.2	2.8	3.6	4.5	5.6	
	BTU/h	7,500	9,600	12,300	15,400	19,100	
Heating capacity (Nominal) *2	kW	2.5	3.2	4.0	5.0	6.3	
	BTU/h	8,500	10,900	13,600	17,100	21,500	
Power consumption	Cooling *3	kW	0.06 [0.04]	0.06 [0.04]	0.07 [0.05]	0.09 [0.07]	0.11 [0.09]
	Heating *3	kW	0.04	0.04	0.05	0.07	0.09
Current	Cooling *3	A	0.53 [0.42]	0.53 [0.42]	0.55 [0.44]	0.64 [0.53]	0.74 [0.63]
	Heating *3	A	0.42	0.42	0.44	0.53	0.63
External finish		Galvanized steel plate					
Dimension H x W x D	mm	250 x 700 x 732	250 x 700 x 732	250 x 700 x 732	250 x 900 x 732	250 x 900 x 732	
	in.	9-7/8 x 27-9/16 x 28-7/8	9-7/8 x 27-9/16 x 28-7/8	9-7/8 x 27-9/16 x 28-7/8	9-7/8 x 35-7/16 x 28-7/8	9-7/8 x 35-7/16 x 28-7/8	
Net weight	kg(lbs)	23 (51) [22 (49)]	23 (51) [22 (49)]	23 (51) [22 (49)]	26 (58) [25 (56)]	26 (58) [25 (56)]	
Heat exchanger		Cross fin (Aluminum fin and copper tube)					
Fan	Type x Quantity	Sirocco fan x 1					
	Airflow rate (Low-Mid-High)	m ³ /min	6.0 - 7.5 - 8.5	6.0 - 7.5 - 8.5	7.5 - 9.0 - 10.5	10.0 - 12.0 - 14.0	12.0 - 14.5 - 17.0
		L/s	100 - 125 - 142	100 - 125 - 142	125 - 150 - 175	167 - 200 - 233	200 - 242 - 283
		cfm	212 - 265 - 300	212 - 265 - 300	265 - 318 - 371	353 - 424 - 494	424 - 512 - 600
External static pressure *4	Pa	<35> - 50 - <70> - <100> - <150>	<35> - 50 - <70> - <100> - <150>	<35> - 50 - <70> - <100> - <150>	<35> - 50 - <70> - <100> - <150>	<35> - 50 - <70> - <100> - <150>	
Motor	Type	DC motor					
	Output	kW	0.085	0.085	0.085	0.085	0.085
Air filter		PP honeycomb fabric.					
Refrigerant pipe diameter	Liquid (R410A) (R22,R407C)	mm(in.)	6.35 (1/4) Brazed	6.35 (1/4) Brazed	6.35 (1/4) Brazed	6.35 (1/4) Brazed	6.35 (1/4) Brazed
	Gas (R410A) (R22,R407C)	mm(in.)	12.7 (1/2) Brazed	12.7 (1/2) Brazed	12.7 (1/2) Brazed	12.7 (1/2) Brazed	12.7 (1/2) Brazed
Field drain pipe diameter	mm(in.)	O.D.32 (1-1/4)	O.D.32 (1-1/4)	O.D.32 (1-1/4)	O.D.32 (1-1/4)	O.D.32 (1-1/4)	
Sound pressure level (measured in anechoic room)							
(Low-Mid-High) *3 *5	dB(A)	26-28-29	26-28-29	28-30-34	28-30-34	28-32-35	
	*3 *6	dB(A)	23-25-26	23-25-26	23-26-29	23-27-30	

		PEFY-P63VMA(L)-E	PEFY-P71VMA(L)-E	PEFY-P80VMA(L)-E	PEFY-P100VMA(L)-E	PEFY-P125VMA(L)-E	PEFY-P140VMA(L)-E	
Power source		1-phase 220-230-240V 50 / 60Hz						
Cooling capacity (Nominal) *1	kW	7.1	8.0	9.0	11.2	14.0	16.0	
	BTU/h	24,200	27,300	30,700	38,200	47,800	54,600	
Heating capacity (Nominal) *2	kW	8.0	9.0	10.0	12.5	16.0	18.0	
	BTU/h	27,300	30,700	34,100	42,700	54,600	61,400	
Power consumption	Cooling *3	kW	0.12 [0.10]	0.14 [0.12]	0.14 [0.12]	0.24 [0.22]	0.34 [0.32]	0.36 [0.34]
	Heating *3	kW	0.10	0.12	0.12	0.22	0.32	0.34
Current	Cooling *3	A	1.01 [0.90]	1.15 [1.04]	1.15 [1.04]	1.47 [1.36]	2.05 [1.94]	2.21 [2.10]
	Heating *3	A	0.90	1.04	1.04	1.36	1.94	2.10
External finish		Galvanized steel plate						
Dimension H x W x D	mm	250 x 1,100 x 732	250 x 1,100 x 732	250 x 1,100 x 732	250 x 1,400 x 732	250 x 1,400 x 732	250 x 1,600 x 732	
	in.	9-7/8 x 43-5/16 x 28-7/8	9-7/8 x 43-5/16 x 28-7/8	9-7/8 x 43-5/16 x 28-7/8	9-7/8 x 55-1/8 x 28-7/8	9-7/8 x 55-1/8 x 28-7/8	9-7/8 x 63 x 28-7/8	
Net weight	kg(lbs)	32 (71) [31(69)]	32 (71) [31 (69)]	32 (71) [31 (69)]	42 (93) [41 (91)]	42 (93) [41 (91)]	46 (102) [45 (10)]	
Heat exchanger		Cross fin (Aluminum fin and copper tube)						
Fan	Type x Quantity	Sirocco fan x 2						
	Airflow rate (Low-Mid-High)	m ³ /min	13.5 - 16.0 - 19.0	14.5 - 18.0 - 21.0	14.5 - 18.0 - 21.0	23.0 - 28.0 - 33.0	28.0 - 34.0 - 40.0	29.5 - 35.5 - 42.0
		L/s	225 - 267 - 317	242 - 300 - 350	242 - 300 - 350	383 - 467 - 550	467 - 567 - 667	492 - 592 - 700
		cfm	477 - 565 - 671	512 - 636 - 742	512 - 636 - 742	812 - 989 - 1,165	989 - 1,201 - 1,412	1,042 - 1,254 - 1,483
External static pressure *4	Pa	<35> - 50 - <70> - <100> - <150>	<35> - 50 - <70> - <100> - <150>	<35> - 50 - <70> - <100> - <150>	<35> - 50 - <70> - <100> - <150>	<35> - 50 - <70> - <100> - <150>	<35> - 50 - <70> - <100> - <150>	
Motor	Type	DC motor						
	Output	kW	0.121	0.121	0.121	0.244	0.244	0.244
Air filter		PP honeycomb fabric.						
Refrigerant pipe diameter	Liquid (R410A) (R22,R407C)	mm(in.)	9.52 (3/8) Brazed	9.52 (3/8) Brazed	9.52 (3/8) Brazed	9.52 (3/8) Brazed	9.52 (3/8) Brazed	9.52 (3/8) Brazed
	Gas (R410A) (R22,R407C)	mm(in.)	15.88 (5/8) Brazed	15.88 (5/8) Brazed	15.88 (5/8) Brazed	15.88 (5/8) Brazed	15.88 (5/8) Brazed	15.88 (5/8) Brazed
Field drain pipe diameter	mm(in.)	O.D.32 (1-1/4)	O.D.32 (1-1/4)	O.D.32 (1-1/4)	O.D.32 (1-1/4)	O.D.32 (1-1/4)	O.D.32 (1-1/4)	
Sound pressure level (measured in anechoic room)								
(Low-Mid-High) *3 *5	dB(A)	29-32-36	30-34-38	30-34-38	32-37-41	35-40-44	36-41-45	
	*3 *6	dB(A)	25-29-33	26-29-34	26-29-34	28-33-37	32-36-40	33-37-42

Notes:

- * [] is in case of PEFY-P VMALE
- *1 Nominal cooling conditions
Indoor: 27°CDB/19°CWB(81°FDB/66°FWB), Outdoor: 35°CDB(95°FDB)
Pipe length: 7.5m(24-9/16ft.), Level difference: 0m(0ft.)
- *2 Nominal heating conditions
Indoor: 20°CDB(68°FDB), Outdoor: 7°CDB/6°CWB(45°FDB/43°FWB)
Pipe length: 7.5m(24-9/16ft.), Level difference: 0m(0ft.)
- *3 The values are measured at the rated external static pressure.
- *4 The rated external static pressure is shown with < >. The factory setting is the rated value.

- *5 Measured in anechoic room with a 1m air inlet duct and 2m air outlet duct attached to the unit and 1.5m below the unit.

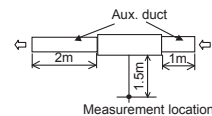

- *6 Measured in anechoic room with a 2m air inlet duct and 2m air outlet duct attached to the unit and 1.5m below the unit.

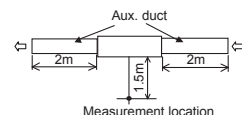

INDOOR UNIT

High Static Ducted Units

PEFY-P VMH(S)-E

High Static Pressure



Increased design flexibility with higher external static pressure for powerful ducted air conditioning that preserves interior decor.



High static pressure of 200 Pa or higher

The additional external static pressure capacity provides flexibility for duct extension, branching and air outlet configuration.

PEFY-P VMH-E		P40	P50	P63	P71	P80	P100	P125	P140	P200	P250
External static pressure (Pa)	220V	50/100/200									—
	230/240V	100/150/200									—
	380V	—									110/220
	400/415V	—									130/260

PEFY-P VMHS-E	P200	P250
External static pressure (Pa)	<50> – <100> – 150 – <200> – <250>*	

*The rated external static pressure is shown without < >.
The factory setting is the rated value.

Reduced noise thanks to the use of newly designed centrifugal fan

Sound pressure level table (Standard static pressure 220V)

Sound pressure Level	Capacity		dB(A)							
	Fan Speed	High	P40	P50	P63	P71	P80	P100	P125	P140
		Low	27	27	32	32	35	34	34	34
		High	34	34	38	39	41	42	42	42
		Low	27	27	32	32	35	34	34	34

One-side maintenance

All maintenance to the unit, including fan inspection and fan motor removal, can be conducted from the inspection opening on one side. (VMH model only)

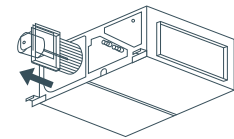

Drain pump (option) ensures up to 550mm (21-11/16in.) for VMH model / 700mm (27-9/16in.) for VMHS model of lift

The introduction of an upper drain pump allows the drain connection to be raised as high as 550mm(21-11/16in.) for VMH model/700mm (27-9/16in.) for VMHS model, allowing more freedom in piping layout design and reducing horizontal piping requirements.

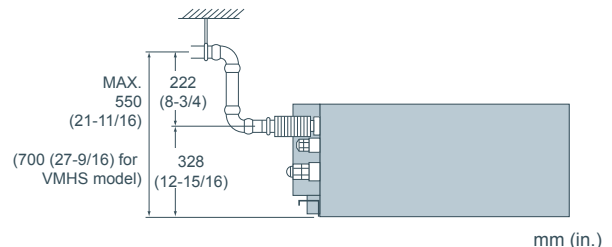

► Specifications

		PEFY-P40VMH-E	PEFY-P50VMH-E	PEFY-P63VMH-E	PEFY-P71VMH-E	PEFY-P80VMH-E	PEFY-P100VMH-E	PEFY-P125VMH-E	PEFY-P140VMH-E	
Power source		1-phase 220-240V 50Hz / 1-phase 220-240V 60Hz								
Cooling capacity	*1 kW	4.5	5.6	7.1	8.0	9.0	11.2	14.0	16.0	
	*1 BTU/h	15,400	19,100	24,200	27,300	30,700	38,200	47,800	54,600	
Heating capacity	*1 kW	5.0	6.3	8.0	9.0	10.0	12.5	16.0	18.0	
	*1 BTU/h	17,100	21,500	27,300	30,700	34,100	42,700	54,600	61,400	
Power consumption	Cooling kW	0.19 / 0.23		0.24 / 0.30	0.26 / 0.33	0.32 / 0.40	0.48 / 0.58		0.48 / 0.59	
	Heating kW	0.19 / 0.23		0.24 / 0.30	0.26 / 0.33	0.32 / 0.40	0.48 / 0.58		0.48 / 0.59	
Current	Cooling A	0.88 / 1.06		1.12 / 1.38	1.20 / 1.51	1.47 / 1.83	2.34 / 2.66		2.35 / 2.70	
	Heating A	0.88 / 1.06		1.12 / 1.38	1.20 / 1.51	1.47 / 1.83	2.34 / 2.66		2.35 / 2.70	
External finish		Galvanized								
Dimension H x W x D	mm	380 x 750 x 900			380 x 1,000 x 900			380 x 1,200 x 900		
	in.	15 x 29-9/16 x 35-7/16			15 x 39-3/8 x 35-7/16			15 x 47-1/4 x 35-7/16		
Net weight	kg(lbs.)	44 (98)	45 (100)		50 (111)		70 (155)			
Heat exchanger		Cross fin (Aluminum plate fin and copper tube)								
Fan	Type x Quantity		Sirocco fan x 1				Sirocco fan x 2			
	Airflow rate (Lo-Hi)	m ³ /min	10.0-14.0		13.5-19.0	15.5-22.0	18.0-25.0	26.5-38.0		28.0-40.0
		L/s	167-233		225-317	258-367	300-417	442-633		467-667
		cfm	353-494		477-671	547-777	636-883	936-1342		989-1413
	External static pressure *2	220V Pa	50 · 100 · 200							
230,240V Pa		100 · 150 · 200								
Motor		1-phase induction motor								
Output	*3 kW	0.08		0.12	0.14	0.18	0.26			
Air filter (option)		Synthetic fiber unwoven cloth filter (long life)								
Refrigerant pipe diameter	Gas (Flare) mm(in.)	ø12.7 (ø1/2)			ø15.88 (ø5/8)					
	Liquid (Flare) mm(in.)	ø6.35 (ø1/4)			ø9.52 (ø3/8)					
Field drain pipe diameter	mm(in.)	O.D. 32 (1-1/4)								
Sound pressure level (Lo-Hi) *6	220V dB(A)	27-34		32-38	32-39	35-41	34-42			
	230,240V dB(A)	31-37		36-41	35-41	38-43	38-44			

		PEFY-P200VMHS-E	PEFY-P250VMHS-E	
Power source		1-phase 220-240V 50Hz / 1-phase 220-240V 60Hz		
Cooling capacity	*1 kW	22.4		
	*1 BTU/h	76,400		
Heating capacity	*1 kW	25.0		
	*1 BTU/h	85,300		
Power consumption	Cooling kW	0.63 *7		
	Heating kW	0.63 *7		
Current	Cooling	380-415V A	—	
		220-230-240V A	3.47-3.32-3.18 *7	
	Heating	380-415V A	—	
		220-230-240V A	3.47-3.32-3.18 *7	
External finish		Galvanized steel plate		
Dimension H x W x D	mm	470 x 1,250 x 1,120		
	in.	18-9/16 x 49-1/4 x 44-1/8		
Net weight	kg(lbs.)	97 (214)	100 (221)	
Heat exchanger		Cross fin (Aluminum plate fin and copper tube)		
Fan	Type x Quantity		Sirocco fan x 2	
	Airflow rate	m ³ /min	—	
		L/s	—	
		cfm	—	
	Lo-Mid-Hi	m ³ /min	50.0-61.0-72.0	
		L/s	833-1017-1200	
		cfm	1766-2154-2542	
External static pressure	380V Pa	—		
	400,415V Pa	—		
	Pa	<50>-<100>-150-<200>-<250> *8		
mmH ₂ O		<5.1>-<10.2>-15.3-<20.4>-<25.5> *8		
Motor		DC motor		
Output	kW	0.87	0.87	
Air filter(option)		Synthetic fiber unwoven cloth filter (long life filter) and filter box are recommended.		
Refrigerant pipe diameter	Gas (Brazed) mm(in.)	ø19.05 (ø3/4)		
	Liquid (Brazed) mm(in.)	ø9.52 (ø3/8)		
Field drain pipe diameter	mm(in.)	O.D. 32 (1-1/4)		
Sound pressure level	380V dB(A)	—		
	400,415V dB(A)	—		
	Lo-Mid-Hi dB(A)	36-39-43 *9		
		39-42-46 *9		

Notes:

- *1 Cooling/heating capacity indicates the maximum value at operation under the following condition.
Cooling Indoor : 27°C(81°F)DB/19°C(66°F)WB, Outdoor : 35°C(95°F)DB
Heating Indoor : 20°C(68°F)DB, Outdoor : 7°C(45°F)DB/6°C(43°F)WB
- *2 The external static pressure is set to 100Pa (at 220V) /150Pa (at 230, 240V) at factory shipment.
- *3 The value are that at 240V.
- *4 The external static pressure is set to 220Pa (at 380V) /260Pa (at 400, 415V) at factory shipment.
- *5 The value are that at 415V.

- *6 It is measured in anechoic room.
- *7 The values are measured at the rated external static pressure.
- *8 The rated external static pressure is shown without < > .
The factory setting is the rated value.
- *9 It is measured at the rated external static pressure in anechoic room.

INDOOR UNIT Fresh Air Intake Type

PEFY-P VMH-E-F

Fresh Air Intake

Fresh Air can be taken in with temperature control. Ideal for offices, stores and restaurants.



The Fresh Air intake indoor unit can be installed anywhere.

The Fresh Air intake indoor unit can take fresh outdoor air into any building in any place.

Office, Lobby, Workshop, Rest room, Nursing home, Cafeterias, Restaurant Kitchen

*** Limits of capacity connectable to outdoor unit**
Max. 110% of outdoor unit capacity, excepting heating at outdoor temperature of less than -5°C(23°F) (100%).

Example

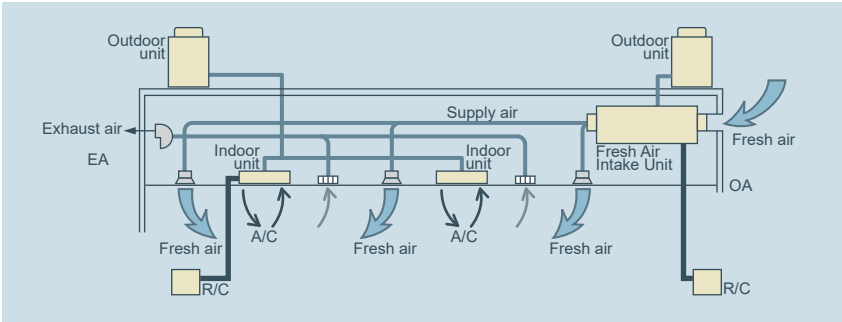

< Note >

Fan remains in operation during Thermo-OFF. Using this model with other types of indoor units is recommended to prevent cold drafts caused by intaken fresh air.

< Note >

Please contact your local sales engineer for specific installation and application information relating to this product.



► Specifications

		PEFY-P80VMH-E-F		PEFY-P140VMH-E-F		
Power source		1-phase 220-240V 50Hz / 1-phase 208-230V 60Hz				
Cooling capacity	*1	kW	9.0	16.0		
	*1	BTU/h	30,700	54,600		
Heating capacity	*1	kW	8.5	15.1		
	*1	BTU/h	29,000	51,500		
Power consumption	Cooling	kW	0.16 / 0.21	0.29 / 0.33		
	Heating	kW	0.16 / 0.21	0.29 / 0.33		
Current	Cooling	A	0.67 / 0.91	1.24 / 1.48		
	Heating	A	0.67 / 0.91	1.24 / 1.48		
External finish		Galvanized				
Dimension H x W x D		mm(in.)	380 x 1000 x 900 (15 x 39-3/8 x 35-7/16)	380 x 1200 x 900 (15 x 47-1/4 x 35-7/16)		
Net weight		kg(lbs.)	50 (111)	70 (155)		
Heat exchanger		Cross fin (Aluminum plate fin and copper tube)				
Fan	Type x Quantity		Sirocco fan x 1		Sirocco fan x 2	
	Airflow rate	m ³ /min	9.0	18.0		
		L/s	150	300		
		cfm	318	636		
	External static pressure (Lo-Mid-Hi)	208V	Pa	35 - 85 - 170	35 - 85 - 170	
		220V	Pa	40 - 115 - 190	50 - 115 - 190	
230V		Pa	50 - 130 - 210	60 - 130 - 220		
240V		Pa	80 - 170 - 220	100 - 170 - 240		
Motor		1-phase induction motor				
Output		kW	0.09 (at 220V)	0.14 (at 220V)		
Air filter (option)		Synthetic fiber unwoven cloth filter (long life)				
Refrigerant pipe diameter	Gas (Flare)	mm(in.)	ø15.88 (ø5/8)			
	Liquid (Flare)	mm(in.)	ø9.52 (ø3/8)			
Field drain pipe diameter		mm(in.)	O.D.32 (1-1/4)			
Sound pressure level (Lo-Mid-Hi) *2	208, 220V	dB(A)	27 - 38 - 43	28 - 38 - 43		
	230, 240V	dB(A)	33 - 43 - 45	34 - 43 - 45		

		PEFY-P200VMH-E-F		PEFY-P250 VMH-E-F		
Power source		3-phase 380-415V 50Hz / 3N~ 380-415V 60Hz				
Cooling capacity		kW	22.4	28.0		
		BTU/h	76,400	95,500		
Heating capacity		kW	21.2	26.5		
		BTU/h	72,300	90,400		
Power consumption	Cooling	kW	0.34 / 0.42	0.39 / 0.50		
	Heating	kW	0.34 / 0.42	0.39 / 0.50		
Current	Cooling	A	0.58 / 0.74	0.68 / 0.86		
	Heating	A	0.58 / 0.74	0.68 / 0.86		
External finish		Galvanized				
Dimension H x W x D		mm(in.)	470 x 1250 x 1120 (18-9/16 x 49-1/4 x 44-1/8)			
Net weight		kg(lbs.)	100 (221)			
Heat exchanger		Cross fin (Aluminum plate fin and copper tube)				
Fan	Type x Quantity		Sirocco fan x 2			
	Airflow rate	m ³ /min	28	35		
		L/s	467	583		
		cfm	989	1236		
	External static pressure	380V	Pa	140 / 200	110 / 190	
		400V	Pa	150 / 210	120 / 200	
415V		Pa	160 / 220	130 / 210		
Motor		3-phase induction motor				
Output		kW	0.20	0.23		
Air filter (option)		Synthetic fiber unmoven cloth filter (long life type)				
Refrigerant pipe diameter	Gas (Flare)	mm(in.)	ø19.05 (ø3/4)	ø22.2 (ø7/8)		
	Liquid (Flare)	mm(in.)	ø9.52 (ø3/8)			
Field drain pipe diameter		mm(in.)	O.D.32 (1-1/4)			
Sound pressure level *2	380V	dB(A)	39 / 42	40 / 44		
	400V	dB(A)	40 / 43	40 / 45		
	415V	dB(A)	40 / 44	41 / 46		

Notes:

- The cooling and heating capacities are the maximum capacities that were obtained by operating in the above air conditions and with a refrigerant pipe of about 7.5m.
- The actual capacity characteristics vary with the combination of indoor and outdoor units. See the technical information.
- The operating noise is the data that was obtained by measuring it 1.5m from the bottom of the unit in an anechoic room. (Noise meter A-scale value)
- The figure of Electrical characteristic indicates at 240V 50Hz/230V60Hz (PEFY-P80, 140VMH-E-F type), at 220Pa setting at 415V (PEFY-P200, 250VMH-E-F type).
- When the 100% fresh air indoor units are connected, the maximum connectable indoor units to 1 outdoor unit are as follows

Heat pump models	Cooling only
110%(100% in case of heating below-5°C(23°F))	110%

- Operational temp range is (Cooling : from 21°C(70°F)DB/15.5°C(60°F)WB to 43°C(109°F)DB/35°C(95°F)WB)
(Heating : from -10°C(14°F)DB to 20°C(68°F)DB)

- * Thermo off(Fan) operation automatically starts either when temperature is lower than 21°C(70°F)DB in cooling mode or when the temperature exceeds 20°C(68°F)DB in heating mode.
- As the room temp in sensed by the thermo in the remote controller or the one in the room, be sure to use either remote controller or room thermo.
 - Autochangeover function or Dry mode is NOT available. Fan mode operation during the thermo off in Cooling/Heating mode.
 - In any case, the air flow rate should be kept lower than 110% of the above chart. Please see "Fan curves" for the details.
 - When this unit is used as sole A/C system, be careful about the dew in air outlet grilles in cooling mode.
 - Un-conditioned outdoor air such as humid air or cold air blows to the indoor during thermo off operation.
Please be careful when positioning indoor unit air outlet grilles, ie take the necessary precautions for cold air, and also insulate rooms for dew condensation prevention as required.
 - Air filter must be installed in the air intake side. The filter should be attached where easy maintenance is possible in case of usage of filed supply filters.
 - Long life cannot be used with Hi-efficiency filter together (PEFY-P80 · 140VMH-E-F type).

INDOOR UNIT Under Ceiling Unit

PCFY-P VKM-E



Designed for ultra-quiet operation and easy maintenance, providing exceptional comfort.



Extra slim, extra stylish

Sleek and slim with stylishly curved lines, the PCFY series blends right into any interior. It also features a single air outlet which allows the auto vane to act as a shutter when the unit is turned off.

Auto vane distributes air evenly

The auto vane swings up and down automatically to distribute air more evenly to every corner of the room.

Long life filter as standard

Long life filter is equipped as standard enabling up to 2,500 hours of operation (office use) without maintenance.

Keeps airflow at optimum level according to ceiling height

The most suitable airflow can be selected for ceilings up to 4.2m high, enhancing air-conditioning efficiency and comfort. (P100/P125)

	Standard	High ceiling
Ceiling height	3.0(9-13/16)	4.2(13-3/4)

m (ft)

Greatly simplified installation

The direct suspension system eliminates the task of removing the attachment fixture from the main unit, greatly shortening installation time.

Drain pump option available with all models

The pumping height of the optional drain pump has been increased from 400 mm to 600 mm, expanding flexibility in choosing unit location during installation work.

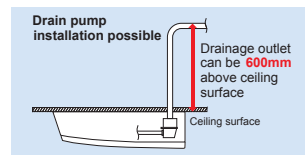

Outside-air intake

Units are equipped with a knock-out hole that enables the induction of fresh outside-air.

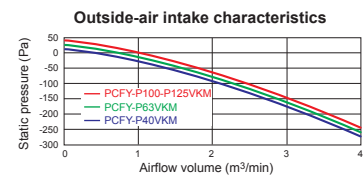

Equipped with automatic air-speed adjustment

In addition to the conventional 4-speed setting, units are now equipped with an automatic air-speed adjustment mode. This setting automatically adjusts the air-speed to conditions that match the room environment. At the start of heating/cooling operation, the airflow is set to high-speed to quickly heat/cool the room. When the room temperature reaches the desired setting, the airflow speed is decreased automatically for stable heating/cooling operation and comfort.

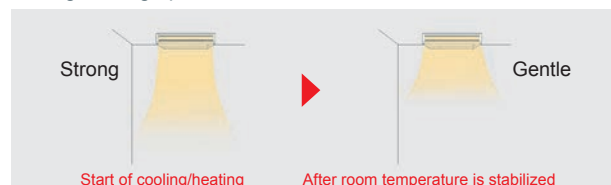

► Specifications

			PCFY-P40VKM-E	PCFY-P63VKM-E	PCFY-P100VKM-E	PCFY-P125VKM-E
Power source			1-phase 220-240V 50Hz / 1-phase 220V 60Hz			
Cooling capacity	*1	kW	4.5	7.1	11.2	14.0
	*1	BTU/h	15,400	24,200	38,200	47,800
Heating capacity	*1	kW	5.0	8.0	12.5	16.0
	*1	BTU/h	17,100	27,300	42,700	54,600
Power consumption	Cooling	kW	0.04	0.05	0.09	0.11
	Heating	kW	0.04	0.05	0.09	0.11
Current	Cooling	A	0.28	0.33	0.65	0.76
	Heating	A	0.28	0.33	0.65	0.76
External finish(Munsell No.)			6.4Y 8.9/ 0.4			
Dimension H x W x D	mm		230 x 960 x 680	230 x 1,280 x 680	230 x 1,600 x 680	
	in.		9-1/16 x 37-13/16 x 26-3/4	9-1/16 x 50-3/8 x 26-3/4	9-1/16 x 63 x 26-3/4	
Net weight		kg(lbs.)	24(53)	32 (71)	36 (79)	38 (84)
Heat exchanger			Cross fin (Aluminum fin and copper tube)			
Fan	Type x Quantity		Sirocco fan x 2	Sirocco fan x 3	Sirocco fan x 4	
	Airflow rate *2 (Lo-Mid2-Mid1-Hi)	m ³ /min	10-11-12-13	14-15-16-18	21-24-26-28	21-24-27-31
		L/s	167-183-200-217	233-250-267-300	350-400-433-467	350-400-450-517
		cfm	353-388-424-459	494-530-565-636	742-847-918-989	742-847-953-1,095
External static pressure		Pa	0			
Motor			DC motor			
Output		kW	0.090	0.095	0.160	
Air filter			PP Honeycomb (long life)			
Refrigerant pipe diameter	Gas (Flare)	mm(in.)	ø12.7 (ø1/2)	ø15.88 (ø5/8)	ø15.88 (ø5/8) / ø19.05 (ø3/4) (Compatible)	
	Liquid (Flare)	mm(in.)	ø6.35 (ø1/4)	ø9.52 (ø3/8)		
Field drain pipe diameter		mm(in.)	O.D. 26 (1)			
Sound pressure level (Lo-Mid2-Mid1-Hi) *2 *3		dB(A)	29-32-34-36	31-33-35-37	36-38-41-43	36-39-42-44

Notes:

- *1 Cooling/Heating capacity indicates the maximum value at operation under the following condition.
Cooling Indoor : 27°C(80.6°F)DB/19°C(66.2°F)WB, Outdoor 35°C(95°F)DB
Heating Indoor : 20°C(68°F)DB, Outdoor 7°C(44.6°F)DB/6°C(42.8°F)WB
- *2 Airflow rate/Sound pressure level are shown in (low-middle 2-middle 1-high).
- *3 It is measured in anechoic room.

INDOOR UNIT Wall Mounted Type

PKFY-P VBM-E PKFY-P VHM-E PKFY-P VKM-E



PKFY-P VBM



PKFY-P VHM



PKFY-P VKM

Elegant design and compact dimensions ideal for offices, stores and residential uses.



Capacity range

Capacity	P15	P20	P25	P32	P40	P50	P63	P100
VBM	●	●	●					
VHM				●	●	●		
VKM							●	●

4-way piping provides more flexibility in selecting installation sites

All piping including drainage can be connected from the rear, right, base, and left of the unit, providing much greater flexibility in piping and selecting installation site.

Flat panel & pure white finish

All models have changed from the grill design, adopting the flat panel layout. Pursuing a design that harmonises with virtually any interior, the unit color has been changed from white to pure white.

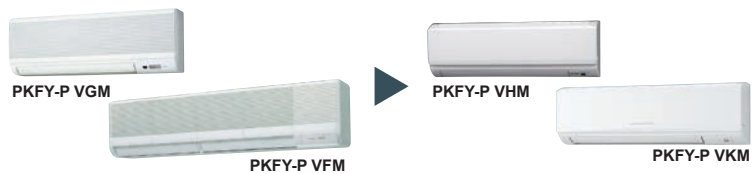

Built-in signal receiver

PKFY-P VBM features

Compact profile

Quiet operation

PKFY-P VHM features

Compact size of 898mm

Width size reduced to match small size buildings and offices.

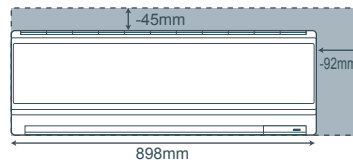

Comparison with PKFY-P VGM-E

Light unit

Approx. 3kg reduced from conventional model (P32-50). Easier installation.

Drain pump (option)

The optional drain pump allows the drain connection to be raised as high as 800mm, allowing more freedom in piping layout design.

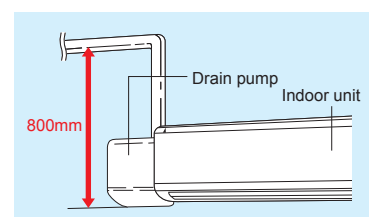

► Specifications

		PKFY-P15VBM-E	PKFY-P20VBM-E	PKFY-P25VBM-E	PKFY-P32VHM-E	PKFY-P40VHM-E	PKFY-P50VHM-E
Power source		1-phase 220-240V 50Hz / 1-phase 220V 60Hz					
Cooling capacity	*1 kW	1.7	2.2	2.8	3.6	4.5	5.6
	*1 BTU/h	5,800	7,500	9,600	12,300	15,400	19,100
Heating capacity	*1 kW	1.9	2.5	3.2	4.0	5.0	6.3
	*1 BTU/h	6,500	8,500	10,900	13,600	17,100	21,500
Power consumption	Cooling *4 kW	0.04			0.04		
	Heating kW	0.04			0.03		
Current	Cooling *4 A	0.20			0.40		
	Heating A	0.20			0.30		
External finish(Munsell No.)		Plastic (1.0Y 9.2/0.2)			Plastic (1.0Y 9.2/0.2)		
Dimension H x W x D		295 x 815 x 225 (11-5/8 x 32-1/8 x 8-7/8)			295 x 898 x 249(11-5/8 x 35-3/8 x 9-13/16)		
Net weight		10 (23)			13(29)		
Heat exchanger		Cross fin (Aluminum fin and copper tube)					
Fan	Type x Quantity		Line flow fan x 1				
	Airflow rate *2 (Lo-Mid2-Mid1-Hi)	m ³ /min	4.9-5.0-5.2-5.3	4.9-5.2-5.6-5.9	9-10-11	9-10.5-11.5	9-10.5-12
		L/s	82-83-87-88	82-87-93-98	150-167-183	150-175-192	150-175-200
		cfm	173-177-184-187	173-184-198-208	318-353-388	318-371-406	318-371-424
External static pressure		Pa					
		0					
Motor	Type	1-phase induction motor			DC motor		
	Output	kW			0.030		
Air filter		PP Honeycomb					
Refrigerant pipe diameter	Gas (Flare)	mm(in.)				ø12.7 (ø1/2)	
	Liquid (Flare)	mm(in.)				ø6.35 (ø1/4)	
Field drain pipe diameter		mm(in.)					
		I.D.16 (5/8)					
Sound pressure level (Lo-Mid2-Mid1-Hi) *2 *3		dB(A)	29-31-32-33	29-31-34-36	34-37-41	34-38-41	34-39-43

Notes:

- *1 Cooling/Heating capacity indicates the maximum value at operation under the following condition.
Cooling Indoor : 27°C(81°F)DB/19°C(66°F)WB, Outdoor 35°C(95°F)DB
Heating Indoor : 20°C(68°F)DB, Outdoor 7°C(45°F)DB/6°C(43°F)WB
- *2 Airflow rate/Sound pressure level are in (low-middle2-middle1-high).
- *3 It is measured in anechoic room.
- *4 Electrical characteristic of cooling are included optional drain-pump.

		PKFY-P63VKM-E	PKFY-P100VKM-E
Power source		1-phase 220-230-240V 50Hz / 1-phase 220V 60Hz	
Cooling capacity	*1 kW	7.1	11.2
	*1 BTU/h	24,200	38,200
Heating capacity	*1 kW	8.0	12.5
	*1 BTU/h	27,300	42,600
Power consumption	Cooling *4 kW	0.05	
	Heating kW	0.04	
Current	Cooling *4 A	0.37	
	Heating A	0.30	
External finish(Munsell No.)		Plastic (1.0Y 9.2/0.2)	
Dimension H x W x D		mm(in.)	
		365 x 1,170 x 295 (14-3/8 x 46-1/16 x 11-5/8)	
Net weight		kg(lbs.)	
		21 (46)	
Heat exchanger		Cross fin (Aluminum fin and copper tube)	
Fan	Type x Quantity		Line flow fan x 1
	Airflow rate *2 (Lo-Hi)	m ³ /min	16-20
		L/s	267-333
		cfm	565-706
External static pressure		Pa	
		0	
Motor	Type	DC motor	
	Output	kW	
		0.056	
Air filter		PP Honeycomb	
Refrigerant pipe diameter	Gas (Flare)	mm(in.)	
	Liquid (Flare)	mm(in.)	
Field drain pipe diameter		mm(in.)	
		I.D. 16(5/8)	
Sound pressure level (Lo-Hi) *2 *3		dB(A)	39-45
		dB(A)	41-49

Notes:

- *1 Cooling/heating capacity indicates the maximum value at operation under the following condition.
Cooling Indoor : 27°C(81°F)DB/19°C(66°F)WB, Outdoor : 35°C(95°F)DB
Heating Indoor : 20°C(68°F)DB, Outdoor : 7°C(45°F)DB/6°C(43°F)WB
- *2 Airflow rate/Sound pressure level are in (low-high).
- *3 It is measured in anechoic room.
- *4 Electrical characteristic of cooling are included optional drain-pump.

INDOOR UNIT

Wall Mounted Type



MSZ-EF Designer Series and PAC-LV11M-J External LEV Kit*

An exceptional combination of energy efficiency and award winning design, the Designer Series will appeal to those with even the most discerning style.

Three Colours Available

The Designer Series has a slimline profile, and a flat panel façade. Available in glossy white, matte silver or rich black diamond, the Designer Series will suit any application. The Designer Series is an unobtrusive, efficient, and safe heating source which allows you to make the most of valuable floor space.

Superior Filtration

Equipped with a nano-platinum filter which is both antibacterial and deodorising, the filter ensures increased dust catchment and superior air cleaning.

► Specifications

		MSZ-EF25VEW/B/S	MSZ-EF35VEW/B/S	MSZ-EF42VEW/B/S	MSZ-EF50VEW/B/S
Power source		Single phase 230 V, 50 Hz			
Cooling Capacity	kW	2.5	3.5	4.2	5
	BTU/h	8,530	11,942	14,330	17,060
Heating Capacity	kW	3.2	4	5.4	5.8
	BTU/h	10,918	13,648	18,425	19,790
Power Consumption	Cooling kW	0.014			0.018
	Heating kW	0.027	0.031		0.034
Current	Cooling A	0.14	0.14	0.14	0.18
	Heating A	0.26	0.3	0.3	0.32
External finish		Classic White, Matte Silver, Glossy Black			
Dimensions (WxDxH)		[mm] 895 x 195 x 299			
Net weight		[kg] 11.5			
Heat exchanger		Cross fin (Aluminum fin and copper tube)			
Fan	Type x Quantity	Line flow fan x 1			
	Airflow rate Cooling (Lo-SHi) m3/min	4.6-6.3-8.15-10.5		6.6-7.7-8.9-10.3	6.8-7.9-9.3-11
	Airflow rate Heating(Lo-SHi) m3/min	4.6-6.2-8.9-11.9	4.6-6.2-8.9-12.7	6.3-7.8-9.9-12.7	7.3-9-11.1-13.7
	External static pressure Pa	N/A			
Motor	Type	RC0J40 - DC motor			
	Output (C/H) kW	0.014/0.027	0.014/0.031	0.014/0.031	0.018/0.034
Air filter		Nano Platinum			
Refrigerant pipe diameter	Gas (flare) mm	9.52			12.7
	Liquid (flare) mm	6.35			
Field drain pipe diameter		I.D. 15mm			
"Sound pressure level (Lo-Mid-Hi-Shi)"		dBA 23-29-36-42	24-29-36-42	31-35-39-42	33-36-40-43

*A PAC-LV11M-J is required for each MSZ-EF indoor unit installed.

CITY MULTI External LEV Kit for Designer Series High Walls

PAC-LV11M-J

Feature

- Connection between CITY MULTI and Designer Series high walls
- Wider indoor unit selection options
- Controllable from MELANS controller
- Compact size 183 x 355 x 142 mm (H x W x D)
- Maximum distance of 15 m between Connection KIT and RAC Indoor unit
- No need for drain pipe

Specifications

MODEL		PAC-LV11M-J	
Power source		Single / 220-240V / 50Hz	
Connectable number of indoor unit		1	
External finish		Galvanized steel sheet (No external finish)	
External dimension H x W x D		mm	183 x 355 x 142
Net weight		kg	3.5
Refrigerant piping diameter	Liquid pipe	mm	6.35 Brazed
	Gas pipe	mm	-
Wiring		To Outdoor unit	2-core shield cable

System Structure

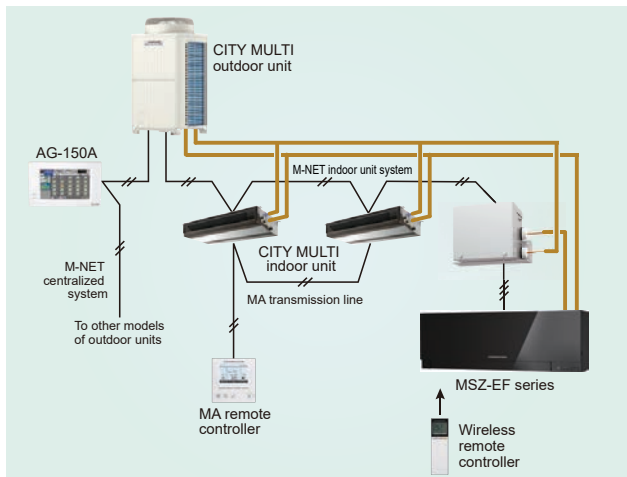

*Refer to the relevant manuals for detailed information and restrictions.

External Dimensions

Unit : mm

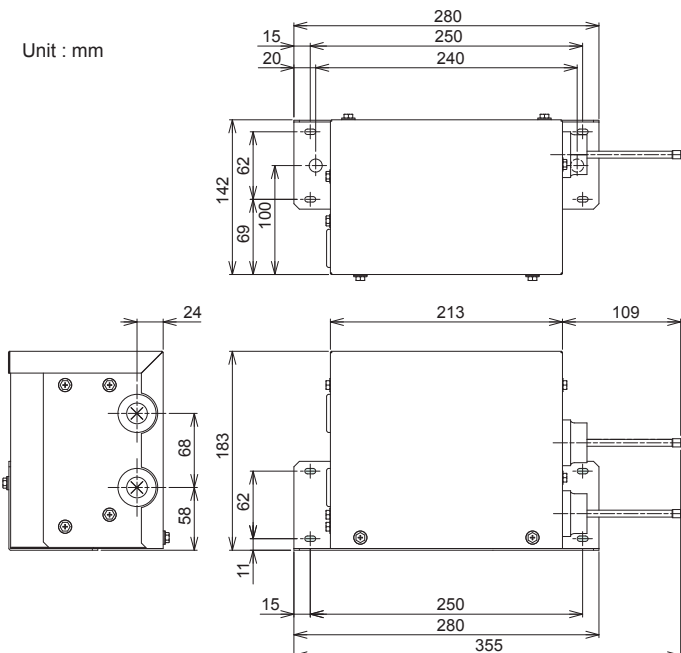

Connectable Models

Outdoor Unit
PUHY Series
PURY Series

Indoor Unit
MSZ-EF Series



Refrigerant Circuit Diagrams

The gas pipe sensor (packaged, field installed) and the built-in sensor on the RAC units allow for optimum control of the LEV.

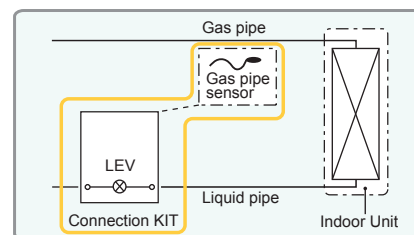

INDOOR UNIT Floor Console

PFFY-P VKM-E2



For living rooms, bedrooms, or offices where a sophisticated design is required. The latest Mitsubishi Electric innovation – floor-standing air-conditioners sophisticated in design, rich in function.



Quiet operation

Mitsubishi Electric air conditioners have always been some of the quietest models available in the market. Our new floor-standing models are no exception. Floor consoles create a quiet, comfortable space and are designed for unobtrusive heating.

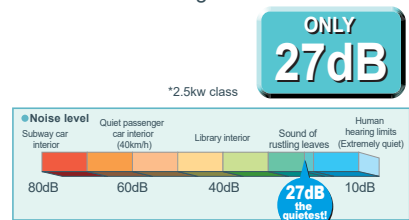

Sophisticated Design

From Mitsubishi Electric, an innovative new floor-standing air-conditioner, a mix of streamlined form and diversified

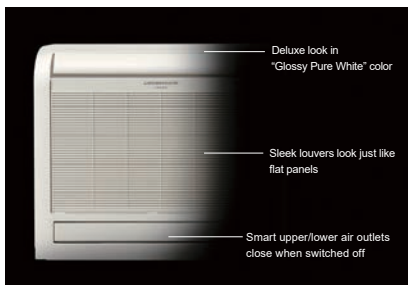

function. Engineered to keep walls free and allowing for comfortable cooling in summer and toasty heating in winter, the "Glossy Pure White" colour ensures a deluxe look, the perfect match for any room. Both upper and lower air outlets remain closed when switched OFF, for a smart and striking look. A superb new air-conditioner from Mitsubishi Electric, providing a handsome fit for your own distinctive interior.

Slim but Mighty

The unit's body is slim and compact; an ideal size for living rooms, bedrooms, and more. The removable and washable front panel makes cleaning a snap. Easy and regular cleaning means your air-conditioner stays pristine while maintaining energy-efficient operation.

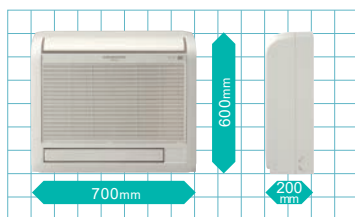

Optimum Air Distribution

Comfortable room temperatures are realised by the optimum, powerful and efficient air distribution through upper and lower air outlets. The upper vane angle is remote controllable, with 5 air flow direction levels (+Swing and Auto modes) and 4 wind power levels (+Auto mode).

By setting the vane angle almost vertical, direct air flow can be avoided for increased comfort.

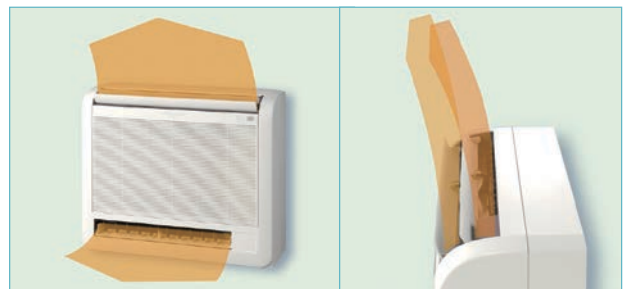

The air from both upper and lower air outlets is optimally controlled and distributed evenly to every corner of the room. In heating mode, the warm air is smartly controlled to stay at the floor level, meaning your feet will never feel chilled again!

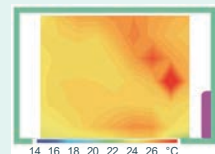

► Specifications

		PFFY-P20VKM-E2	PFFY-P25VKM-E2	PFFY-P32VKM-E2	PFFY-P40VKM-E2
Power source		1-phase 220-240V 50Hz			
Cooling capacity	*1 kW	2.2	2.8	3.6	4.5
	*1 BTU/h	7,500	9,600	12,300	15,400
Heating capacity	*1 kW	2.5	3.2	4.0	5.0
	*1 BTU/h	8,500	10,900	13,600	17,100
Power consumption	Cooling kW	0.025	0.025	0.025	0.028
	Heating kW	0.025	0.025	0.025	0.028
Current	Cooling A	0.20	0.20	0.20	0.24
	Heating A	0.20	0.20	0.20	0.24
External finish		Plastic (Pure white)			
Dimension		600 x 700 x 200			
H x W x D		in. 23-5/8 x 27-9/16 x 7-7/8			
Net weight		kg(lbs.) 15 (34)			
Heat exchanger		Cross fin (Aluminium plate fin and copper tube)			
Fan	Type x Quantity	Line flow fan x 2			
	Airflow rate (Lo-Mid-Hi-SHi)	m ³ /min 5.9-6.8-7.6-8.7	6.1-7.0-8.0-9.1	6.1-7.0-8.0-9.1	8.0-9.0-9.5-10.7
	External static pressure	Pa 0			
Motor	Type	DC motor			
	Output	kW 0.03 x 2			
Air filter		PP honeycomb fabric (Catechin Filter)			
Refrigerant pipe diameter	Gas(Flare) mm(in.)	ø12.7 (ø1/2)			
	Liquid(Flare) mm(in.)	ø6.35 (ø1/4)			
Field drain pipe diameter		I.D.16 (5/8)			
Sound pressure level (Lo-Mid-Hi-SHi)	*2 dB(A)	27-31-34-37	28-32-35-38	28-32-35-38	35-38-42-44

Notes:

*1 Cooling/heating capacity indicates the maximum value at operation under the following condition.

Cooling Indoor : 27°C(81°F)DB/19°C(66°F)WB, Outdoor : 35°C(95°F)DB

Heating Indoor : 20°C(68°F)DB, Outdoor : 7°C(45°F)DB/6°C(43°F)WB

*2 Airflow rate/Sound pressure level are in (low-middle-high-shigh).

*3 It is measured in anechoic room.

INDOOR UNIT

Floor Standing Exposed

PFFY-P VLEM-E



Floor mounted exposed type, effective for perimeter installation.



- Standardised design with clean lines
- Supports various types of spaces from office buildings and shop buildings to hospitals
- Water vapor permeable film humidifier can be installed
- Remote controller can be installed onto the main unit

Compact unit for easy air conditioning in a perimeter zone

The compact body of 220mm(8-11/16in.) in depth can be easily installed in the perimeter zone for effective, unobtrusive air conditioning.

► Specifications

			PFFY-P20VLEM-E	PFFY-P25VLEM-E	PFFY-P32VLEM-E	PFFY-P40VLEM-E	PFFY-P50VLEM-E	PFFY-P63VLEM-E	
Power source			1-phase 220-240V 50Hz / 1-phase 208-230V 60Hz						
Cooling capacity	*1	kW	2.2	2.8	3.6	4.5	5.6	7.1	
	*1	BTU/h	7,500	9,600	12,300	15,400	19,100	24,200	
Heating capacity	*1	kW	2.5	3.2	4.0	5.0	6.3	8.0	
	*1	BTU/h	8,500	10,900	13,600	17,100	21,500	27,300	
Power consumption	Cooling	kW	0.04 / 0.06		0.06 / 0.07	0.065 / 0.075	0.085 / 0.09	0.1 / 0.11	
	Heating	kW	0.04 / 0.06		0.06 / 0.07	0.065 / 0.075	0.085 / 0.09	0.1 / 0.11	
Current	Cooling	A	0.19 / 0.25		0.29 / 0.30	0.32 / 0.33	0.40 / 0.41	0.46 / 0.47	
	Heating	A	0.19 / 0.25		0.29 / 0.30	0.32 / 0.33	0.40 / 0.41	0.46 / 0.47	
External finish(Munsell No.)			Acrylic paint (5Y 8/1)						
Dimension H x W x D	mm		630 x 1,050 x 220			630 x 1,170 x 220		630 x 1,410 x 220	
	in.		24-13/16 x 41-3/8 x 8-11/16			24-13/16 x 46-1/8 x 8-11/16		24-13/16 x 55-9/16 x 8-11/16	
Net weight		kg(lbs.)	23 (51)		25 (56)	26 (58)	30 (67)	32 (71)	
Heat exchanger			Cross fin (Aluminum plate fin and copper tube)						
Fan	Type x Quantity		Sirocco fan x 1			Sirocco fan x 2			
	Airflow rate (Lo-Hi)	*2	m ³ /min	5.5-6.5		7.0-9.0	9.0-11.0	12.0-14.0	12.0-15.5
		L/s	92-108		117-150	150-183	200-233	200-258	
		cfm	194-230		247-318	318-388	424-494	424-547	
External static pressure		Pa	0						
Motor	Type		1-phase induction motor						
	Output		kW	0.015	0.018	0.030	0.035	0.050	
Air filter			PP Honeycomb fabric (washable)						
Refrigerant pipe diameter	Gas (Flare)	mm(in.)	ø12.7 (ø1/2)					ø15.88 (ø5/8)	
	Liquid (Flare)	mm(in.)	ø6.35 (ø1/4)					ø9.52 (ø3/8)	
Field drain pipe diameter		mm(in.)	I.D.26 (1) <Accessory hose O.D.27 (1-3/32) (top end :20 (13/16))>						
Sound pressure level (Lo-Hi)		*2 *3 *4	34-40		35-40	38-43		40-46	

Notes:

- *1 Cooling/Heating capacity indicates the maximum value at operation under the following condition.
Cooling Indoor : 27°C(81°F)DB/19°C(66°F)WB, Outdoor 35°C(95°F)DB
Heating Indoor : 20°C(68°F)DB, Outdoor 7°C(45°F)DB/6°C(43°F)WB
- *2 Air flow rate/Sound pressure level are in (Low-High)
- *3 Measured point : 1m x 1m, Power supply : AC240V/50Hz
· 1dB(A) lower at AC230V/50Hz
· 2dB(A) lower at AC220V/50Hz
· 3dB(A) lower at 1.5m x 1.5m point
- *4 It is measured in anechoic room.

INDOOR UNIT

Floor Mounted Concealed Type

PFFY-P VLRM-E

PFFY-P VLRMM-E



Neatly installed with pericover concealed.
Easy installation in perimeter zone.

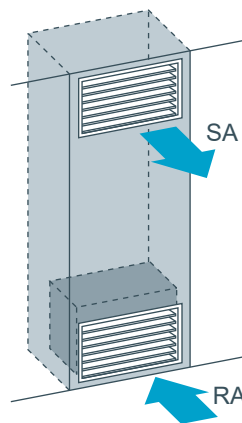

installation image
(PFFY-P VLRMM-E)

Compact unit for easy air conditioning in a perimeter zone

The body is concealed in the pericover to pursue harmony with the interior.

The compact body of 220mm(8-11/16in.) in depth can be easily installed in a perimeter zone.

Maximum external static pressure 60Pa (VLRMM model)

The additional external static pressure capacity provides flexibility for duct extension, branching, and air outlet configuration.

► Specifications

		PFFY-P20VLRM-E	PFFY-P25VLRM-E	PFFY-P32VLRM-E	PFFY-P40VLRM-E	PFFY-P50VLRM-E	PFFY-P63VLRM-E	
Power source		1-phase 220-240V 50Hz / 1-phase 208-230V 60Hz						
Cooling capacity	*1 kW	2.2	2.8	3.6	4.5	5.6	7.1	
	*1 BTU/h	7,500	9,600	12,300	15,400	19,100	24,200	
Heating capacity	*1 kW	2.5	3.2	4.0	5.0	6.3	8.0	
	*1 BTU/h	8,500	10,900	13,600	17,100	21,500	27,300	
Power consumption	Cooling kW	0.04 / 0.06		0.06 / 0.07	0.065 / 0.075	0.085 / 0.09	0.1 / 0.11	
	Heating kW	0.04 / 0.06		0.06 / 0.07	0.065 / 0.075	0.085 / 0.09	0.1 / 0.11	
Current	Cooling A	0.19 / 0.25		0.29 / 0.30	0.32 / 0.33	0.40 / 0.41	0.46 / 0.47	
	Heating A	0.19 / 0.25		0.29 / 0.30	0.32 / 0.33	0.40 / 0.41	0.46 / 0.47	
External finish(Munsell No.)		Galvanized steel plate						
Dimension H x W x D	mm	639 x 886 x 220		639 x 1,006 x 220		639 x 1,246 x 220		
	in.	25-3/16 x 34-15/16 x 8-11/16		25-3/16 x 39-5/8 x 8-11/16		25-3/16 x 49-1/16 x 8-11/16		
Net weight		kg(lbs.) 18.5 (41)		20 (45)	21 (47)	25 (56)	27 (60)	
Heat exchanger		Cross fin (Aluminum plate fin and copper tube)						
Fan	Type x Quantity	Sirocco fan x 1			Sirocco fan x 2			
	Airflow rate *2 (Lo-Hi)	m ³ /min	5.5-6.5		7.0-9.0	9.0-11.0	12.0-14.0	12.0-15.5
		L/s	92-108		117-150	150-183	200-233	200-258
		cfm	194-230		247-318	318-388	424-494	424-547
External static pressure	Pa	0						
Motor	Type	1-phase induction motor						
	Output kW	0.015		0.018	0.030	0.035	0.050	
Air filter		PP Honeycomb fabric (washable)						
Refrigerant pipe diameter	Gas (Flare) mm(in.)	ø12.7 (ø1/2)					ø15.88 (ø5/8)	
	Liquid (Flare) mm(in.)	ø6.35 (ø1/4)					ø9.52 (ø3/8)	
Field drain pipe diameter		mm(in.) I.D.26 (1) <Accessory hose O.D.27 (1-3/32) (top end :20 (13/16))>						
Sound pressure level (Lo-Hi) *2 *3 *4		dB(A) 34-40		35-40	38-43	40-46		

Notes:

- *1 Cooling/Heating capacity indicates the maximum value at operation under the following condition.
Cooling Indoor : 27°C(81°F)DB/19°C(66°F)WB, Outdoor 35°C(95°F)DB
Heating Indoor : 20°C(68°F)DB, Outdoor 7°C(45°F)DB/6°C(43°F)WB
- *2 Air flow rate/Sound pressure level are in (Low-High)
- *3 Measured point : 1m x 1m, Power supply : AC240V/50Hz
· 1dB(A) lower at AC230V/50Hz
· 2dB(A) lower at AC220V/50Hz
· 3dB(A) lower at 1.5m x 1.5m point
- *4 It is measured in anechoic room.

Floor mounted 60Pa

		PFFY-P20VLRMM-E	PFFY-P25VLRMM-E	PFFY-P32VLRMM-E	PFFY-P40VLRMM-E	PFFY-P50VLRMM-E	PFFY-P63VLRMM-E	
Power source		1-phase 220-240V 50Hz / 1-phase 220-240V 60Hz						
Cooling capacity	*1 kW	2.2	2.8	3.6	4.5	5.6	7.1	
	*1 BTU/h	7,500	9,600	12,300	15,400	19,100	24,200	
Heating capacity	*1 kW	2.5	3.2	4.0	5.0	6.3	8.0	
	*1 BTU/h	8,500	10,900	13,600	17,100	21,500	27,300	
Power consumption	Cooling kW	0.04		0.04	0.05	0.05	0.07	
	Heating kW	0.04		0.04	0.05	0.05	0.07	
Current	Cooling A	0.34		0.38	0.43	0.48	0.59	
	Heating A	0.34		0.38	0.43	0.48	0.59	
External finish(Munsell No.)		Galvanized steel plate						
Dimension H x W x D	mm	639 x 886 x 220		639 x 1,006 x 220		639 x 1,246 x 220		
	in.	25-3/16 x 34-15/16 x 8-11/16		25-3/16 x 39-5/8 x 8-11/16		25-3/16 x 49-1/16 x 8-11/16		
Net weight		kg(lbs.) 18.5 (41)		20 (45)	21 (47)	25 (56)	27 (60)	
Heat exchanger		Cross fin (Aluminum plate fin and copper tube)						
Fan	Type x Quantity	Sirocco fan x 1			Sirocco fan x 2			
	Airflow rate (Lo-Mid-Hi)	m ³ /min	4.5-5.5-6.5		6.5-7.5-9.0	8.0-9.5-11.0	10.0-12.0-14.0	11.0-13.0-15.5
		L/s	75-92-108		108-125-150	133-158-183	167-200-233	183-217-258
		cfm	159-194-230		230-265-318	282-335-388	353-424-494	388-459-547
External static pressure *2	Pa	20/40/60						
Motor	Type	DC motor						
	Output kW	0.096						
Air filter		PP Honeycomb fabric (washable)						
Refrigerant pipe diameter	Gas mm(in.)	ø12.7 (ø1/2) Brazed					ø15.88 (ø5/8) Brazed	
	Liquid mm(in.)	ø6.35 (ø1/4) Brazed					ø9.52 (ø3/8) Brazed	
Field drain pipe diameter		mm(in.) I.D.26 (1) <Accessory hose O.D.27 (1-3/32) (top end :20 (13/16))>						
Sound pressure level (Lo-Mid-Hi) *3	20Pa dB(A)	31-36-40		27-32-37	30-36-40	32-37-41	35-40-44	
	40Pa dB(A)	34-39-42		30-35-41	32-38-42	35-40-44	36-42-47	
	60Pa dB(A)	35-40-43		32-37-42	35-39-44	36-41-45	38-43-48	

Notes:

- *1 Cooling/Heating capacity indicates the maximum value at operation under the following condition.
Cooling Indoor : 27°C(81°F)DB/19°C(66°F)WB, Outdoor 35°C(95°F)DB
Heating Indoor : 20°C(68°F)DB, Outdoor 7°C(45°F)DB/6°C(43°F)WB
pipe length : 7.5m(24-9/16ft) Height difference : 0m(0ft)
- *2 The external static pressure is set to 20Pa at factory shipment.
- *3 The sound pressure level in operation is measured at 1m apart from the front side and the bottom side of the unit in anechoic room.
(Noise meter A-scale value) Connect the duct of 1m in length to the air outlet.

BC CONTROLLER

CMB-P-V-G1
CMB-P-V-GA1
CMB-P-V-HA1
CMB-P-V-GB1
CMB-P-V-HB1

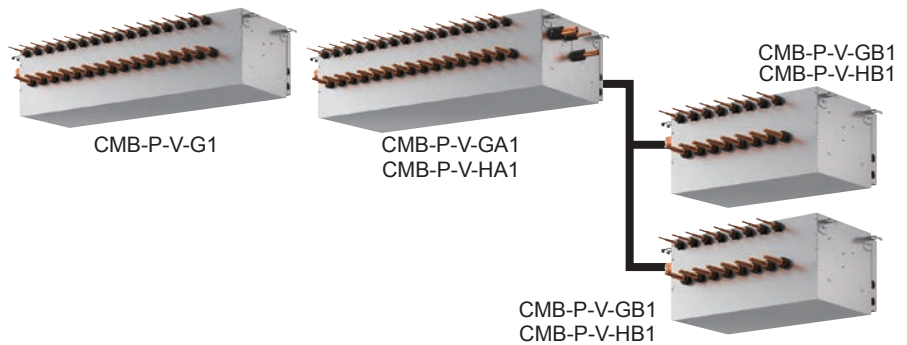

BC CONTROLLER

In many ways, the BC Controller is the technological heart of the CITY MULTI R2/WR2. It works in unison with the outdoor unit to provide simultaneous cooling and heating, something no other two-pipe system can do. The BC Controller is connected to the outdoor unit by two pipes and to each indoor unit by a series of two refrigerant pipes, depending on the indoor unit count. The BC Controller is required for all CITY MULTI R2-Series installations. It comes in 4, 5, 6, 8, 10, 13, and 16-branch options. The BC Controller you select depends on how many indoor units will be operated from each outdoor unit and your total capacity requirements.

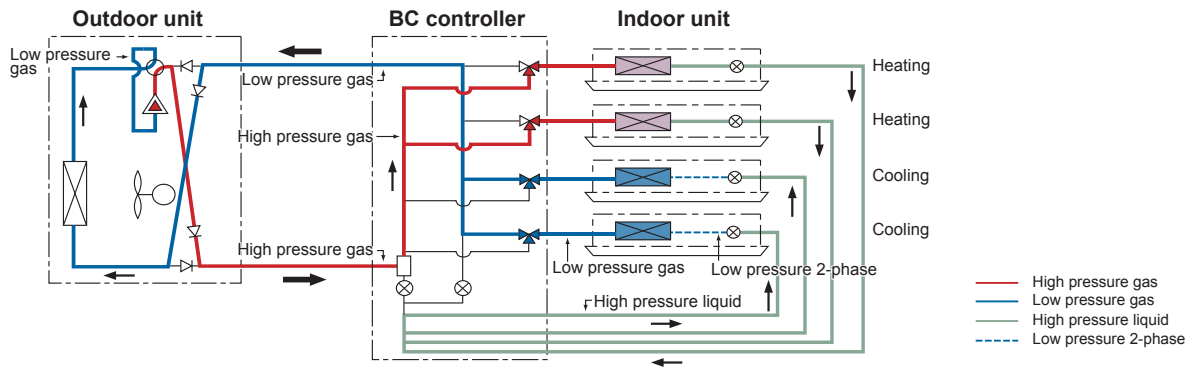

Specifications

PURY-P200 — PURY-P350

Model name		CMB-P104V-G1	CMB-P105V-G1	CMB-P106V-G1	CMB-P108V-G1	CMB-P1010V-G1	CMB-P1013V-G1	CMB-P1016V-G1	
Number of branch		4	5	6	8	10	13	16	
Power source		1-phase 220/230/240V 50Hz/60Hz							
Power input	kW	50Hz	Cooling 0.067/0.076/0.085 heating 0.030/0.034/0.038	0.082/0.093/0.104	0.097/0.110/0.123	0.127/0.144/0.161	0.156/0.177/0.198	0.201/0.228/0.255	0.246/0.279/0.312
		60Hz	Cooling 0.054/0.061/0.067 heating 0.024/0.027/0.030	0.030/0.034/0.038	0.036/0.041/0.045	0.048/0.054/0.060	0.060/0.068/0.075	0.078/0.088/0.097	0.096/0.108/0.119
	A	50Hz	Cooling 0.31/0.34/0.36 heating 0.14/0.15/0.16	0.38/0.41/0.44	0.45/0.48/0.52	0.58/0.63/0.68	0.71/0.77/0.83	0.92/1.00/1.07	1.12/1.22/1.30
		60Hz	Cooling 0.25/0.27/0.28 heating 0.11/0.12/0.13	0.30/0.33/0.35	0.36/0.39/0.41	0.47/0.50/0.53	0.58/0.62/0.65	0.74/0.80/0.84	0.90/0.97/1.03
External finish		Galvanized steel plate (Lower part drain pan painting N1.5)							
Indoor unit capacity connectable to 1 branch		Model P80 or smaller (*Use optional joint pipe combing 2 branches when the total unit capacity exceeds 81.)							
Connectable Outdoor unit ★		Refer to the combination chart of BC controller R2/WR2 series							
Height		mm		284					
Width		mm		648			1098		
Depth		mm		432					
Refrigerant piping diameter	To outdoor unit	Connectable outdoor unit capacity							
		P200		P250, P300		P350			
	High pressure pipe	ø15.88 (ø5/8) Brazed		ø19.05 (ø3/4) Brazed		ø19.05 (ø3/4) Brazed			
	Low pressure pipe	ø19.05 (ø3/4) Brazed		ø22.2 (ø7/8) Brazed		ø28.58 (ø1-1/8) Brazed			
To indoor unit	Liquid pipe	Indoor unit Model 50 or smaller: ø6.35 brazed, Over 50: ø9.52 brazed (ø12.7 with optional joint pipe used.)							
	Gas pipe	Indoor unit Model 50 or smaller: ø12.7 brazed, Over 50: ø15.88 brazed (ø19.05 with optional joint pipe used.)							
Drain pipe		O.D. 32mm							
Net weight		kg	24	27	28	33	38	45	52
Accessories		•Drain connection pipe (with flexible hose and insulation) •Reducer							

Indoor Unit

Specifications

PURY-P200 — PURY-P650

PURY-P700 — PURY-P900

Model name				CMB-P108V-GA1	CMB-P1010V-GA1	CMB-P1013V-GA1	CMB-P1016V-GA1	CMB-P1016V-HA1
Number of branch				8	10	13	16	
Power source				1-phase 220/230/240V 50Hz/60Hz				
Power input	kW	50Hz	Cooling	0.127/0.144/0.161	0.156/0.177/0.198	0.201/0.228/0.255	0.246/0.279/0.312	
			heating	0.060/0.068/0.076	0.075/0.085/0.095	0.097/0.110/0.123	0.119/0.135/0.151	
	60Hz	Cooling	0.102/0.115/0.127	0.126/0.141/0.156	0.162/0.182/0.201	0.198/0.222/0.246		
		heating	0.048/0.054/0.060	0.060/0.068/0.075	0.078/0.088/0.097	0.096/0.108/0.119		
Current	A	50Hz	Cooling	0.58/0.63/0.68	0.71/0.77/0.83	0.92/1.00/1.07	1.12/1.22/1.30	
			heating	0.28/0.30/0.32	0.35/0.37/0.40	0.45/0.48/0.52	0.55/0.59/0.63	
	60Hz	Cooling	0.47/0.50/0.53	0.58/0.62/0.65	0.74/0.80/0.84	0.90/0.97/1.03		
		heating	0.22/0.24/0.25	0.28/0.30/0.32	0.36/0.39/0.41	0.44/0.47/0.50		
External finish				Galvanized steel plate (Lower part drain pan painting N1.5)				
Indoor unit capacity connectable to 1 branch				Model P80 or smaller (*Use optional joint pipe combing 2 branches when the total unit capacity exceeds 81.)				
Connectable Outdoor unit ★				Refer to the combination chart of BC controller R2/WR2 series				
Height		mm		289				
Width		mm		1,110				
Depth		mm		520				
Refrigerant piping diameter	To outdoor unit	Connectable outdoor unit capacity						
		High pressure pipe	P200	P250,300	P350	P400~P500	P550~P650	P700~P800/P850~P900*4
			Ø15.88 (ø5/8) Brazed		Ø19.05 (ø3/4) Brazed		Ø22.2 (ø7/8) Brazed	Ø28.58 (ø1-1/8) Brazed
	Low pressure pipe	Ø19.05 (ø3/4) Brazed	Ø22.2 (ø7/8) Brazed	Ø28.58 (ø1-1/8) Brazed			Ø34.93 (ø1-3/8) Brazed/ Ø41.28 (ø1-5/8) Brazed	
	To indoor unit	Liquid pipe	Indoor unit Model 50 or smaller:Ø6.35 brazed, Over 50:Ø9.52 brazed (Ø12.7 with optional joint pipe used.)					
		Gas pipe	Indoor unit Model 50 or smaller:Ø12.7 brazed, Over 50:Ø15.88 brazed (Ø19.05 with optional joint pipe used.)					
	To another BC controller	Total indoor unit capacity connected to this Sub BC controller						
		~P200		P201~P300	P301~P350	P351~P400	P401~P450	
		High press gas pipe	Ø15.88 (ø5/8) Brazed	Ø19.05 (ø3/4) Brazed		Ø22.2 (ø7/8) Brazed		
		Low press gas pipe	Ø19.05 (ø3/4) Brazed	Ø22.2 (ø7/8) Brazed	Ø28.58 (ø1-1/8) Brazed			
Liquid pipe	Ø9.52 (ø3/8) Brazed			Ø12.7 (ø1/2) Brazed		Ø15.88 (ø5/8) Brazed		
Drain pipe				O.D. 32mm				
Net weight		kg		43	48	55	62	69
Accessories				*Drain connection pipe (with flexible hose and insulation) *Reducer				

Model name				CMB-P104V-GB1	CMB-P108V-GB1	CMB-P1016V-HB1	
Number of branch				4	8	16	
Power source				1-phase 220/230/240V 50Hz/60Hz			
Power input	kW	50Hz	Cooling	0.060/0.068/0.076	0.119/0.135/0.151	0.237/0.269/0.301	
			heating	0.030/0.034/0.038	0.060/0.068/0.076	0.119/0.135/0.151	
	60Hz	Cooling	0.048/0.054/0.060	0.096/0.108/0.119	0.192/0.216/0.237		
		heating	0.024/0.027/0.030	0.048/0.054/0.060	0.096/0.108/0.120		
Current	A	50Hz	Cooling	0.28/0.30/0.32	0.55/0.59/0.63	1.08/1.17/1.26	
			heating	0.14/0.15/0.16	0.28/0.30/0.32	0.55/0.59/0.63	
	60Hz	Cooling	0.22/0.24/0.25	0.44/0.47/0.50	0.88/0.94/0.99		
		heating	0.11/0.12/0.13	0.22/0.24/0.25	0.44/0.47/0.50		
External finish				Galvanized steel plate (Lower part drain pan painting N1.5)			
Indoor unit capacity connectable to 1 branch				Model P80 or smaller (*Use optional joint pipe combing 2 branches when the total unit capacity exceeds 81.)			
Connectable Outdoor unit ★				Refer to the combination chart of BC controller R2/WR2 series			
Height		mm		284			
Width		mm		648			
Depth		mm		432			
Refrigerant piping diameter	To Main BC controller	Total indoor unit capacity connected this Sub BC controller					
		~P200, P201~P350		~P200, P201~P450			
		~P200	P201~P300	P301~P350	P351~P400	P401~P450	
	High pressure pipe	Ø15.88 (ø5/8) Brazed	Ø19.05 (ø3/4) Brazed		Ø22.2 (ø7/8) Brazed		
	Low pressure pipe	Ø19.05 (ø3/4) Brazed	Ø22.2 (ø7/8) Brazed	Ø28.58 (ø1-1/8) Brazed			
	Liquid pipe	Ø9.52 (ø3/8) Brazed		Ø12.7 (ø1/2) Brazed		Ø15.88 (ø5/8) Brazed	
	To indoor unit	Liquid pipe	Indoor unit Model 50 or smaller:Ø6.35 brazed, Over 50:Ø9.52 brazed (Ø12.7 with optional joint pipe used.)				
		Gas pipe	Indoor unit Model 50 or smaller:Ø12.7 brazed, Over 50:Ø15.88 brazed (Ø19.05 with optional joint pipe used.)				
	Drain pipe				O.D. 32mm		
	Net weight		kg		22	32	55
Accessories				*Drain connection pipe (with flexible hose and insulation) *Reducer			

★ Combination chart of BC Controller for R2 series

	P200,250,300,350	P400-650	P700-900
CMB-P V-G1	○	X	X
CMB-P V-GA1	○	○	X
CMB-P V-HA1	X	X	○
CMB-P V-GB1	○	○	○
CMB-P V-HB1	○	○	○

★ Combination chart of BC Controller for WR2 series

	P200,250,300	P400,450,500,550,600
CMB-P V-G1	○	X
CMB-P V-GA1	○	○
CMB-P V-HA1	X	X
CMB-P V-GB1	○	○
CMB-P V-HB1	○	○

Notes:

- The equipment is for R410A refrigerant.
- Install this product in a location where noise (refrigerant noise) emitted by the unit will not disturb the neighbors. (For use in quiet environments with low background noise, position the BC CONTROLLER at least 5 m away from any indoor units.)
- Indoor units P100, P125, P140 can be connected to 1 branch. (In this case, cooling capacity decrease a little.)
- When using an outdoor unit – 28HP (P700) or more, use CMB-P1016V-HA1.

- For sub BC controller CMB-P-B-GB1 the connectable indoor unit capacities may sum to equal that of a P350 unit or less. However, if two sub controllers are used the TOTAL sum of connectable units connected to BOTH sub controllers must also not exceed that a P350 unit. For sub BC controller CMB-P-1016V-HB1 the connectable indoor unit capacities may sum to equal that of a P350 unit or less. However, if two sub controllers are used the TOTAL sum of connectable units connected to BOTH sub controllers must also not exceed that a P450 unit.

Air To Water series

PWFY-P100VM-E-BU **PWFY-EP100VM-E1-AU** **PWFY-P200VM-E1-AU**

Air To Water advanced system explained.

Air To Water (ATW) series offers the choice between two types of units; a Booster unit and a HEX (Heat Exchanger) unit. A Booster unit offers hot water to a maximum of 70°C and the HEX unit offers 40°C in heating and down to 10°C in cooling. Applying heat pump and heat recovery technology to provide hot water, the units are suitable for residences, office buildings, restaurants or hotels, providing an optimal environment while benefiting from reduced running costs and less impact on the environment.

An ATW system consists of an outdoor unit, a BC controller when connected with R2 series, ATW unit, indoor unit and a controller.

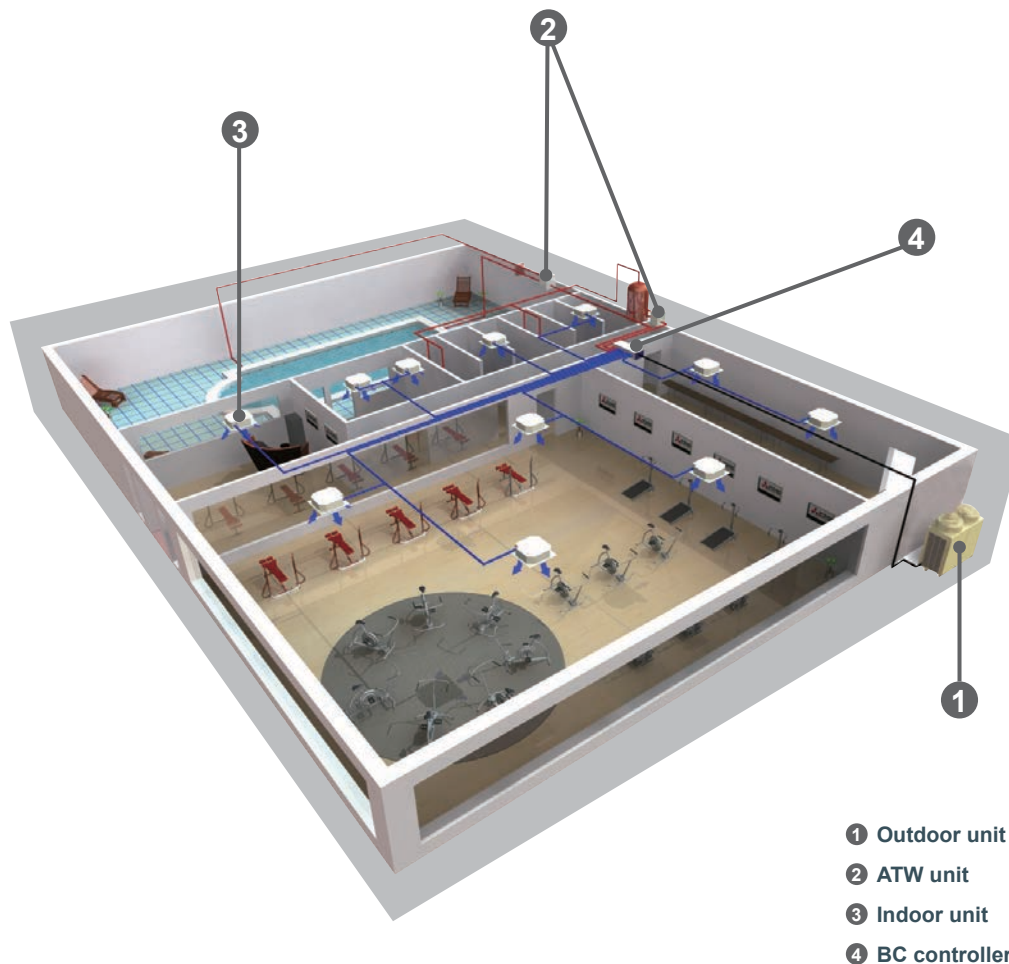

- ① Outdoor unit
- ② ATW unit
- ③ Indoor unit
- ④ BC controller

Line Up

① ATW UNIT

BOOSTER UNIT

Benefiting from the heat recovery operation of the CITY MULTI R2 system, the Booster unit converts energy from the air to higher temperatures suitable for supplying hot water, resulting in virtually no energy waste.



PWFY-P100VM-E-BU

Connectable to

CITY MULTI
R2/WR2 series
REPLACE MULTI
R2 series

Applications

best for sanitary
water, showers, etc.

Operation

up to 70°C

SYSTEM OUTLINE

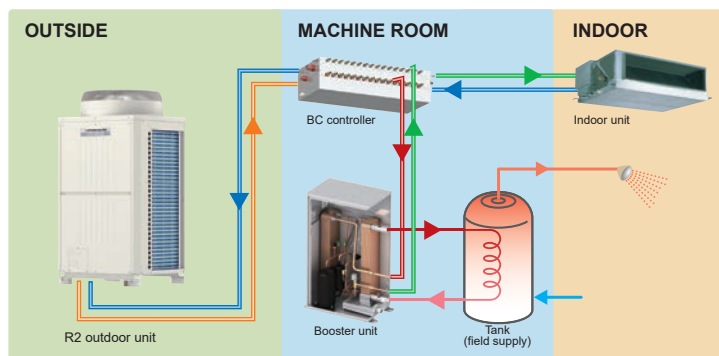

The Booster unit is connected to a BC controller with refrigerant pipes, and to the water tank with water pipes. The waste heat from cooling operation is utilised for heating operation to provide hot water.

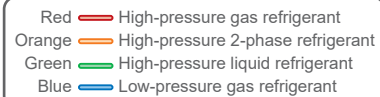

What makes Booster unit unique?

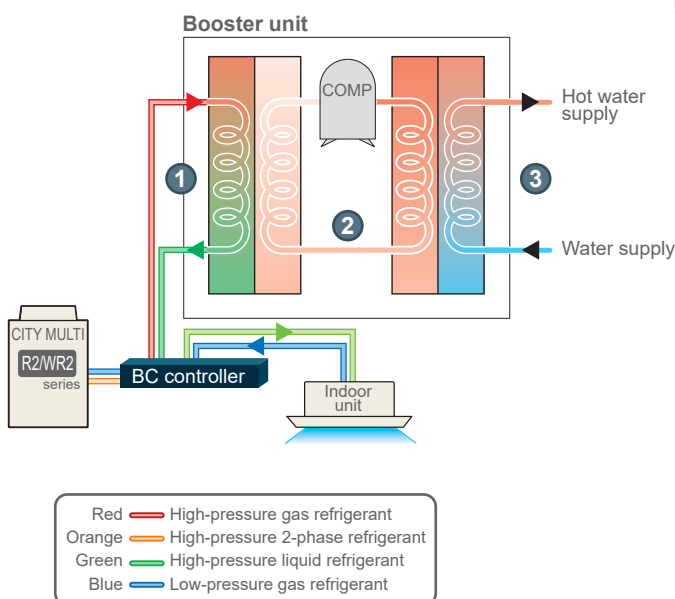

Refrigerant flow

- From the BC controller, high pressure R410A gas refrigerant is delivered to the Booster unit to exchange heat with the low pressure R134a liquid refrigerant circulating through ② and returns to the BC controller as a high pressure liquid refrigerant.
- Refrigerant R134a circulates inside the two plate heat exchangers inside the unit. Temperature rises as low-pressure R134a gas refrigerant is compressed by the compressor and becomes high-pressure gas refrigerant.

Water supply

- Water entering the Booster unit exchanges heat with high-pressure R134a gas refrigerant. The hot water circulates to heat the water inside the tank which will be used for showers, sanitary water, etc.

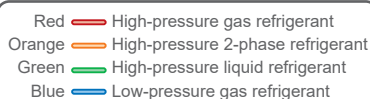

HEX UNIT

By utilising waste heat from the R2 outdoor unit for heating operation in the HEX unit, it is possible to supply hot water with high efficiency. Also, even when connected with a Y series system, it provides efficient operation compared to a conventional system.



PWFY-EP100VM-E1-AU
PWFY-P200VM-E1-AU

Connectable to

CITY MULTI
R2/WR2/
Y/WY/ZUBADAN series
S series
REPLACE MULTI
R2/Y series

Applications

best for floor heating, panel heater, fan-coil unit(AHU), etc.

Operation

hot water up to 45°C
cold water down to 8°C

SYSTEM OUTLINE HEX unit with R2 series

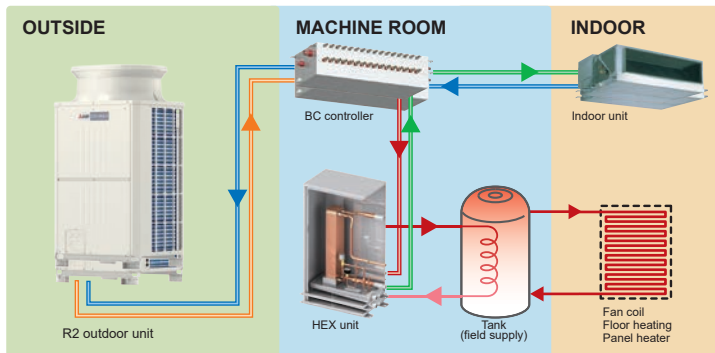

The HEX unit is connected to BC controller with refrigerant pipes, and to the water tank with water pipes. The HEX unit is not equipped with a compressor.

Red High-pressure gas refrigerant
Orange High-pressure 2-phase refrigerant
Green High-pressure liquid refrigerant
Blue Low-pressure gas refrigerant

*The image is a system example in case of heating mode.

*The necessity of the tank depends on the system configuration.

What makes HEX unit unique with R2/WR2 series?

Hot water supply

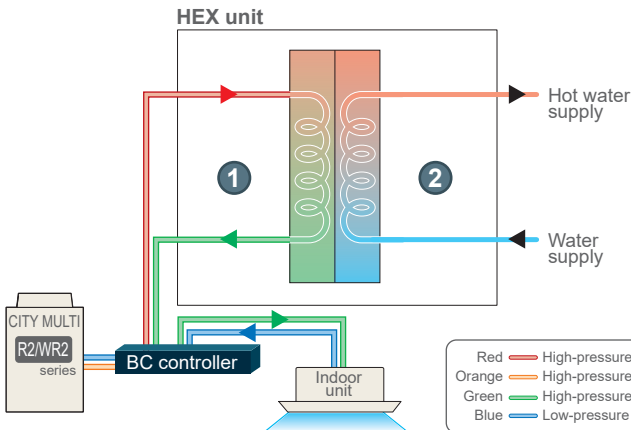

Refrigerant flow

- From the BC controller, high-pressure R410A gas refrigerant is delivered to the HEX unit and returns to the unit as high-pressure liquid refrigerant.

Water supply

- Water entering the HEX unit exchanges heat with the R410A refrigerant and water circulates to heat the water inside the tank.

Cold water supply

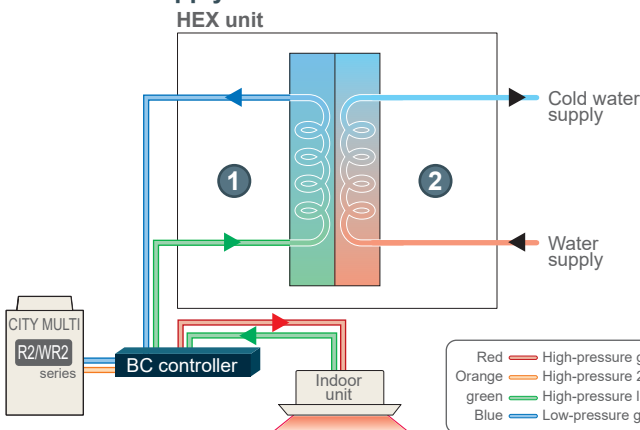

Refrigerant flow

- From the BC controller, high-pressure R410A liquid refrigerant is delivered to the HEX unit and returns to the unit as low-pressure gas refrigerant.

Water supply

- Water entering the HEX unit exchanges heat with the R410A refrigerant and water circulates to cool the water inside the tank.

Indoor Unit

SYSTEM OUTLINE HEX unit with Y series

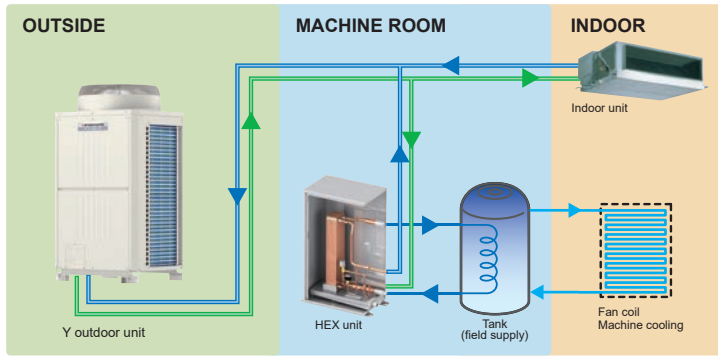

The HEX unit is connected to the Y series outdoor unit with refrigerant pipes, and to the water tank with water pipes. The HEX unit is not equipped with a compressor.

- Red — High-pressure gas refrigerant
- Orange — High-pressure 2-phase refrigerant
- Green — High-pressure liquid refrigerant
- Blue — Low-pressure gas refrigerant

What makes HEX unit unique with Y/WY series?

Hot water supply

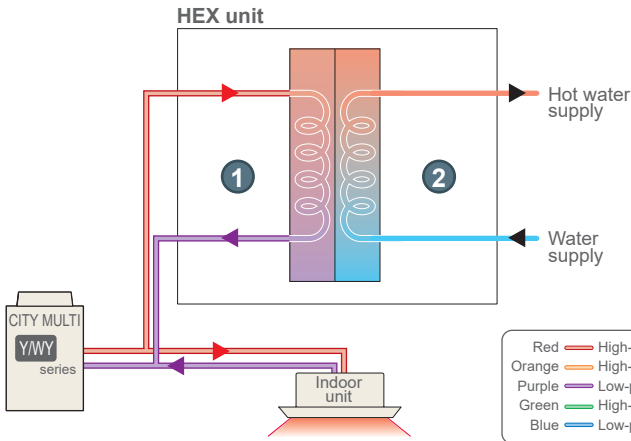

Refrigerant flow

- 1 From the outdoor unit, high-pressure R410A gas refrigerant is delivered to the HEX unit and returns to the unit as low-pressure 2-phase refrigerant.

Water supply

- 2 Water entering the HEX unit exchanges heat with the R410A refrigerant and water circulates to heat the water inside the tank.

- Red — High-pressure gas refrigerant
- Orange — High-pressure 2-phase refrigerant
- Purple — Low-pressure 2-phase refrigerant
- Green — High-pressure liquid refrigerant
- Blue — Low-pressure gas refrigerant

Cold water supply

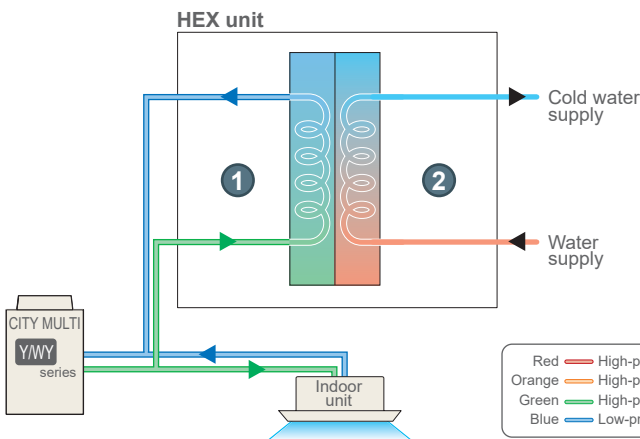

Refrigerant flow

- 1 From the outdoor unit, high-pressure R410A liquid refrigerant is delivered to the HEX unit and returns to the unit as low-pressure gas refrigerant.

Water supply

- 2 Water entering the HEX unit exchanges heat with the R410A refrigerant and water circulates to cool the water inside the tank.

- Red — High-pressure gas refrigerant
- Orange — High-pressure 2-phase refrigerant
- Green — High-pressure liquid refrigerant
- Blue — Low-pressure gas refrigerant

ATW UNIT

HEX Unit

PWFY-EP100VM-E1-AU



► Specifications

Model		PWFY-EP100VM-E1-AU	
Power source		1 - phase 220 - 230 - 240V 50 / 60Hz	
Heating capacity (Nominal)	*1 kW	12.5	
	*1 kcal / h	10,800	
	*1 BTU / h	42,700	
	Power input kW	0.015	
	Current input A	0.068 - 0.065 - 0.063	
Temp. range of heating	Outdoor temp. for outdoor unit	W.B.	-20 ~ 32°C (-4 ~ 90°F) R2 - series
		W.B.	-20 ~ 15.5°C (-4 ~ 60°F) Y - series
		W.B.	-25 ~ 15.5°C (-13 ~ 60°F) HP (ZUBADAN) - series
	Circulating Water temp. for heat source unit	-	10 ~ 45°C (50 ~ 113°F) WR2 - series
	Inlet Water temp. for PWFY	-	10 ~ 45°C (50 ~ 113°F) WY - series
Cooling capacity (Nominal)		*2 kW	11.2
		*2 kcal / h	9,600
		*2 BTU / h	38,200
		Power input kW	0.015
		Current input A	0.068 - 0.065 - 0.063
Temp. range of cooling	Outdoor temp. for outdoor unit	D.B.	-5 ~ 46°C (23 ~ 115°F) R2 - series
		D.B.	-5 ~ 46°C (23 ~ 115°F) Y - series
		D.B.	-5 ~ 43°C (23 ~ 110°F) HP (ZUBADAN) - series
	Circulating Water temp. for heat source unit	-	10 ~ 45°C (50 ~ 113°F) WR2 - series
	Inlet Water temp. for PWFY	-	10 ~ 45°C (50 ~ 113°F) WY - series
Connectable outdoor unit/ heat source unit		Total capacity	50~100% of outdoor/heat source unit capacity
		Model / Quantity	PUHY-P·Y(S)KB-A1(-BS), PUHY-EP·Y(S)LM-A(-BS), PUHY-HP·Y(S)HM-A(-BS), PQHY-P·Y(S)HM-A, PURY-(E)P·Y(S)LM-A(1)(-BS), PQRY-P·Y(S)HM-A
Sound pressure level (measured in anechoic room)		dB <A>	29
Diameter of refrigerant pipe	Liquid	mm (in.)	ø9.52 (ø3/8") Brazed
	Gas	mm (in.)	ø15.88 (ø5/8") Brazed
Diameter of water pipe	Inlet	mm (in.)	PT1 Screw (PT3/4 Screw without Expansion joint)
	Outlet	mm (in.)	PT1 Screw (PT3/4 Screw without Expansion joint)
Field drain pipe size		mm (in.)	ø32 (1-1/4")
External finish		NO	
External dimension H × W × D		mm	800 (785 without legs) × 450 × 300
		in.	31-1/2" (30-15/16" without legs) × 17-3/4" × 11-13/16"
Net weight		kg (lbs)	33 (73)
Circulating water	Operation Volume Range	m³ / h	1.8 ~ 4.30
Design pressure	R410A	MPa	4.15
	Water	MPa	1.00
Drawing	External	WKJ94T340	
	Wiring	WKE94C951	
Standard attachment	Document	Installation Manual, Instruction Book	
	Accessory	Strainer, Heat insulation material, Expansion joint, Flow switch × 1 set, Buffer material	
Optional parts		Solenoid valve kit: PAC-SV01PW-E	
Remark		Details on foundation work, duct work, insulation work, electrical wiring, power source switch, and other items shall be referred to the Installation Manual.	

Note: *1Nominal heating conditions (PWFY conditions are indicated in the parentheses.)
 <Y/HP(ZUBADAN)/R2-series> <WY/WR2-series>
 Outdoor Temp. : 7°CDB/6°CWB (45°FDB / 43°FWB) Circulating water Temp. : 20°C (68°F)
 Pipe length : 7.5 m (24-9/16 ft) Pipe length : 7.5 m (24-9/16 ft)
 Level difference : 0m (0ft) Level difference : 0m (0ft)
 (Inlet water Temp. 30°C, Water flow rate 4.30m³/h) (Inlet water Temp. for PWFY side 30°C, Water flow rate 4.30m³/h)

*2Nominal cooling conditions (PWFY conditions are indicated in the parentheses.)
 <Y/HP(ZUBADAN)/R2-series> <WY/WR2-series>
 Outdoor Temp. : 35°CDB (95°FDB) Circulating water Temp. : 30°C (86°F)
 Pipe length : 7.5 m (24-9/16 ft) Pipe length : 7.5 m (24-9/16 ft)
 Level difference : 0m (0ft) Level difference : 0m (0ft)
 (Inlet water Temp. 23°C, Water flow rate 3.86m³/h) (Inlet water Temp. for PWFY side 23°C, Water flow rate 3.86m³/h)

Unit converter	
kcal / h	=kW × 860
BTU / h	=kW × 3,412
cfm	=m³ / min × 35.31
lbs	=kg / 0.4536
* The specification data is subject to rounding variation.	

- * Due to continuing improvement, the above specifications may be subject to change without notice.
- * The unit is not designed for outside installations.
- * Please don't use the steel material for the water piping material.
- * Please always make water circulate or add the brine to the circulation water when the ambient temperature becomes 0°C or less.
- * Please always make water circulate or pull out the circulation water completely when not using it.
- * Please do not use ground water and well water.
- * Install the outdoor unit (R2-series) in an environment where the wet bulb Temp. will not exceed 32°C.
- * The water circuit must use the closed circuit.
- * Please do not use it as a drinking water.

ATW UNIT

HEX Unit

PWFY-P200VM-E1-AU



► Specifications

Model			PWFY-P200VM-E1-AU	
Power source			1-phase 220-230-240V 50 / 60Hz	
Heating capacity (Nominal)	*1	kW	25.0	
	*1	kcal/h	21,500	
	*1	BTU/h	85,300	
	Power input		kW	0.015
	Current input		A	0.068-0.065-0.063
Temp. range of heating	Outdoor unit/ Heat source unit condition	W.B.	-	
		W.B.	-20~-15.5°C (-4~60°F) Y - series	
		W.B.	-25~-15.5°C (-13~60°F) HP(ZUBADAN) - series	
		W.B.	-20~-32°C (-4~90°F) R2 - series	
		-	10~45°C (50~113°F) WY - series	
	-	10~45°C (50~113°F) WR2 - series		
	HEX unit inlet water temp.		-	10~40°C (50~104°F)
Cooling capacity (Nominal)	*2	kW	22.4	
	*2	kcal/h	19,300	
	*2	BTU/h	76,400	
	Power input		kW	0.015
	Current input		A	0.068-0.065-0.063
Temp. range of cooling	Outdoor unit/ Heat source unit condition	D.B.	-5~46°C (23~115°F) Y - series	
		D.B.	-5~43°C (23~110°F) HP(ZUBADAN) - series	
		D.B.	-5~46°C (23~115°F) R2 - series	
		-	10~45°C (50~113°F) WY - series	
		-	10~45°C (50~113°F) WR2 - series	
	HEX unit inlet water temp.		-	10~35°C (50~95°F)
Connectable outdoor unit/heat source unit	Total capacity		50~100% of outdoor unit/heat source unit capacity	
	Model / Quantity		Y (Standard, Hi-COP), Replace Y, HP(ZUBADAN) series, R2 (Standard, Hi-COP), Replace R2, WY series, WR2 series	
Sound pressure level (measured in anechoic room)		dB<A>	29	
Diameter of refrigerant pipe	Liquid	mm(in.)	ø9.52 (ø3/8") Braze	
	Gas	mm(in.)	ø19.05 (ø3/4") Braze	
Diameter of water pipe	Inlet	mm(in.)	PT 1 Screw	
	Outlet	mm(in.)	PT 1 Screw	
Field drain pipe size		mm(in.)	ø32 (1-1/4")	
External finish			NO	
External dimension H × W × D		mm	800 (785 without legs) × 450 × 300	
		in.	31-1/2" (30-15/16" without legs) × 17-3/4" × 11-13/16"	
Net weight		kg(lbs)	38 (84)	
Circulating water	Operation Volume Range		m³/h	1.8~4.30
	R410A	MPa	4.15	
Design pressure	Water		MPa	1.00
	External			KD94R274
Drawing	Wiring			WKE94C626
	Document		Installation Manual, Instruction Book	
Standard attachment	Strainer, Connector, Heat insulation material,			
	Accessory		2 × Connector sets, Expansion joint, Flow switch × 1 set, wire	
Optional parts			Solenoid valve kit: PAC-SV01PW-E	
Remark			Details on foundation work, duct work, insulation work, electrical wiring, power source switch, and other items shall be referred to the Installation Manual.	

Notes:

*1 Nominal heating conditions
<S/Y/HP(ZUBADAN)/R2-series>
Outdoor Temp. : 7°CDB/6°CWB (45°FDB / 43°FWB)
Pipe length : 7.5 m (24-9/16 ft)
Level difference : 0m (0ft)
Inlet water Temp 30°C
Water flow rate 2.15m³/h(P100), 4.30m³/h(P200)

<WY/WR2-series>
Circulating water Temp. : 20°C (68°F)
Pipe length : 7.5 m (24-9/16 ft)
Level difference : 0m (0ft)
Inlet water Temp 30°C
Water flow rate 2.15m³/h(P100), 4.30m³/h(P200)

*2 Nominal cooling conditions
<Y/HP(ZUBADAN)/R2-series>
Outdoor Temp. : 35°CDB (95°FDB)
Pipe length : 7.5 m (24-9/16 ft)
Level difference : 0m (0ft)
Inlet water Temp 23°C
Water flow rate 1.93m³/h(P100), 3.86m³/h(P200)

<WY/WR2-series>
Circulating water Temp. : 30°C (86°F)
Pipe length : 7.5 m (24-9/16 ft)
Level difference : 0m (0ft)
Inlet water Temp 23°C
Water flow rate 1.93m³/h(P100), 3.86m³/h(P200)

- * Due to continuing improvement, the above specifications may be subject to change without notice.
- * The unit is not designed for outside installations.
- * Please don't use the steel material for the water piping material.
- * Please always make water circulate or add the brine to the circulation water when the ambient temperature becomes 0°C (32°F) or less.
- * Please always make water circulate or pull out the circulation water completely when not using it.
- * Please do not use groundwater and well water.
- * Install the unit in an environment where the wet bulb Temp. will not exceed 32°C (90°F).
- * The water circuit must use the closed circuit.
- * Please do not use it as a drinking water.

ATW UNIT

Booster Unit

PWFY-P100VM-E-BU



► Specifications

Model		PWFY-P100VM-E-BU	
Power source		1-phase 220-230-240V 50 / 60Hz	
Heating capacity (Nominal)	*1 kW	12.5	
	*1 kcal/h	10,800	
	*1 BTU/h	42,700	
	Power input	kW	
Current input	A		
Temp. range of heating	Outdoor unit/Heat source unit condition	W.B.	-20~32°C (-4~90°F) R2-series
		-	10~45°C (50~113°F) WR2-series
	Booster unit inlet water temp.	-	10~70°C (50~158°F)
Connectable outdoor unit/heat source unit	Total capacity	50~100% of outdoor unit/heat source unit capacity	
	Model / Quantity	R2 (Standard, Hi-COP), Replace R2, WR2 series only	
Sound pressure level (measured in anechoic room)		dB<A>	
Diameter of refrigerant pipe	Liquid	mm(in.)	ø9.52 (ø3/8") Brazed
	Gas	mm(in.)	ø15.88 (ø5/8") Brazed
Diameter of water pipe	Inlet	mm(in.)	PT3/4 Screw
	Outlet	mm(in.)	PT3/4 Screw
Field drain pipe size	mm(in.)	ø32 (1-1/4")	
External finish		NO	
External dimension H × W × D	mm	800 (785 without legs) × 450 × 300	
	in.	31-1/2" (30-15/16" without legs) × 17-3/4" × 11-13/16"	
Net weight	kg(lbs)	60 (133)	
Compressor	Type	Inverter rotary hermetic compressor	
	Maker	MITSUBISHI ELECTRIC CORPORATION	
	Starting method	Inverter	
	Motor output	kW	1.0
	Lubricant	NEO22	
Circulating water	Operation volume Range	m³/h	0.6~2.15
Protection on internal circuit (R134a)	High pressure protection	High pressure sensor, High pressure switch at 3.60 MPa (601 psi)	
	Inverter circuit (COMP)	Over - heat protection, Over - current protection	
	Compressor	Discharge thermo protection, Over - current protection	
Refrigerant	Type × original charge	*2	R134a × 1.1kg (0.50lb)
	Control	LEV	
Design pressure	R410A	MPa	4.15
	R134a	MPa	3.60
	Water	MPa	1.00
Drawing	External	WKB94L762	
	Wiring	WKE94C229	
Standard attachment	Document	Installation Manual, Instruction Book	
	Accessory	Strainer, Heat insulation material, 2 × Connector sets	
Optional parts	NONE		
Remark	Details on foundation work, duct work, insulation work, electrical wiring, power source switch, and other items shall be referred to the Installation Manual.		

Notes:

*1 Nominal heating conditions

<R2-series>

Outdoor Temp. : 7°CDB/6°CWB (45°FDB / 43°FWB)
 Pipe length : 7.5 m (24-9/16 ft)
 Level difference : 0m (0ft)
 Inlet water Temp 65°C Water flow rate 2.15m³/h

<WR2-series>

Circulating water Temp. : 20°C (68°F)
 Pipe length : 7.5 m (24-9/16 ft)
 Level difference : 0m (0ft)
 Inlet water Temp 65°C Water flow rate 2.15m³/h

*2 Do not use refrigerant other than the type indicated in the manuals provided with the unit and on the nameplate.

- Doing so may cause the unit or pipes to burst, or result in explosion or fire during use, during repair, or at the time of disposal of the unit.
- It may also be in violation of applicable laws.
- MITSUBISHI ELECTRIC CORPORATION cannot be held responsible for malfunctions or accidents resulting from the use of the wrong type of refrigerant.

* Due to continuing improvement, the above specifications may be subject to change without notice.

* The unit is not designed for outside installations.

* Please don't use the steel material for the water piping material.

* Please always make water circulate or add the brine to the circulation water when the ambient temperature becomes 0°C (32°F) or less.

* Please always make water circulate or pull out the circulation water completely when not using it.

* Please do not use groundwater and well water.

* Install the unit in an environment where the wet bulb Temp. will not exceed 32°C (90°F).

* The water circuit must use the closed circuit.

* Please do not use it as a drinking water.

Indoor Unit

Controller Remote Controller PAR-W21MAA



► Specifications

○ : Each group × : Not available

Item	Description	Operations	Display
ON / OFF	Runs and stops the operation of a group of units	○	○
Operation mode switching	Switches between Hot Water / Heating / Heating ECO / Anti - freeze / Cooling * Available operation modes vary depending on the unit to be connected. * Switching limit setting can be made via a remote controller.	○	○
Water temperature setting	Temperature can be set within the ranges below. (in increments of 1°C or 1°F) Heating 30°C ~ 50°C Heating ECO 30°C ~ 45°C Hot Water 30°C ~ 70°C Anti-freeze 10°C ~ 45°C Cooling 10°C ~ 30°C * The settable range varies depending on the unit to be connected.	○	○
Preset temperature range limit	Preset temperature range setting can be limited via a remote controller.	○	○
Water temperature display	10°C ~ 90°C (in increments of 1°C or 1°F) * The settable range varies depending on the unit to be connected.	×	○
Permit / Prohibit local operation	Individually prohibits operations of each local remote control function : ON / OFF, Operation modes, water temperature setting, Circulating water replacement warning reset. * Upper level controller may not be connected depending on the unit to be connected.	×	○
Schedule operation	ON / OFF / Water temperature setting can be done up to 6 times one day in the week. (in increments of a minute)	○	○
Error display	When an error is currently occurring on a unit, the afflicted unit and the error code are displayed.	×	○
Self check (Error history)	Searches the latest error history by pressing the CHECK button twice.	○	○
Test run	Enables the Test run mode by pressing the TEST button twice. * Test run mode is not available depending on the unit to be connected.	○	○
Circulating water replacement warning	Displays the circulating water replacement warning via the unit message. Clears the display by pressing the CIR.WATER button twice. * Circulating water replacement warning is not available depending on the unit to be connected.	○	○
Operation locking function	Remote controller operation can be locked or unlocked. · All-switch locking · Locking except ON / OFF switch	○	○

Optional Parts Solenoid Valve Kit

Note:

If you intend to adopt PWFY-AU with below system configuration, you may need to use optional part (PAC-SV01PW-E).
Please contact your Mitsubishi Electric sales office for details.

Applicable System

System Configuration
Y, HP(ZUBADAN), Replace Y, or WY* + PWFY-AU + Indoor Unit

*Solenoid valve kit will be used only when operating the WY at the water temperature below 10°C.

PAC-SV01PW-E

Item	Description								
Power source	1-phase 220-230-240V 50 / 60Hz								
Diameter of refrigerant pipe	Applicable models								
	<table border="1"> <thead> <tr> <th></th> <th>PWFY-P100VM-E1-AU</th> <th>PWFY-P200VM-E1-AU</th> </tr> </thead> <tbody> <tr> <td>Liquid</td> <td>ø15.88</td> <td>ø19.05</td> </tr> <tr> <td>Gas</td> <td>ø9.52</td> <td>ø9.52</td> </tr> </tbody> </table>		PWFY-P100VM-E1-AU	PWFY-P200VM-E1-AU	Liquid	ø15.88	ø19.05	Gas	ø9.52
	PWFY-P100VM-E1-AU	PWFY-P200VM-E1-AU							
Liquid	ø15.88	ø19.05							
Gas	ø9.52	ø9.52							
External dimension H × W × D	mm								
	462 × 320 × 207								
Net weight	in.								
	18-1/4" × 12-5/8" × 8-3/16"								
Drawing	kg (lbs)								
	8.5 (19)								
Standard attachment	External								
	WKD94T532								
Standard attachment	Document								
	Installation Manual								
Standard attachment	Accessory								
	Specification label, Refrigerant conn.pipe								

RVX SERIES Energy Recovery Ventilators



The Ventilation System for Enhanced Air Quality - Lossnay

Combine with Lossnay Ventilation System for enhanced air quality.
Unified Control System allows for greater design freedom.

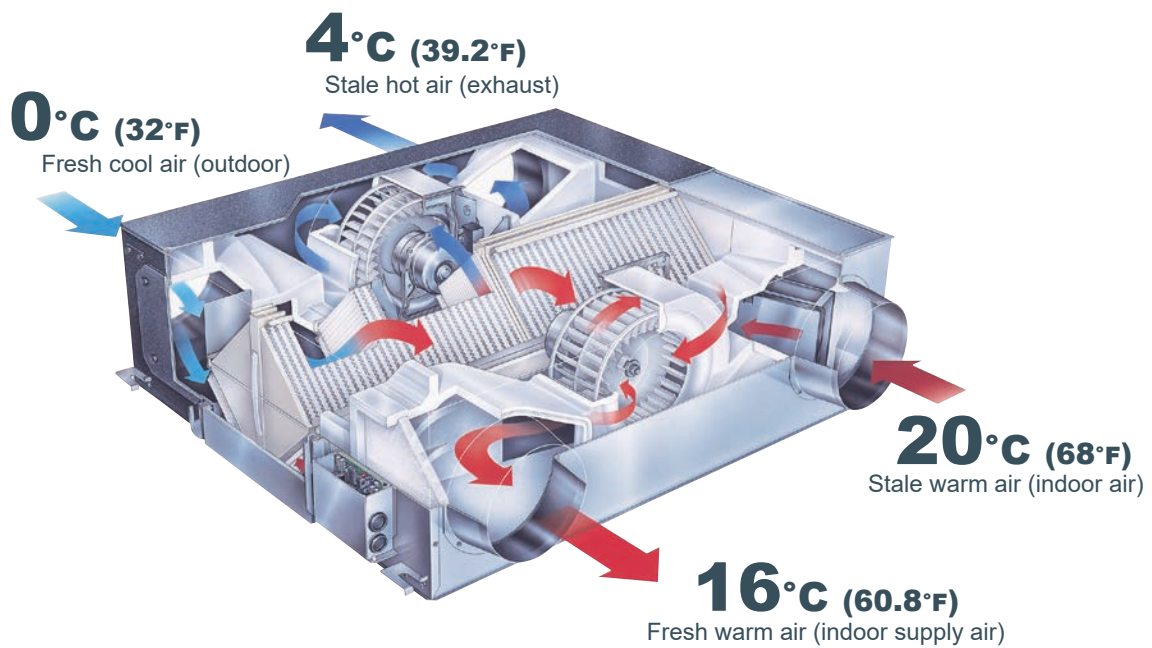

LGH-15RVX [150m³/h Single phase 220-240V 50Hz]
LGH-25RVX [250m³/h Single phase 220-240V 50Hz]
LGH-35RVX [350m³/h Single phase 220-240V 50Hz]
LGH-50RVX [500m³/h Single phase 220-240V 50Hz]
LGH-65RVX [650m³/h Single phase 220-240V 50Hz]

LGH-80RVX [800m³/h Single phase 220-240V 50Hz]
LGH-100RVX [1000m³/h Single phase 220-240V 50Hz]
LGH-150RVX [1500m³/h Single phase 220-240V 50Hz]
LGH-200RVX [2000m³/h Single phase 220-240V 50Hz]

Heat-exchange efficiency obtainable only with Lossnay.

The secret to the unmatched comfort provided by Lossnay core is the cross-flow, plate-fin structure of the heat-exchange unit. A diaphragm made of a specially processed paper fully separates inducted and exhausted air supplies, ensuring that only fresh air is introduced to the indoor environment.

The superior heat-transfer and moisture permeability of the special paper assures highly effective total heat-exchange (temperature and humidity) when inducted and exhausted air supplies cross in the Lossnay core.

LOSSNAY Technology

- **Two paths ventilation**
LOSSNAY simultaneously intakes Fresh Air and exhausts Dirty Air.
- **Total energy recovery**
LOSSNAY returns BOTH sensible heat and latent heat.

A. Two paths ventilation

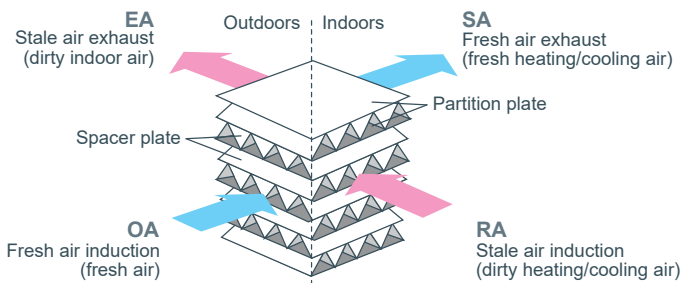

B. Total energy transfer

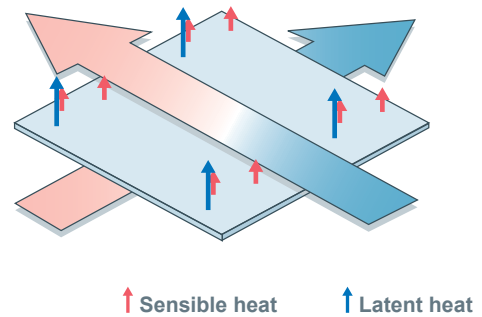

- **Hyper Eco Core**
Better energy conservation by improved total heat-exchange efficiency.

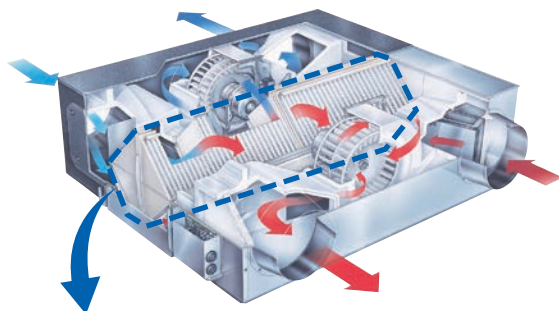

Introducing the new Hyper Eco Element

Mitsubishi Electric's newly developed Hyper Eco Element is on board, offering the industry's best total heat-exchange efficiency. Energy conservation performance has been improved not only by reducing the air conditioning load associated with ventilation, but also by facilitating humidity penetration.

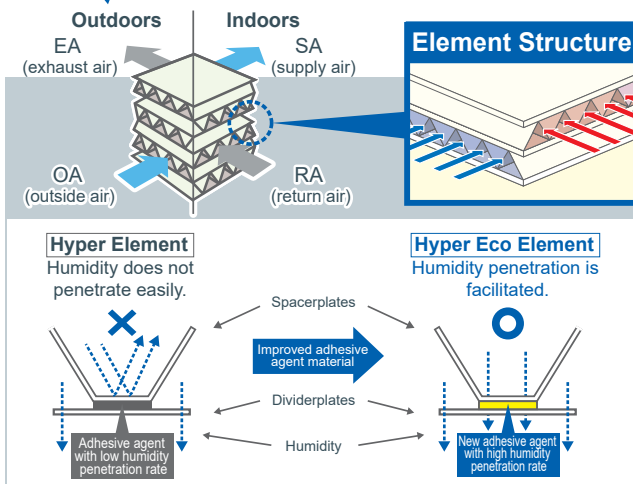

Why LOSSNAY is necessary

- A lack of ventilation makes people sick from stale indoor air including CO₂, dust and bacteria
- Opening windows eliminates the stale air, but wastes air-con energy
- **So we recommend LOSSNAY**
LOSSNAY simultaneously achieves ventilation and energy saving

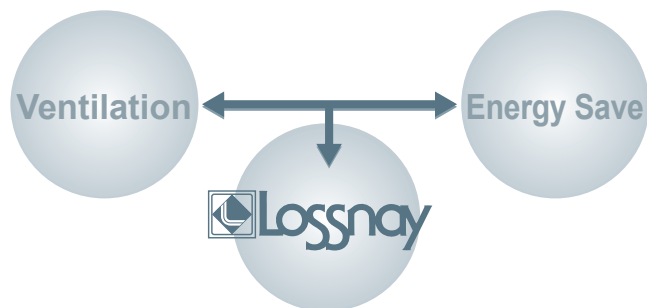

Wide range air volume

The new RVX Lossnay is equipped with four fan speeds. In addition, each speed has a range setting of 25, 50, 75 and 100%, allowing much finer air volume control.

When used in combination with the CO₂ sensor or timer function, the air volume can be controlled according to conditions that realise better performance and reduce power consumption.

■ RVX characteristic curves

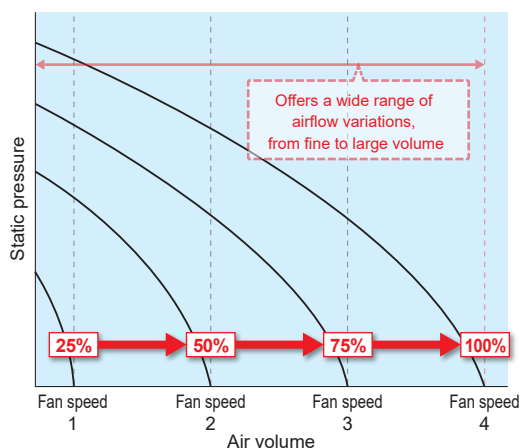

Weekly timer

The operation pattern for each day of the week, ON / OFF and air volume can be set using the weekly timer function (up to eight zones per day). Compared to previous models, much finer operation control contributes to enhanced energy saving operation. With a wider range of air volumes the Lossnay RVX units enable optimised ventilation not just at different times of the day, but for different days of the week as well, enabling further energy savings.

Previous model

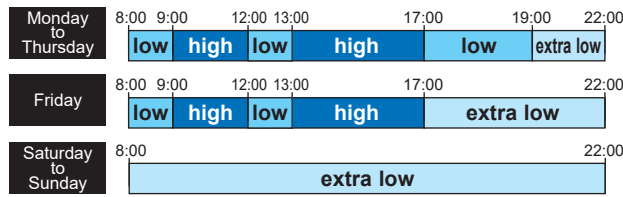

New model

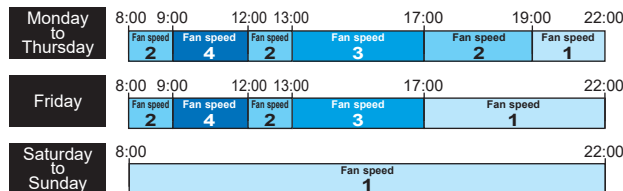

* Comparison of LGH-100R and LGH-100RVX

Total power consumption in a week

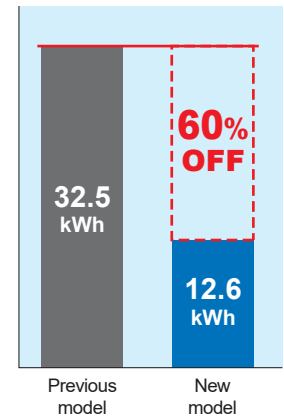

Improved external static pressure

External static pressure has been improved in the new RVX models. By increasing the external static pressure, highly flexible duct work becomes possible, thus renewal from existing equipment is easy.

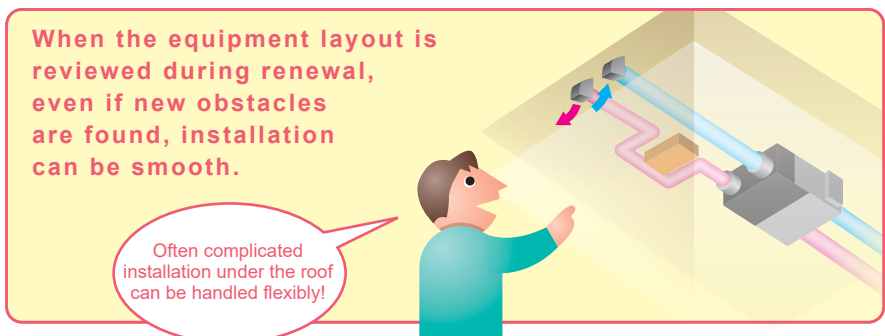

Fan speed adjustment function

The default fan speed value can be adjusted slightly. Using the PZ-61DR-E remote controller to reset the speed.

- 1) Considering the total hours of Lossnay operation (filter clogging), the fan power can be adjusted automatically after a given period of time.
- 2) After the unit is installed, if the air volume is slightly lower than the desired airflow, it is possible to make fine adjustments.

P-Q curve image

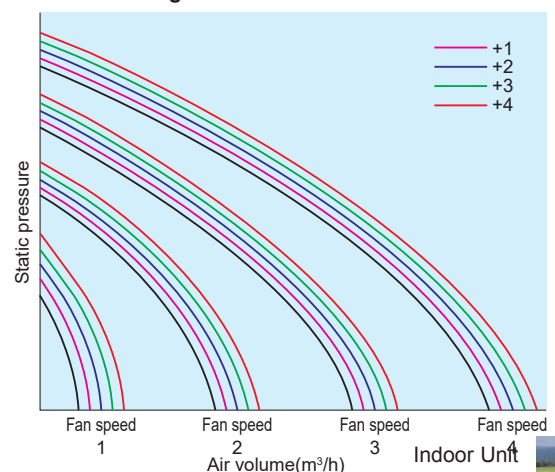

New function: "By-pass" Ventilation External Control Setting

In addition to the automatic damper open/close function, open/close control via external devices is now possible, delivering a "By-pass" ventilation system that is suitable to the installed environment.

Establish the wire connection by inserting the optional remote display adaptor (PAC-SA88HA-E) in the connector CN16 (Ventilation mode selector).

When SW1 is "ON", the ventilation mode of LOSSNAY is changed to the By-pass ventilation regardless of the setting on the remote controller.

•Automatic ventilation setting

The automatic damper mode automatically provides the correct ventilation for the conditions in the room. The following shows the effect "By-pass" ventilation will have under various conditions.

1. Reduces cooling load

If the air outside is cooler than the air inside the building during the cooling season (such as early morning or at night), "By-pass" ventilation will draw in the cooler outside air and reduce the cooling load on the system.

Control devices (example)

- Temperature sensor
- Humidity sensor
- Timers

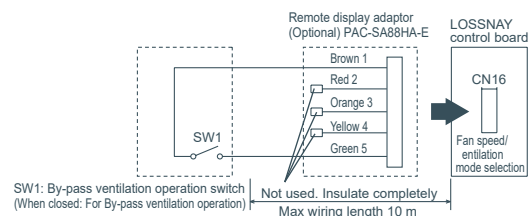
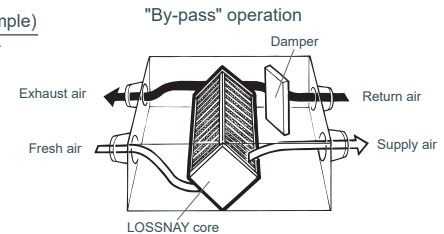

2. Night purge

"By-pass" ventilation can be used to release hot air from inside the building that accumulates in buildings during the hot summer season.

3. Office equipment room cooling

During the cold season, fresh air can be drawn in and used to cool rooms where the temperature has risen due to the use of office equipment.

* When the outdoor air temperature drops lower than 8°C it changes to the heat exchange ventilation. (Display of the remote controller does not change.)

* In the case of "By-pass" ventilation, the supply air temperature slightly rises more than the outside air temperature because of the heat effect around the ducts or the unit motors.

New Remote Controller PZ-61DR-E

A new remote controller for the RVX series is now available. In addition to boosting the energy conservation performance of the main unit, the remote controller features a variety of new functions which also allows for additional energy conservation.

The appearance of the remote controller conforms to the latest Mitsubishi Electric air conditioner interface design standards.

Functions that were set using Dip-Switch on the LOSSNAY main unit can be configured as needed using the new remote controller. This eliminates the need to crawl under the eaves to change operation settings.

Also, a newly adopted LCD backlight display provides much more information, making it easy to check maintenance indications, operation status display, and explanations required when configuring settings.

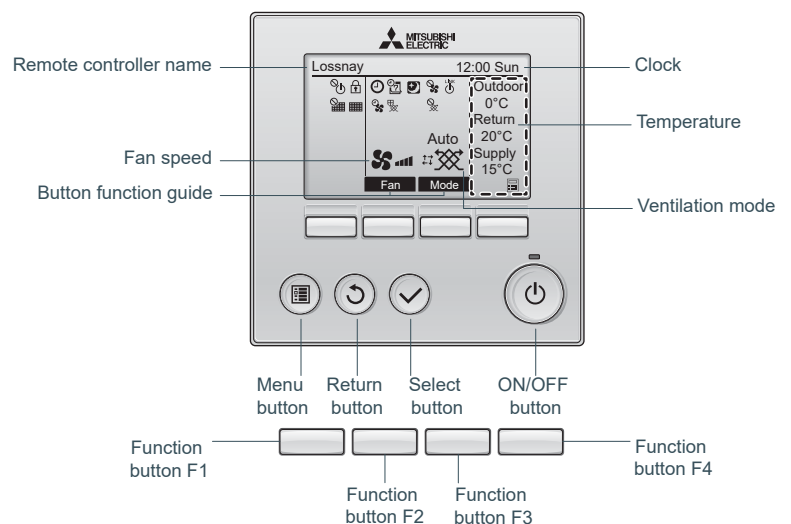

Specifications

Model line-up

NEW



LGH-15~100RVX-E

Model		LGH-15RVX-E								
Electrical power supply		220-240V/50Hz, 220V/60Hz								
Ventilation mode		Heat recovery mode				Bypass mode				
Fan speed		SP4	SP3	SP2	SP1	SP4	SP3	SP2	SP1	
Running current (A)		0.40	0.24	0.15	0.10	0.41	0.25	0.15	0.10	
Input power (W)		49	28	14	7	52	28	14	8	
Air volume		(m ³ /h)	150	113	75	38	150	113	75	38
		(L/s)	42	31	21	10	42	31	21	10
External static pressure (Pa)		95	54	24	6	95	54	24	6	
Temperature exchange efficiency (%)		80.0	81.0	83.0	84.0	—	—	—	—	
Enthalpy exchange efficiency (%)		Heating	73.0	75.5	78.0	79.0	—	—	—	—
		Cooling	71.0	74.5	78.0	79.0	—	—	—	—
Noise (dB) (Measured at 1.5m under the center of unit in an anechoic chamber)		28.0	24.0	19.0	17.0	29.0	24.0	19.0	18.0	
Weight (kg)		20								

*The Air outlets noise (45 angle, 1.5meters in front of the unit) is about 13dB greater than the indicated value. (at Fan speed 4)

*The running current, the input power, the efficiency and the noise are based on the rating air volume, and 230V/50Hz.

*For the specification at the other frequency contact your dealer.

Model		LGH-25RVX-E								
Electrical power supply		220-240V/50Hz, 220V/60Hz								
Ventilation mode		Heat recovery mode				Bypass mode				
Fan speed		SP4	SP3	SP2	SP1	SP4	SP3	SP2	SP1	
Running current (A)		0.48	0.28	0.16	0.10	0.48	0.29	0.16	0.11	
Input power (W)		62	33	16	7.5	63	35	17	9	
Air volume		(m ³ /h)	250	188	125	63	250	188	125	63
		(L/s)	69	52	35	17	69	52	35	17
External static pressure (Pa)		85	48	21	5	85	48	21	5	
Temperature exchange efficiency (%)		79.0	80.0	82.0	86.0	—	—	—	—	
Enthalpy exchange efficiency (%)		Heating	69.5	72.0	76.0	83.0	—	—	—	—
		Cooling	68.0	70.0	74.5	83.0	—	—	—	—
Noise (dB) (Measured at 1.5m under the center of unit in an anechoic chamber)		27.0	22.0	20.0	17.0	27.5	23.0	20.0	17.0	
Weight (kg)		23								

*The Air outlets noise (45 angle, 1.5meters in front of the unit) is about 15dB greater than the indicated value. (at Fan speed 4)

*The running current, the input power, the efficiency and the noise are based on the rating air volume, and 230V/50Hz.

*For the specification at the other frequency contact your dealer.

Model		LGH-35RVX-E								
Electrical power supply		220-240V/50Hz, 220V/60Hz								
Ventilation mode		Heat recovery mode				Bypass mode				
Fan speed		SP4	SP3	SP2	SP1	SP4	SP3	SP2	SP1	
Running current (A)		0.98	0.54	0.26	0.12	0.98	0.56	0.28	0.13	
Input power (W)		140	70	31	11	145	72	35	13	
Air volume		(m ³ /h)	350	263	175	88	350	263	175	88
		(L/s)	97	73	49	24	97	73	49	24
External static pressure (Pa)		160	90	40	10	160	90	40	10	
Temperature exchange efficiency (%)		80.0	82.5	86.0	88.5	—	—	—	—	
Enthalpy exchange efficiency (%)		Heating	71.5	74.0	78.5	83.5	—	—	—	—
		Cooling	71.0	73.0	78.0	82.0	—	—	—	—
Noise (dB) (Measured at 1.5m under the center of unit in an anechoic chamber)		32.0	28.0	20.0	17.0	32.5	28.0	20.0	18.0	
Weight (kg)		30								

*The Air outlets noise (45 angle, 1.5meters in front of the unit) is about 12dB greater than the indicated value. (at Fan speed 4)

*The running current, the input power, the efficiency and the noise are based on the rating air volume, and 230V/50Hz.

*For the specification at the other frequency contact your dealer.

NEW



LGH-15~100RVX-E

Model		LGH-50RVX-E								
Electrical power supply		220-240V/50Hz, 220V/60Hz								
Ventilation mode		Heat recovery mode				Bypass mode				
Fan speed		SP4	SP3	SP2	SP1	SP4	SP3	SP2	SP1	
Running current (A)		1.15	0.59	0.26	0.13	1.15	0.59	0.27	0.13	
Input power (W)		165	78	32	12	173	81	35	14	
Air volume		(m ³ /h)	500	375	250	125	500	375	250	125
		(L/s)	139	104	69	35	139	104	69	35
External static pressure (Pa)		120	68	30	8	120	68	30	8	
Temperature exchange efficiency (%)		78.0	81.0	83.5	87.0	—	—	—	—	
Enthalpy exchange efficiency (%)		Heating	69.0	71.0	75.0	82.5	—	—	—	—
		Cooling	66.5	68.0	72.5	82.0	—	—	—	—
Noise (dB) (Measured at 1.5m under the center of unit in an anechoic chamber)		34.0	28.0	19.0	18.0	35.0	29.0	20.0	18.0	
Weight (kg)		33								

*The Air outlets noise (45 angle, 1.5meters in front of the unit) is about 18dB greater than the indicated value. (at Fan speed 4)

*The running current, the input power, the efficiency and the noise are based on the rating air volume, and 230V/50Hz.

*For the specification at the other frequency contact your dealer.

Model		LGH-65RVX-E								
Electrical power supply		220-240V/50Hz, 220V/60Hz								
Ventilation mode		Heat recovery mode				Bypass mode				
Fan speed		SP4	SP3	SP2	SP1	SP4	SP3	SP2	SP1	
Running current (A)		1.65	0.90	0.39	0.15	1.72	0.86	0.38	0.16	
Input power (W)		252	131	49	15	262	131	47	17	
Air volume		(m ³ /h)	650	488	325	163	650	488	325	163
		(L/s)	181	135	90	45	181	135	90	45
External static pressure (Pa)		120	68	30	8	120	68	30	8	
Temperature exchange efficiency (%)		77.0	81.0	84.0	86.0	—	—	—	—	
Enthalpy exchange efficiency (%)		Heating	68.5	71.0	76.0	82.0	—	—	—	—
		Cooling	66.0	69.5	74.0	81.0	—	—	—	—
Noise (dB) (Measured at 1.5m under the center of unit in an anechoic chamber)		34.5	29.0	22.0	18.0	35.5	29.0	22.0	18.0	
Weight (kg)		38								

*The Air outlets noise (45 angle, 1.5meters in front of the unit) is about 16dB greater than the indicated value. (at Fan speed 4)

*The running current, the input power, the efficiency and the noise are based on the rating air volume, and 230V/50Hz.

*For the specification at the other frequency contact your dealer.

Model		LGH-80RVX-E								
Electrical power supply		220-240V/50Hz, 220V/60Hz								
Ventilation mode		Heat recovery mode				Bypass mode				
Fan speed		SP4	SP3	SP2	SP1	SP4	SP3	SP2	SP1	
Running current (A)		1.82	0.83	0.36	0.15	1.97	0.86	0.40	0.15	
Input power (W)		335	151	60	18	340	151	64	20	
Air volume		(m ³ /h)	800	600	400	200	800	600	400	200
		(L/s)	222	167	111	56	222	167	111	56
External static pressure (Pa)		150	85	38	10	150	85	38	10	
Temperature exchange efficiency (%)		79.0	82.5	84.0	85.0	—	—	—	—	
Enthalpy exchange efficiency (%)		Heating	71.0	73.5	78.0	81.0	—	—	—	—
		Cooling	70.0	72.5	78.0	81.0	—	—	—	—
Noise (dB) (Measured at 1.5m under the center of unit in an anechoic chamber)		34.5	30.0	23.0	18.0	36.0	30.0	23.0	18.0	
Weight (kg)		48								

*The Air outlets noise (45 angle, 1.5meters in front of the unit) is about 24dB greater than the indicated value. (at Fan speed 4)

*The running current, the input power, the efficiency and the noise are based on the rating air volume, and 230V/50Hz.

*For the specification at the other frequency contact your dealer.

*Use this unit with static pressure 240Pa or less at Fan speed 4. Otherwise the noise level might be larger.

Indoor Unit

NEW



LGH-15~100RVX-E



LGH-150/200RVX-E

Model		LGH-100RVX-E								
Electrical power supply		220-240V/50Hz, 220V/60Hz								
Ventilation mode		Heat recovery mode				Bypass mode				
Fan speed		SP4	SP3	SP2	SP1	SP4	SP3	SP2	SP1	
Running current (A)		2.50	1.20	0.50	0.17	2.50	1.20	0.51	0.19	
Input power (W)		420	200	75	21	420	200	75	23	
Air volume		(m ³ /h)	1000	750	500	250	1000	750	500	250
		(L/s)	278	208	139	69	278	208	139	69
External static pressure (Pa)		170	96	43	11	170	96	43	11	
Temperature exchange efficiency (%)		80.0	83.0	86.5	89.5	—	—	—	—	
Enthalpy exchange efficiency (%)		Heating	72.5	74.0	78.0	87.0	—	—	—	—
		Cooling	71.0	73.0	77.0	85.5	—	—	—	—
Noise (dB) (Measured at 1.5m under the center of unit in an anechoic chamber)		37.0	31.0	23.0	18.0	38.0	32.0	24.0	18.0	
Weight (kg)		54								

*The Air outlets noise (45 angle, 1.5meters in front of the unit) is about 21dB greater than the indicated value. (at Fan speed 4)

*The running current, the input power, the efficiency and the noise are based on the rating air volume, and 230V/50Hz.

*For the specification at the other frequency contact your dealer.

*Use this unit between static pressure 60Pa and 240Pa at Fan speed 4. Otherwise the motor protection may work and reduce its output or the noise level might be larger.

Model		LGH-150RVX-E								
Electrical power supply		220-240V/50Hz, 220V/60Hz								
Ventilation mode		Heat recovery mode				Bypass mode				
Fan speed		SP4	SP3	SP2	SP1	SP4	SP3	SP2	SP1	
Running current (A)		3.71	1.75	0.70	0.29	3.85	1.78	0.78	0.30	
Input power (W)		670	311	123	38	698	311	124	44	
Air volume		(m ³ /h)	1500	1125	750	375	1500	1125	750	375
		(L/s)	417	313	208	104	417	313	208	104
External static pressure (Pa)		175	98	44	11	175	98	44	11	
Temperature exchange efficiency (%)		80.0	82.5	84.0	85.0	—	—	—	—	
Enthalpy exchange efficiency (%)		Heating	72.0	73.5	78.0	81.0	—	—	—	—
		Cooling	70.5	72.5	78.0	81.0	—	—	—	—
Noise (dB) (Measured at 1.5m under the center of unit in an anechoic chamber)		39.0	32.0	24.0	18.0	40.5	33.0	26.0	18.0	
Weight (kg)		98								

*The Air outlets noise (45 angle, 1.5meters in front of the unit) is about 22dB greater than the indicated value. (at Fan speed 4)

*The running current, the input power, the efficiency and the noise are based on the rating air volume, and 230V/50Hz.

*For the specification at the other frequency contact your dealer.

*Use this unit with static pressure 250Pa or less at Fan speed 4. Otherwise the noise level might be larger.

Model		LGH-200RVX-E								
Electrical power supply		220-240V/50Hz, 220V/60Hz								
Ventilation mode		Heat recovery mode				Bypass mode				
Fan speed		SP4	SP3	SP2	SP1	SP4	SP3	SP2	SP1	
Running current (A)		4.88	2.20	0.88	0.33	4.54	2.06	0.87	0.35	
Input power (W)		850	400	153	42	853	372	150	49	
Air volume		(m ³ /h)	2000	1500	1000	500	2000	1500	1000	500
		(L/s)	556	417	278	139	556	417	278	139
External static pressure (Pa)		150	84	38	10	150	84	38	10	
Temperature exchange efficiency (%)		80.0	83.0	86.5	89.5	—	—	—	—	
Enthalpy exchange efficiency (%)		Heating	72.5	74.0	78.0	87.0	—	—	—	—
		Cooling	71.0	73.0	77.0	85.5	—	—	—	—
Noise (dB) (Measured at 1.5m under the center of unit in an anechoic chamber)		40.0	36.0	28.0	18.0	41.0	36.0	27.0	19.0	
Weight (kg)		110								

*The Air outlets noise (45 angle, 1.5meters in front of the unit) is about 21dB greater than the indicated value. (at Fan speed 4)

*The running current, the input power, the efficiency and the noise are based on the rating air volume, and 230V/50Hz.

*For the specification at the other frequency contact your dealer.

*Use this unit between static pressure 50Pa and 220Pa at Fan speed 4. Otherwise the motor protection may work and reduce its output or the noise level might be larger.

The new Remote Controller PZ-61DR-E enables simple control setting

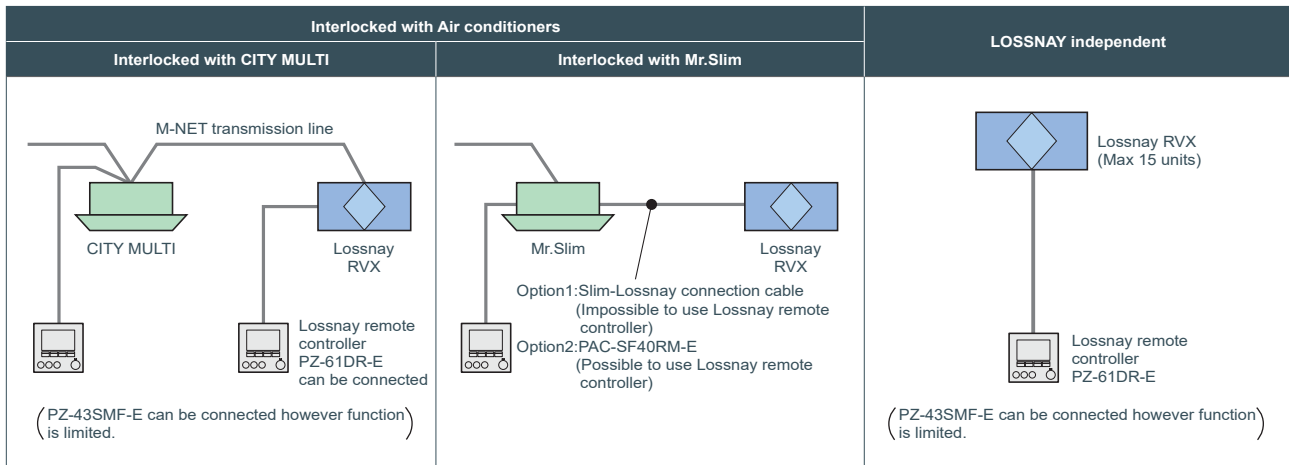

Centralised Controller System

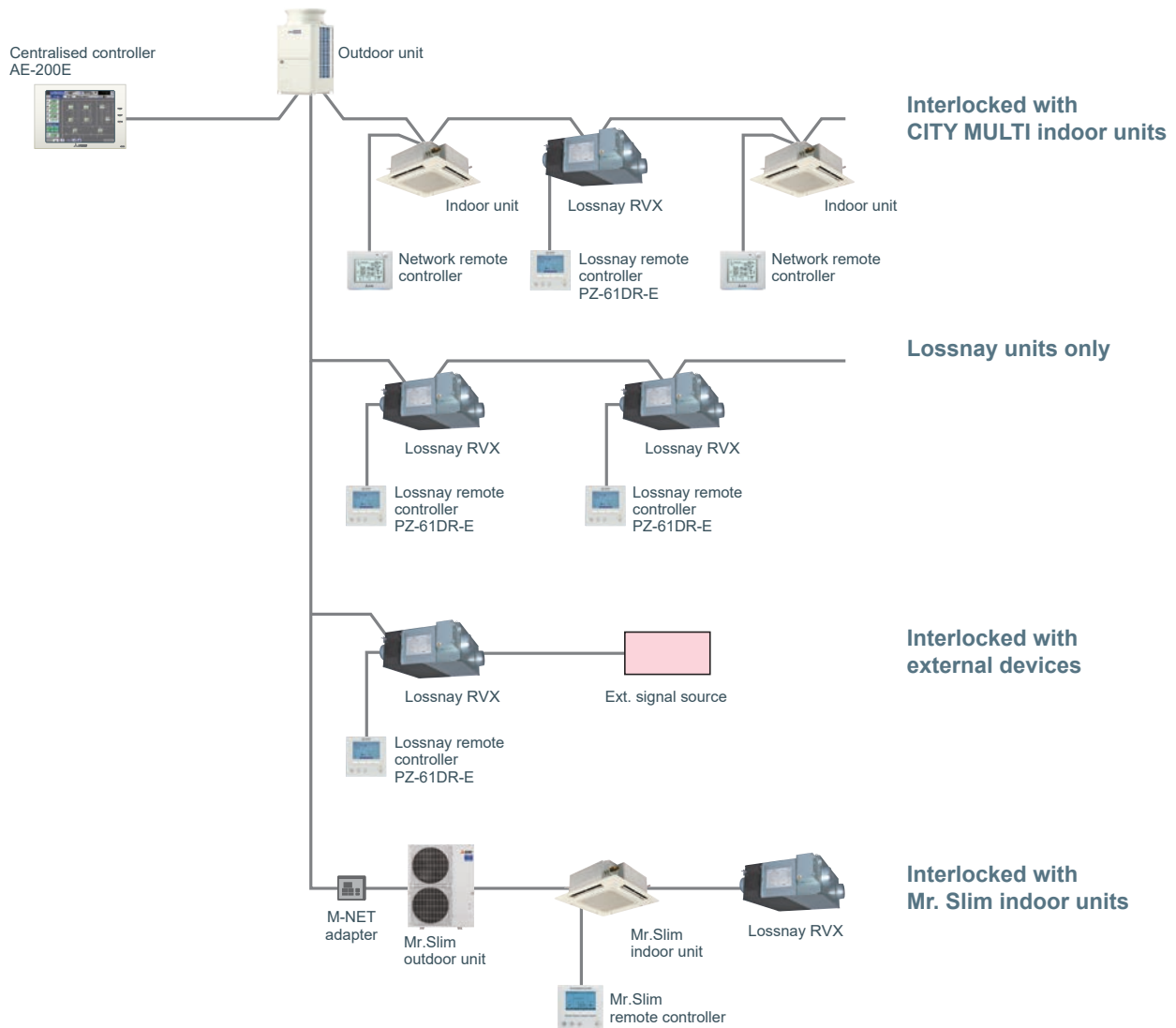

Indoor Unit

NEW



VL-100EU5-E Wall switch type

Energy Recovery Ventilator

Enjoy the benefits of Lossnay Heat Recovery Ventilation in a wall mounted unit.

Energy Saving

Reduced heat loss contributes to lower air conditioning costs.

Fresh Air

Simultaneous air supply/exhaust function ensures efficient ventilation.

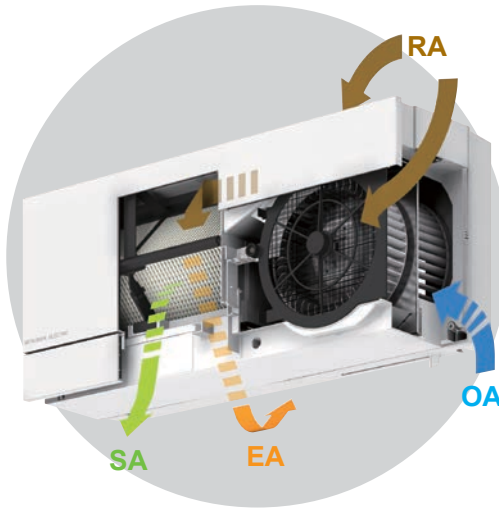

Quiet Operation

Equipped with sound insulation for even quieter operation.

Simple Installation

Easy installation through boring of 2 installation holes.

Stylish Design

Designed to match any interior decor.

Total-Heat-Exchange Concept

Operation in Winter

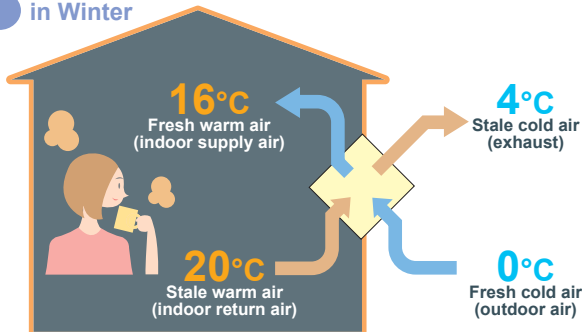

•Heat-exchange Temp. equation

$$\text{Indoor supply-air temperature}(\text{°C}) = \left\{ \text{Indoor temperature}(\text{°C}) - \text{Outdoor temperature}(\text{°C}) \right\} \times \text{Temp exchange efficiency}(\%) + \text{Outdoor temperature}(\text{°C})$$

Calculation example : 16°C = (20°C - 0°C) x 80% + 0°C (Low fan speed)

Operation in Summer

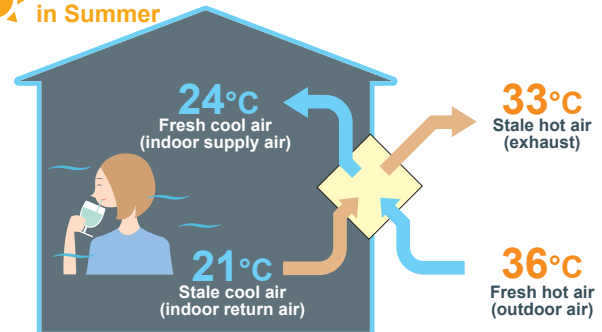

•Heat-exchange Temp. equation

$$\text{Indoor supply-air temperature}(\text{°C}) = \left\{ \text{Outdoor temperature}(\text{°C}) - \text{Indoor temperature}(\text{°C}) \right\} \times \text{Temp exchange efficiency}(\%) + \text{Indoor temperature}(\text{°C})$$

Calculation example : 24°C = 36°C - (36°C - 21°C) x 80% (Low fan speed)

Specification

- Simple installation through boring of 2 installation holes.
- Low-noise (Less than 30dB at low fan speed).
- 1-motor 2-fan system. •Air-volume:low/high fan speeds.
- Air-supply/exhaust pipes and a plastic weather cover are included.
- Equipped with an outdoor-air shutter.
- Wall-switch (VL-100EU5-E)

Supply voltage (V)	Power line frequency (Hz)	Fan speed	Air volume (m³/h)	Power consumption (W)	Temp.exchange efficiency (%)	Noise (dB)	Weight (kg)
220	50	HI	100	30	73	36.5	7.5
		LO	55	13	80	24	
230	50	HI	105	31	73	37	
		LO	60	15	80	25	
240	50	HI	106	34	72	38	
		LO	61	17	79	27	
220	60	HI	103	34	73	38	
		LO	57	17	80	25	

Optional Parts

High-performance filter P-100HF5-E

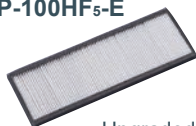

- Upgraded high-performance filter.

Replacement filter P-100F5-E



- Standard grade replacement filter.

Extension pipe P-100P-E



- Total length when connected to the pipe extension coupling is 300mm.

Extension pipe coupling P-100PJ-E



- Screw-in method

Indoor Unit

Air Handling Unit Controller

PAC-AH-M-J

The Air Handling Unit Controller is an interface to allow connection to third party manufacturers equipment.

Mitsubishi Electric City Multi outdoor units are used with this interface box, creating an ideal solution when a unique air handling unit is required. The Air Handling Unit Controllers are supplied with LEV expansion device(s).

- Discharge or return air temperature control
- Temperature set point by control 0-10VDC
- Auto mode available for ease of application
- Error input
- IP2x rated (only for internal use)



PAC-AH-M-J - AHU Controller

MODEL REFERENCE		PAC-AH125M-J	PAC-AH125M-J	PAC-AH140M-J	PAC-AH250M-J	PAC-AH250M-J	PAC-AH500M-J	PAC-AH500M-J
AIR HANDLING UNIT SIZE		P100	P125	P140	P200	P250	P400*2	P500*2
ALLOWED HEAT EXCHANGER CAPACITY (KW) - HEATING (MIN/MAX)		10.0 - 12.5	12.5 - 16.0	16.0 - 18.0	18.0 - 25.0	25.0 - 31.5	40.0 - 50.0	50.0 - 63.0
ALLOWED HEAT EXCHANGER CAPACITY (KW) - COOLING (MIN/MAX)		9.0 - 11.2	11.2 - 14.0	14.0 - 16.0	16.0 - 22.4	22.4 - 28.0	36.0 - 45.0	45.0 - 56.0
ALLOWED HEAT EXCHANGER VOLUME (CM ³)		1500 - 2850	1900 - 3550	2150 - 4050	3000 - 5700	3750 - 7100	6000 - 11400	7500 - 14200
REFERENCE AIR FLOW RATE (M3/H)*3		2000	2500	3000	4000	5000	8000	10000
STANDARD EVAPORATOR PATH NUMBER*1		4 - 5	4 - 5	5 - 6	6 - 10	8 - 10	16 - 20	16 - 20
DIMENSIONS (MM)	WIDTH	328	328	328	328	328	328	328
	() = INC MOUNTINGS							
	DEPTH	104 (122)	104 (122)	104 (122)	104 (122)	104 (122)	104 (122)	104 (122)
	HEIGHT	378 (420)	378 (420)	378 (420)	378 (420)	378 (420)	378 (420)	378 (420)
WEIGHT (KG)		5	5	5	5	5	5	5
PIPE SIZE (MM)	GAS	15.88	15.88	15.88	19.05	22.22	28.58	28.58
	LIQUID	9.52	9.52	9.52	9.52	9.52	12.7	15.88

Note: One air handling unit controller is required per air handling unit. Saturated refrigerant temperature at exit of evaporator = 8.5°C, SH = 5K, liquid temperature = 25°C, air = 27°CDB/19°CWB.

*1 When the diameter of the heat exchanger tube is ø9.52.

*2 P400 and P500 are not compatible with PURY and PQRY.

*3 If using in combination with standard indoor units, then these figures do not apply.

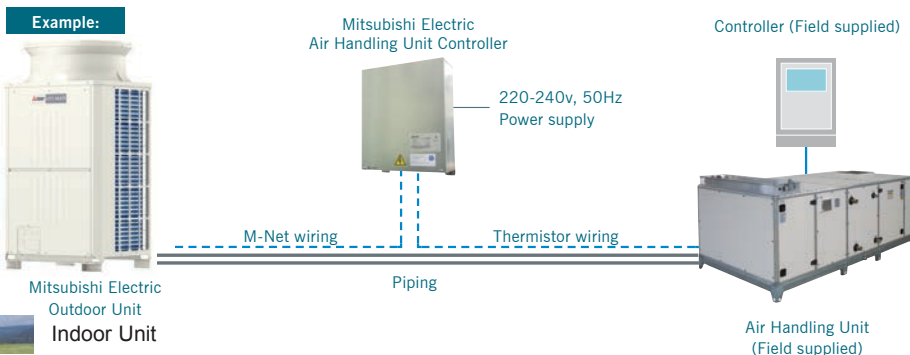

APPLICABLE OUTDOOR UNITS	
PUHY-P Y(S)KB-A	PURY-P Y(S)LM-A
PUHY-EP Y(S)LM-A	PURY-EP Y(S)LM-A
PUHY-HP Y(S)HM-A	PQRY-P Y(S)LM-A
PQHY-P Y(S)LM-A	

OA Processing Units

RD4 Series

A Total Air Conditioning Package for Remarkable Power

Lossnay Ventilation and Air Conditioning

1. When the load is light ⇒ Main air conditioning
2. When the load is heavy ⇒ Supplemental air conditioning

The OA (Outdoor-Air) Processing Unit creates an optimum environment while providing substantial energy savings. The OA Processing Unit comprises forced air ventilation, heat recovery, heating and cooling, and air purification. This total air conditioning system keeps indoor air fresh and comfortable all year round and keeps it free of contaminants, preventing ailments such as sick building syndrome. Inside the OA Processing Unit is the Lossnay Core, a heat-exchange unit that transfers heat efficiently, cutting ventilation load by as much as 70%. A remarkable product found nowhere else, this special combination of functionality and performance contained within a single unit ensures users ample comfort, good health, and energy savings.

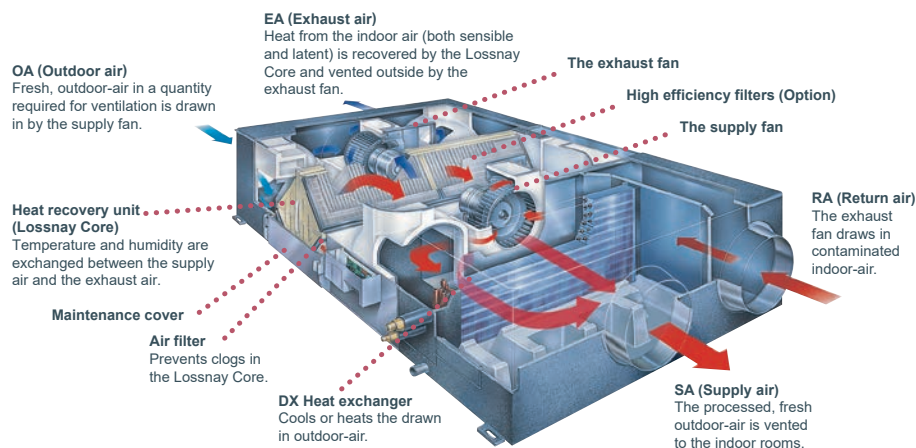

The Air Conditioning Function

Two Units in One

Along with Lossnay ventilation, the OA Processing Unit is really two units in one, functioning as the main air conditioner when the load is light and adding supplemental air conditioning when the load is heavy. Also, with ventilation and air conditioning integrated, space is saved and installation expense kept to a minimum. What's more, the air temperature in any room can be perfectly adjusted to the desired

temperature of the occupants via the OA Processing Unit, which can be used as the indoor unit of the CITY MULTI air conditioning system. The heat recovery function maximises efficiency and saves energy, benefiting the environment and helping companies cut costs. It also reduces the refrigerant load and lowers the amount of horsepower required by the outdoor unit.

Temperature simulation (Example : GUF-50RD₄)

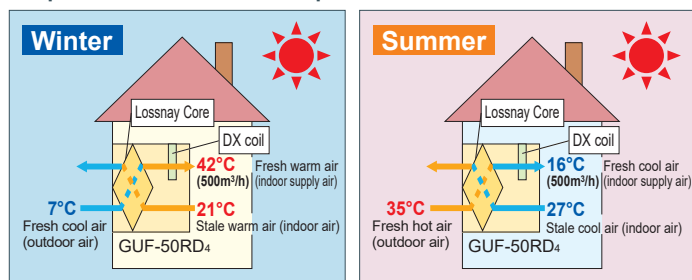

Specification



Model			GUF-50RD4		GUF-100RD4		
Power source			1-phase 220-240V 50Hz				
Cooling capacity	*1	kW	5.57	<1.94>	11.44	<4.12>	
Figure in < > is the recovery capacity by LOSSNAY core.	*1	kcal / h	4,800	<1,650>	9,800	<3,500>	
	*1	BTU / h	19,000	<6,600>	39,000	<14,000>	
	*3	Power input	235-265		480-505		
	*3	Current input	1.15		2.20		
Heating capacity	*2	kW	6.21	<2.04>	12.56	<4.26>	
Figure in < > is the recovery capacity by LOSSNAY core.	*2	kcal / h	5,340	<1,750>	10,800	<3,650>	
	*2	BTU / h	21,200	<7,000>	42,850	<14,450>	
	*3	Power input	235-265		480-505		
	*3	Current input	1.15		2.20		
Capacity equivalent to indoor unit			P32		P63		
Humidifying capacity			kg / h		—		
			lbs / h		—		
	Humidifier		Permeable film humidifier		—		
External finish			Galvanized, with grey insulation sheet				
External dimension H x W x D			mm		317 x 1,016 x 1,288		
			in.		12-1/2 x 40 x 50-3/4		
Net weight			kg (lbs)		48 (106)		
Heat exchanger	LOSSNAY core		Partition, Cross-flow structure, Special preserved paper-plate.				
	Refrigerant coil		Cross fin (Aluminum fin and copper tube)				
FAN	Type x Quantity		SA: Centrifugal fan (Sirocco fan) x 1				
			EA: Centrifugal fan (Sirocco fan) x 1				
	External static press.	*4	Pa	140		140	
			mmH ₂ O	14.3		14.3	
	Motor type			Totally enclosed capacitor permanent split-phase induction motor, 4 poles, 2units			
	Motor output			kW		—	
	Driving mechanism			Direct-driven by motor			
Airflow rate (High value)		m ³ / h	500		1,000		
		L / s	139		278		
		cfm	294		589		
Sound pressure level (Low-High) (measured in anechoic room)			*3		dB <A>		
					33.5-34.5		
Insulation material			Polyester sheet				
Air filter	Supplying air		Non-woven fabrics filter (Gravitational method 82%) & Optional part: High efficiency filter (Colorimetric method 65%)				
	Exhausting air		Non-woven fabrics filter (Gravitational method 82%)				
Protection device			Fuse				
Refrigerant control device			LEV				
Connectable outdoor unit			R410A CITY MULTI				
Diameter of refrigerant pipe	Liquid	mm (in.)	ø6.35 (ø1/4) Flare		ø9.52 (ø3/8) Flare		
	Gas	mm (in.)	ø12.7 (ø1/2) Flare		ø15.88 (ø5/8) Flare		
Field drain pipe size			mm (in.)		Socket (I.D. 32mm (1-1/4))+O.D. 32mm (1-1/4)		

Notes:

- *1 Nominal cooling conditions
Indoor : 27°CDB/19°CWB (81°FDB/66°FWB)
Outdoor : 35°CDB (95°FDB)
- *2 Nominal heating conditions
Indoor : 20°CDB (68°FDB)
Outdoor : 7°CDB/6°CWB (45°FDB/43°FWB)
- *3 The values are measured at the rated external static pressure.
- *4 The figure in < > indicates the value when external static pressure is changed.



Remote Controller

— **Individual Remote Controller**

— **Centralised Remote Controller**



The Importance of Control

The need for control is paramount in order to optimise the performance of any air conditioning system and minimise its running costs. Mitsubishi Electric offers a wide range of control options designed to meet such needs.

Operating an air conditioning system without the right control can prove costly. It's therefore important to ensure that every system is correctly specified to the degree of control it requires. Mitsubishi Electric have a wide range of controls available 'off-the-shelf' and individual control systems can be specifically designed to match.

Good controls will benefit any application, large or small. Air conditioning products need to react to a variety of factors: different room sizes, usage and staff levels; changes in the climate; electronic equipment and lighting...the list goes on. So whatever the application, optimum control of air conditioning systems is essential and will result in a constant, comfortable environment, which in turn is both energy and cost efficient.

A Degree of Difference

When an air conditioning system is not properly controlled, it will not run as efficiently as it should. For every degree that the system deviates from the required temperature, energy costs can rise by up to 5%. Specify one of the many control options from Mitsubishi Electric to ensure air conditioning works as intended, whilst giving the optimum amount of control.

The Simpler, The Better

With the array of comprehensive control systems available from Mitsubishi Electric, it becomes simple to design and install air conditioning systems. From a simple hand-held controller to an AE-200E system - you are in control.



Remote Controller

System Controller

MITSUBISHI ELECTRIC's Air conditioner Network System (MELANS) leads air conditioner management in a PC browser and Network era.

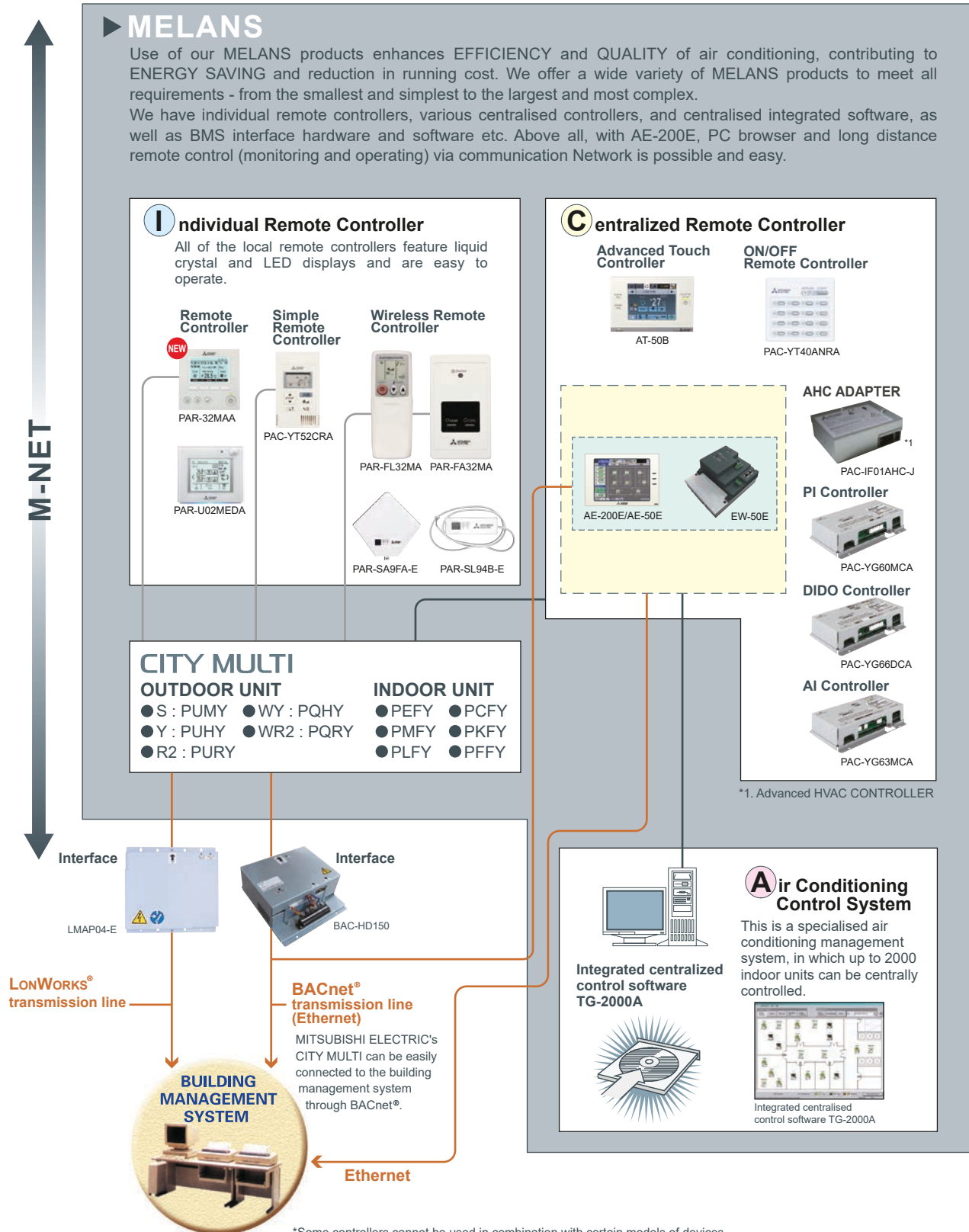

*Some controllers cannot be used in combination with certain models of devices.

Integrated Communications Control with Mitsubishi Electric's Unique Transmission Network (M-NET)

Model	Local remote controller *9				System controller *9																																																																																																																																																																																																																																																																																																																																																																																																																																																																																																																																																																																																																																																																																																																								
	PAR-32MAA	PAR-U02MEDA	PAC-YT52CRA	PAR-FL32MA	PAC-YT40ANRA	AT-50B	AE-200E	AE-200E + AE-50E / EW-50E	EW-50E	AG-150A	AG-150A + PAC-YG50ECA	TG-2000A *15																																																																																																																																																																																																																																																																																																																																																																																																																																																																																																																																																																																																																																																																																																																	
Controllable Groups / Indoors (Group / Indoor) *8	1 / 16	1 / 16	1 / 16	1 / 16	16 / 50	50 / 50	50 / 50	200 / 200	50 / 50	50 / 50	150 / 150	2000 / 2000																																																																																																																																																																																																																																																																																																																																																																																																																																																																																																																																																																																																																																																																																																																	
■Operating													ON / OFF	○	○	○	○	◎	◎	◎	◎	◎	◎	◎	◎	Mode (cool / heat / dry / fan)	○	○	○	○	N	◎	◎	◎	◎	N	◎	◎	Temperature-set	○	○	○	○	N	◎	◎	◎	◎	N	◎	◎	Dual set point *10	○	○	○	N	○ ^{*11}	◎	◎	◎	◎	N	N	N	Local Permit / Prohibit	N	N	N	N	N	◎	◎	◎	◎	N	◎	◎	Fan speed	○	○	○	○	N	◎	◎	◎	◎	N	◎	◎	Air-flow direction	○	○	○	○	N	◎	◎	◎	◎	N	◎	◎	■Status monitoring													ON / OFF	○	○	○	○	◎	◎	◎	◎	◎	▲	◎	◎	Mode (cool / heat / dry / fan)	○	○	○	○	N	◎	◎	◎	◎	N	◎	◎	Temperature-set	○	○	○	○	N	◎	◎	◎	◎	N	◎	◎	Local Permit / Prohibit	○	○	○	○	○	◎	◎	◎	◎	N	◎	◎	Fan speed	○	○	○	○	N	◎	◎	◎	◎	N	◎	◎	Air-flow direction	○	○	○	○	N	◎	◎	◎	◎	N	◎	◎	Indoor temperature	○	○	○	N	N	◎	◎	◎	◎	N	◎	◎	Filter sign	○	○	N	N	N	◎	◎	◎	◎	N	◎	◎	Error flashing	○	○	○	○	○	◎	◎	◎	◎	▲	◎	◎	Error code	○	○	○	N	○	◎	◎	◎	◎	N	◎	◎	Operation hour	N	N	N	N	N	N	N	N	N	N	N	N	■Scheduling													One-day	○	○	N	N	N	○	◎	◎	◎	N	◎	◎	Times of ON / OFF per day	1	1	N	1	N	16	24	24	24	24	24	24	Weekly	○	○	N	N	N	○	◎	◎	◎	N	◎	◎	Times of ON / OFF per week	8 x 7	8 x 7	N	N	N	16 x 7	24 x 7	24 x 7	24 x 7	24 x 7	24 x 7	24 x 7	Annual	N	N	N	N	N	N	◎	◎	◎	N	◎	◎	Optimized start-up	N	N	N	N	N	N	○	○	○	N	○	○	Auto-off timer	○	○	N	N	N	N	N	N	N	N	N	N	Min. timer setting unit (minute)	5	5	N	10	N	5	1	1	1	1	N	1	■Recording													Error record	○	N	N	N	N	○	○	○	○	N	○	○	Daily / monthly report	N	N	N	N	N	N	N	N	N	N	N	N	Electricity charge	N	N	N	N	N	N	N	●	N	N	N	N	Energy management data	N	N	N	N	N	N	●	●	●	●	N	●	■Other													Temp-set limitation by Local R/C	○	○	○	N	N	N	N	N	N	N	N	N	Temp-set limitation by System controller *4	○ ^{*6}	○	○ ^{*6}	N	N	○ ^{*6}	N	○ ^{*2*6}	N	○ ^{*2*6}	N	○ ^{*2*6}	Operation-lock	○	○	○	N	◎	N	N	N	N	N	N	N	Night setback	○	○	N	N	N	◎	○ ^{*2}	○ ^{*2}	○ ^{*2}	N	○ ^{*2}	○ ^{*2}	Sliding temperature control	N	N	N	N	N	N	○ ^{*2}	○ ^{*2}	○ ^{*2}	N	○ ^{*2}	○ ^{*2}	BACnet® connection	N	N	N	N	N	N	●	●	●	●	N	N	■Management (Group / Interlocked)													Ventilation interlock	N / ○	N / ○	N / ○	N	○	○	○ / ○ ^{*2}	○ / ○ ^{*2}	N	○ / ○ ^{*2}	○ / ○ ^{*2}	○ / ○ ^{*2}	Group setting	○ ^{*1}	○	○ ^{*1}	N	○	○	○ ^{*2}	○ ^{*2}	N	○ ^{*2}	○ ^{*2}	○ ^{*2}	Block setting	N	N	N	N	N	N	○ ^{*2}	○ ^{*2}	N	○ ^{*2}	○ ^{*2}	○ ^{*2}	Revision of electricity charge	N	N	N	N	N	N	N	N	N	N	N	□ ●	■Operating on LOSSNAY interlocked (Group / Interlocked)													ON / OFF	N / ○	N / ○	N / ○	N / ○ ^{*7}	◎ / ○ ^{*3}	◎ / ◎	◎ / ◎	◎ / ◎	◎ / ◎	▲ / ▲	◎ / ◎	◎ / ◎	Fan speed	N / ○	N / ○	N	N	N	◎ / ◎	◎ / ◎	◎ / ◎	◎ / ◎	N / N	◎ / ◎	◎ / ◎	Ventilation mode	N / N	N	N	N	N	◎ / N	◎ / N	◎ / N	◎ / N	N / N	◎ / N	◎ / N	■Status monitoring on LOSSNAY interlocked (Group / Interlocked)													ON / OFF	N / ○	N / ○	N / ○	N	N	○ / ○	◎ / ◎	◎ / ◎	◎ / ◎	▲ / ▲	◎ / ◎	◎ / ◎	Fan speed	N / ○	N / ○	N	N	N	○ / ○	◎ / ◎	◎ / ◎	◎ / ◎	N / N	◎ / ◎	◎ / ◎	Ventilation mode	N	N	N	N	N	○ / N	◎ / N	◎ / N	◎ / N	N / N	◎ / N	◎ / N
ON / OFF	○	○	○	○	◎	◎	◎	◎	◎	◎	◎	◎																																																																																																																																																																																																																																																																																																																																																																																																																																																																																																																																																																																																																																																																																																																	
Mode (cool / heat / dry / fan)	○	○	○	○	N	◎	◎	◎	◎	N	◎	◎																																																																																																																																																																																																																																																																																																																																																																																																																																																																																																																																																																																																																																																																																																																	
Temperature-set	○	○	○	○	N	◎	◎	◎	◎	N	◎	◎																																																																																																																																																																																																																																																																																																																																																																																																																																																																																																																																																																																																																																																																																																																	
Dual set point *10	○	○	○	N	○ ^{*11}	◎	◎	◎	◎	N	N	N																																																																																																																																																																																																																																																																																																																																																																																																																																																																																																																																																																																																																																																																																																																	
Local Permit / Prohibit	N	N	N	N	N	◎	◎	◎	◎	N	◎	◎																																																																																																																																																																																																																																																																																																																																																																																																																																																																																																																																																																																																																																																																																																																	
Fan speed	○	○	○	○	N	◎	◎	◎	◎	N	◎	◎																																																																																																																																																																																																																																																																																																																																																																																																																																																																																																																																																																																																																																																																																																																	
Air-flow direction	○	○	○	○	N	◎	◎	◎	◎	N	◎	◎																																																																																																																																																																																																																																																																																																																																																																																																																																																																																																																																																																																																																																																																																																																	
■Status monitoring													ON / OFF	○	○	○	○	◎	◎	◎	◎	◎	▲	◎	◎	Mode (cool / heat / dry / fan)	○	○	○	○	N	◎	◎	◎	◎	N	◎	◎	Temperature-set	○	○	○	○	N	◎	◎	◎	◎	N	◎	◎	Local Permit / Prohibit	○	○	○	○	○	◎	◎	◎	◎	N	◎	◎	Fan speed	○	○	○	○	N	◎	◎	◎	◎	N	◎	◎	Air-flow direction	○	○	○	○	N	◎	◎	◎	◎	N	◎	◎	Indoor temperature	○	○	○	N	N	◎	◎	◎	◎	N	◎	◎	Filter sign	○	○	N	N	N	◎	◎	◎	◎	N	◎	◎	Error flashing	○	○	○	○	○	◎	◎	◎	◎	▲	◎	◎	Error code	○	○	○	N	○	◎	◎	◎	◎	N	◎	◎	Operation hour	N	N	N	N	N	N	N	N	N	N	N	N	■Scheduling													One-day	○	○	N	N	N	○	◎	◎	◎	N	◎	◎	Times of ON / OFF per day	1	1	N	1	N	16	24	24	24	24	24	24	Weekly	○	○	N	N	N	○	◎	◎	◎	N	◎	◎	Times of ON / OFF per week	8 x 7	8 x 7	N	N	N	16 x 7	24 x 7	24 x 7	24 x 7	24 x 7	24 x 7	24 x 7	Annual	N	N	N	N	N	N	◎	◎	◎	N	◎	◎	Optimized start-up	N	N	N	N	N	N	○	○	○	N	○	○	Auto-off timer	○	○	N	N	N	N	N	N	N	N	N	N	Min. timer setting unit (minute)	5	5	N	10	N	5	1	1	1	1	N	1	■Recording													Error record	○	N	N	N	N	○	○	○	○	N	○	○	Daily / monthly report	N	N	N	N	N	N	N	N	N	N	N	N	Electricity charge	N	N	N	N	N	N	N	●	N	N	N	N	Energy management data	N	N	N	N	N	N	●	●	●	●	N	●	■Other													Temp-set limitation by Local R/C	○	○	○	N	N	N	N	N	N	N	N	N	Temp-set limitation by System controller *4	○ ^{*6}	○	○ ^{*6}	N	N	○ ^{*6}	N	○ ^{*2*6}	N	○ ^{*2*6}	N	○ ^{*2*6}	Operation-lock	○	○	○	N	◎	N	N	N	N	N	N	N	Night setback	○	○	N	N	N	◎	○ ^{*2}	○ ^{*2}	○ ^{*2}	N	○ ^{*2}	○ ^{*2}	Sliding temperature control	N	N	N	N	N	N	○ ^{*2}	○ ^{*2}	○ ^{*2}	N	○ ^{*2}	○ ^{*2}	BACnet® connection	N	N	N	N	N	N	●	●	●	●	N	N	■Management (Group / Interlocked)													Ventilation interlock	N / ○	N / ○	N / ○	N	○	○	○ / ○ ^{*2}	○ / ○ ^{*2}	N	○ / ○ ^{*2}	○ / ○ ^{*2}	○ / ○ ^{*2}	Group setting	○ ^{*1}	○	○ ^{*1}	N	○	○	○ ^{*2}	○ ^{*2}	N	○ ^{*2}	○ ^{*2}	○ ^{*2}	Block setting	N	N	N	N	N	N	○ ^{*2}	○ ^{*2}	N	○ ^{*2}	○ ^{*2}	○ ^{*2}	Revision of electricity charge	N	N	N	N	N	N	N	N	N	N	N	□ ●	■Operating on LOSSNAY interlocked (Group / Interlocked)													ON / OFF	N / ○	N / ○	N / ○	N / ○ ^{*7}	◎ / ○ ^{*3}	◎ / ◎	◎ / ◎	◎ / ◎	◎ / ◎	▲ / ▲	◎ / ◎	◎ / ◎	Fan speed	N / ○	N / ○	N	N	N	◎ / ◎	◎ / ◎	◎ / ◎	◎ / ◎	N / N	◎ / ◎	◎ / ◎	Ventilation mode	N / N	N	N	N	N	◎ / N	◎ / N	◎ / N	◎ / N	N / N	◎ / N	◎ / N	■Status monitoring on LOSSNAY interlocked (Group / Interlocked)													ON / OFF	N / ○	N / ○	N / ○	N	N	○ / ○	◎ / ◎	◎ / ◎	◎ / ◎	▲ / ▲	◎ / ◎	◎ / ◎	Fan speed	N / ○	N / ○	N	N	N	○ / ○	◎ / ◎	◎ / ◎	◎ / ◎	N / N	◎ / ◎	◎ / ◎	Ventilation mode	N	N	N	N	N	○ / N	◎ / N	◎ / N	◎ / N	N / N	◎ / N	◎ / N																																																																																																								
ON / OFF	○	○	○	○	◎	◎	◎	◎	◎	▲	◎	◎																																																																																																																																																																																																																																																																																																																																																																																																																																																																																																																																																																																																																																																																																																																	
Mode (cool / heat / dry / fan)	○	○	○	○	N	◎	◎	◎	◎	N	◎	◎																																																																																																																																																																																																																																																																																																																																																																																																																																																																																																																																																																																																																																																																																																																	
Temperature-set	○	○	○	○	N	◎	◎	◎	◎	N	◎	◎																																																																																																																																																																																																																																																																																																																																																																																																																																																																																																																																																																																																																																																																																																																	
Local Permit / Prohibit	○	○	○	○	○	◎	◎	◎	◎	N	◎	◎																																																																																																																																																																																																																																																																																																																																																																																																																																																																																																																																																																																																																																																																																																																	
Fan speed	○	○	○	○	N	◎	◎	◎	◎	N	◎	◎																																																																																																																																																																																																																																																																																																																																																																																																																																																																																																																																																																																																																																																																																																																	
Air-flow direction	○	○	○	○	N	◎	◎	◎	◎	N	◎	◎																																																																																																																																																																																																																																																																																																																																																																																																																																																																																																																																																																																																																																																																																																																	
Indoor temperature	○	○	○	N	N	◎	◎	◎	◎	N	◎	◎																																																																																																																																																																																																																																																																																																																																																																																																																																																																																																																																																																																																																																																																																																																	
Filter sign	○	○	N	N	N	◎	◎	◎	◎	N	◎	◎																																																																																																																																																																																																																																																																																																																																																																																																																																																																																																																																																																																																																																																																																																																	
Error flashing	○	○	○	○	○	◎	◎	◎	◎	▲	◎	◎																																																																																																																																																																																																																																																																																																																																																																																																																																																																																																																																																																																																																																																																																																																	
Error code	○	○	○	N	○	◎	◎	◎	◎	N	◎	◎																																																																																																																																																																																																																																																																																																																																																																																																																																																																																																																																																																																																																																																																																																																	
Operation hour	N	N	N	N	N	N	N	N	N	N	N	N																																																																																																																																																																																																																																																																																																																																																																																																																																																																																																																																																																																																																																																																																																																	
■Scheduling													One-day	○	○	N	N	N	○	◎	◎	◎	N	◎	◎	Times of ON / OFF per day	1	1	N	1	N	16	24	24	24	24	24	24	Weekly	○	○	N	N	N	○	◎	◎	◎	N	◎	◎	Times of ON / OFF per week	8 x 7	8 x 7	N	N	N	16 x 7	24 x 7	24 x 7	24 x 7	24 x 7	24 x 7	24 x 7	Annual	N	N	N	N	N	N	◎	◎	◎	N	◎	◎	Optimized start-up	N	N	N	N	N	N	○	○	○	N	○	○	Auto-off timer	○	○	N	N	N	N	N	N	N	N	N	N	Min. timer setting unit (minute)	5	5	N	10	N	5	1	1	1	1	N	1	■Recording													Error record	○	N	N	N	N	○	○	○	○	N	○	○	Daily / monthly report	N	N	N	N	N	N	N	N	N	N	N	N	Electricity charge	N	N	N	N	N	N	N	●	N	N	N	N	Energy management data	N	N	N	N	N	N	●	●	●	●	N	●	■Other													Temp-set limitation by Local R/C	○	○	○	N	N	N	N	N	N	N	N	N	Temp-set limitation by System controller *4	○ ^{*6}	○	○ ^{*6}	N	N	○ ^{*6}	N	○ ^{*2*6}	N	○ ^{*2*6}	N	○ ^{*2*6}	Operation-lock	○	○	○	N	◎	N	N	N	N	N	N	N	Night setback	○	○	N	N	N	◎	○ ^{*2}	○ ^{*2}	○ ^{*2}	N	○ ^{*2}	○ ^{*2}	Sliding temperature control	N	N	N	N	N	N	○ ^{*2}	○ ^{*2}	○ ^{*2}	N	○ ^{*2}	○ ^{*2}	BACnet® connection	N	N	N	N	N	N	●	●	●	●	N	N	■Management (Group / Interlocked)													Ventilation interlock	N / ○	N / ○	N / ○	N	○	○	○ / ○ ^{*2}	○ / ○ ^{*2}	N	○ / ○ ^{*2}	○ / ○ ^{*2}	○ / ○ ^{*2}	Group setting	○ ^{*1}	○	○ ^{*1}	N	○	○	○ ^{*2}	○ ^{*2}	N	○ ^{*2}	○ ^{*2}	○ ^{*2}	Block setting	N	N	N	N	N	N	○ ^{*2}	○ ^{*2}	N	○ ^{*2}	○ ^{*2}	○ ^{*2}	Revision of electricity charge	N	N	N	N	N	N	N	N	N	N	N	□ ●	■Operating on LOSSNAY interlocked (Group / Interlocked)													ON / OFF	N / ○	N / ○	N / ○	N / ○ ^{*7}	◎ / ○ ^{*3}	◎ / ◎	◎ / ◎	◎ / ◎	◎ / ◎	▲ / ▲	◎ / ◎	◎ / ◎	Fan speed	N / ○	N / ○	N	N	N	◎ / ◎	◎ / ◎	◎ / ◎	◎ / ◎	N / N	◎ / ◎	◎ / ◎	Ventilation mode	N / N	N	N	N	N	◎ / N	◎ / N	◎ / N	◎ / N	N / N	◎ / N	◎ / N	■Status monitoring on LOSSNAY interlocked (Group / Interlocked)													ON / OFF	N / ○	N / ○	N / ○	N	N	○ / ○	◎ / ◎	◎ / ◎	◎ / ◎	▲ / ▲	◎ / ◎	◎ / ◎	Fan speed	N / ○	N / ○	N	N	N	○ / ○	◎ / ◎	◎ / ◎	◎ / ◎	N / N	◎ / ◎	◎ / ◎	Ventilation mode	N	N	N	N	N	○ / N	◎ / N	◎ / N	◎ / N	N / N	◎ / N	◎ / N																																																																																																																																																																																																																																																																				
One-day	○	○	N	N	N	○	◎	◎	◎	N	◎	◎																																																																																																																																																																																																																																																																																																																																																																																																																																																																																																																																																																																																																																																																																																																	
Times of ON / OFF per day	1	1	N	1	N	16	24	24	24	24	24	24																																																																																																																																																																																																																																																																																																																																																																																																																																																																																																																																																																																																																																																																																																																	
Weekly	○	○	N	N	N	○	◎	◎	◎	N	◎	◎																																																																																																																																																																																																																																																																																																																																																																																																																																																																																																																																																																																																																																																																																																																	
Times of ON / OFF per week	8 x 7	8 x 7	N	N	N	16 x 7	24 x 7	24 x 7	24 x 7	24 x 7	24 x 7	24 x 7																																																																																																																																																																																																																																																																																																																																																																																																																																																																																																																																																																																																																																																																																																																	
Annual	N	N	N	N	N	N	◎	◎	◎	N	◎	◎																																																																																																																																																																																																																																																																																																																																																																																																																																																																																																																																																																																																																																																																																																																	
Optimized start-up	N	N	N	N	N	N	○	○	○	N	○	○																																																																																																																																																																																																																																																																																																																																																																																																																																																																																																																																																																																																																																																																																																																	
Auto-off timer	○	○	N	N	N	N	N	N	N	N	N	N																																																																																																																																																																																																																																																																																																																																																																																																																																																																																																																																																																																																																																																																																																																	
Min. timer setting unit (minute)	5	5	N	10	N	5	1	1	1	1	N	1																																																																																																																																																																																																																																																																																																																																																																																																																																																																																																																																																																																																																																																																																																																	
■Recording													Error record	○	N	N	N	N	○	○	○	○	N	○	○	Daily / monthly report	N	N	N	N	N	N	N	N	N	N	N	N	Electricity charge	N	N	N	N	N	N	N	●	N	N	N	N	Energy management data	N	N	N	N	N	N	●	●	●	●	N	●	■Other													Temp-set limitation by Local R/C	○	○	○	N	N	N	N	N	N	N	N	N	Temp-set limitation by System controller *4	○ ^{*6}	○	○ ^{*6}	N	N	○ ^{*6}	N	○ ^{*2*6}	N	○ ^{*2*6}	N	○ ^{*2*6}	Operation-lock	○	○	○	N	◎	N	N	N	N	N	N	N	Night setback	○	○	N	N	N	◎	○ ^{*2}	○ ^{*2}	○ ^{*2}	N	○ ^{*2}	○ ^{*2}	Sliding temperature control	N	N	N	N	N	N	○ ^{*2}	○ ^{*2}	○ ^{*2}	N	○ ^{*2}	○ ^{*2}	BACnet® connection	N	N	N	N	N	N	●	●	●	●	N	N	■Management (Group / Interlocked)													Ventilation interlock	N / ○	N / ○	N / ○	N	○	○	○ / ○ ^{*2}	○ / ○ ^{*2}	N	○ / ○ ^{*2}	○ / ○ ^{*2}	○ / ○ ^{*2}	Group setting	○ ^{*1}	○	○ ^{*1}	N	○	○	○ ^{*2}	○ ^{*2}	N	○ ^{*2}	○ ^{*2}	○ ^{*2}	Block setting	N	N	N	N	N	N	○ ^{*2}	○ ^{*2}	N	○ ^{*2}	○ ^{*2}	○ ^{*2}	Revision of electricity charge	N	N	N	N	N	N	N	N	N	N	N	□ ●	■Operating on LOSSNAY interlocked (Group / Interlocked)													ON / OFF	N / ○	N / ○	N / ○	N / ○ ^{*7}	◎ / ○ ^{*3}	◎ / ◎	◎ / ◎	◎ / ◎	◎ / ◎	▲ / ▲	◎ / ◎	◎ / ◎	Fan speed	N / ○	N / ○	N	N	N	◎ / ◎	◎ / ◎	◎ / ◎	◎ / ◎	N / N	◎ / ◎	◎ / ◎	Ventilation mode	N / N	N	N	N	N	◎ / N	◎ / N	◎ / N	◎ / N	N / N	◎ / N	◎ / N	■Status monitoring on LOSSNAY interlocked (Group / Interlocked)													ON / OFF	N / ○	N / ○	N / ○	N	N	○ / ○	◎ / ◎	◎ / ◎	◎ / ◎	▲ / ▲	◎ / ◎	◎ / ◎	Fan speed	N / ○	N / ○	N	N	N	○ / ○	◎ / ◎	◎ / ◎	◎ / ◎	N / N	◎ / ◎	◎ / ◎	Ventilation mode	N	N	N	N	N	○ / N	◎ / N	◎ / N	◎ / N	N / N	◎ / N	◎ / N																																																																																																																																																																																																																																																																																																																																																																																									
Error record	○	N	N	N	N	○	○	○	○	N	○	○																																																																																																																																																																																																																																																																																																																																																																																																																																																																																																																																																																																																																																																																																																																	
Daily / monthly report	N	N	N	N	N	N	N	N	N	N	N	N																																																																																																																																																																																																																																																																																																																																																																																																																																																																																																																																																																																																																																																																																																																	
Electricity charge	N	N	N	N	N	N	N	●	N	N	N	N																																																																																																																																																																																																																																																																																																																																																																																																																																																																																																																																																																																																																																																																																																																	
Energy management data	N	N	N	N	N	N	●	●	●	●	N	●																																																																																																																																																																																																																																																																																																																																																																																																																																																																																																																																																																																																																																																																																																																	
■Other													Temp-set limitation by Local R/C	○	○	○	N	N	N	N	N	N	N	N	N	Temp-set limitation by System controller *4	○ ^{*6}	○	○ ^{*6}	N	N	○ ^{*6}	N	○ ^{*2*6}	N	○ ^{*2*6}	N	○ ^{*2*6}	Operation-lock	○	○	○	N	◎	N	N	N	N	N	N	N	Night setback	○	○	N	N	N	◎	○ ^{*2}	○ ^{*2}	○ ^{*2}	N	○ ^{*2}	○ ^{*2}	Sliding temperature control	N	N	N	N	N	N	○ ^{*2}	○ ^{*2}	○ ^{*2}	N	○ ^{*2}	○ ^{*2}	BACnet® connection	N	N	N	N	N	N	●	●	●	●	N	N	■Management (Group / Interlocked)													Ventilation interlock	N / ○	N / ○	N / ○	N	○	○	○ / ○ ^{*2}	○ / ○ ^{*2}	N	○ / ○ ^{*2}	○ / ○ ^{*2}	○ / ○ ^{*2}	Group setting	○ ^{*1}	○	○ ^{*1}	N	○	○	○ ^{*2}	○ ^{*2}	N	○ ^{*2}	○ ^{*2}	○ ^{*2}	Block setting	N	N	N	N	N	N	○ ^{*2}	○ ^{*2}	N	○ ^{*2}	○ ^{*2}	○ ^{*2}	Revision of electricity charge	N	N	N	N	N	N	N	N	N	N	N	□ ●	■Operating on LOSSNAY interlocked (Group / Interlocked)													ON / OFF	N / ○	N / ○	N / ○	N / ○ ^{*7}	◎ / ○ ^{*3}	◎ / ◎	◎ / ◎	◎ / ◎	◎ / ◎	▲ / ▲	◎ / ◎	◎ / ◎	Fan speed	N / ○	N / ○	N	N	N	◎ / ◎	◎ / ◎	◎ / ◎	◎ / ◎	N / N	◎ / ◎	◎ / ◎	Ventilation mode	N / N	N	N	N	N	◎ / N	◎ / N	◎ / N	◎ / N	N / N	◎ / N	◎ / N	■Status monitoring on LOSSNAY interlocked (Group / Interlocked)													ON / OFF	N / ○	N / ○	N / ○	N	N	○ / ○	◎ / ◎	◎ / ◎	◎ / ◎	▲ / ▲	◎ / ◎	◎ / ◎	Fan speed	N / ○	N / ○	N	N	N	○ / ○	◎ / ◎	◎ / ◎	◎ / ◎	N / N	◎ / ◎	◎ / ◎	Ventilation mode	N	N	N	N	N	○ / N	◎ / N	◎ / N	◎ / N	N / N	◎ / N	◎ / N																																																																																																																																																																																																																																																																																																																																																																																																																																																										
Temp-set limitation by Local R/C	○	○	○	N	N	N	N	N	N	N	N	N																																																																																																																																																																																																																																																																																																																																																																																																																																																																																																																																																																																																																																																																																																																	
Temp-set limitation by System controller *4	○ ^{*6}	○	○ ^{*6}	N	N	○ ^{*6}	N	○ ^{*2*6}	N	○ ^{*2*6}	N	○ ^{*2*6}																																																																																																																																																																																																																																																																																																																																																																																																																																																																																																																																																																																																																																																																																																																	
Operation-lock	○	○	○	N	◎	N	N	N	N	N	N	N																																																																																																																																																																																																																																																																																																																																																																																																																																																																																																																																																																																																																																																																																																																	
Night setback	○	○	N	N	N	◎	○ ^{*2}	○ ^{*2}	○ ^{*2}	N	○ ^{*2}	○ ^{*2}																																																																																																																																																																																																																																																																																																																																																																																																																																																																																																																																																																																																																																																																																																																	
Sliding temperature control	N	N	N	N	N	N	○ ^{*2}	○ ^{*2}	○ ^{*2}	N	○ ^{*2}	○ ^{*2}																																																																																																																																																																																																																																																																																																																																																																																																																																																																																																																																																																																																																																																																																																																	
BACnet® connection	N	N	N	N	N	N	●	●	●	●	N	N																																																																																																																																																																																																																																																																																																																																																																																																																																																																																																																																																																																																																																																																																																																	
■Management (Group / Interlocked)													Ventilation interlock	N / ○	N / ○	N / ○	N	○	○	○ / ○ ^{*2}	○ / ○ ^{*2}	N	○ / ○ ^{*2}	○ / ○ ^{*2}	○ / ○ ^{*2}	Group setting	○ ^{*1}	○	○ ^{*1}	N	○	○	○ ^{*2}	○ ^{*2}	N	○ ^{*2}	○ ^{*2}	○ ^{*2}	Block setting	N	N	N	N	N	N	○ ^{*2}	○ ^{*2}	N	○ ^{*2}	○ ^{*2}	○ ^{*2}	Revision of electricity charge	N	N	N	N	N	N	N	N	N	N	N	□ ●	■Operating on LOSSNAY interlocked (Group / Interlocked)													ON / OFF	N / ○	N / ○	N / ○	N / ○ ^{*7}	◎ / ○ ^{*3}	◎ / ◎	◎ / ◎	◎ / ◎	◎ / ◎	▲ / ▲	◎ / ◎	◎ / ◎	Fan speed	N / ○	N / ○	N	N	N	◎ / ◎	◎ / ◎	◎ / ◎	◎ / ◎	N / N	◎ / ◎	◎ / ◎	Ventilation mode	N / N	N	N	N	N	◎ / N	◎ / N	◎ / N	◎ / N	N / N	◎ / N	◎ / N	■Status monitoring on LOSSNAY interlocked (Group / Interlocked)													ON / OFF	N / ○	N / ○	N / ○	N	N	○ / ○	◎ / ◎	◎ / ◎	◎ / ◎	▲ / ▲	◎ / ◎	◎ / ◎	Fan speed	N / ○	N / ○	N	N	N	○ / ○	◎ / ◎	◎ / ◎	◎ / ◎	N / N	◎ / ◎	◎ / ◎	Ventilation mode	N	N	N	N	N	○ / N	◎ / N	◎ / N	◎ / N	N / N	◎ / N	◎ / N																																																																																																																																																																																																																																																																																																																																																																																																																																																																																																																																																					
Ventilation interlock	N / ○	N / ○	N / ○	N	○	○	○ / ○ ^{*2}	○ / ○ ^{*2}	N	○ / ○ ^{*2}	○ / ○ ^{*2}	○ / ○ ^{*2}																																																																																																																																																																																																																																																																																																																																																																																																																																																																																																																																																																																																																																																																																																																	
Group setting	○ ^{*1}	○	○ ^{*1}	N	○	○	○ ^{*2}	○ ^{*2}	N	○ ^{*2}	○ ^{*2}	○ ^{*2}																																																																																																																																																																																																																																																																																																																																																																																																																																																																																																																																																																																																																																																																																																																	
Block setting	N	N	N	N	N	N	○ ^{*2}	○ ^{*2}	N	○ ^{*2}	○ ^{*2}	○ ^{*2}																																																																																																																																																																																																																																																																																																																																																																																																																																																																																																																																																																																																																																																																																																																	
Revision of electricity charge	N	N	N	N	N	N	N	N	N	N	N	□ ●																																																																																																																																																																																																																																																																																																																																																																																																																																																																																																																																																																																																																																																																																																																	
■Operating on LOSSNAY interlocked (Group / Interlocked)													ON / OFF	N / ○	N / ○	N / ○	N / ○ ^{*7}	◎ / ○ ^{*3}	◎ / ◎	◎ / ◎	◎ / ◎	◎ / ◎	▲ / ▲	◎ / ◎	◎ / ◎	Fan speed	N / ○	N / ○	N	N	N	◎ / ◎	◎ / ◎	◎ / ◎	◎ / ◎	N / N	◎ / ◎	◎ / ◎	Ventilation mode	N / N	N	N	N	N	◎ / N	◎ / N	◎ / N	◎ / N	N / N	◎ / N	◎ / N	■Status monitoring on LOSSNAY interlocked (Group / Interlocked)													ON / OFF	N / ○	N / ○	N / ○	N	N	○ / ○	◎ / ◎	◎ / ◎	◎ / ◎	▲ / ▲	◎ / ◎	◎ / ◎	Fan speed	N / ○	N / ○	N	N	N	○ / ○	◎ / ◎	◎ / ◎	◎ / ◎	N / N	◎ / ◎	◎ / ◎	Ventilation mode	N	N	N	N	N	○ / N	◎ / N	◎ / N	◎ / N	N / N	◎ / N	◎ / N																																																																																																																																																																																																																																																																																																																																																																																																																																																																																																																																																																																																																						
ON / OFF	N / ○	N / ○	N / ○	N / ○ ^{*7}	◎ / ○ ^{*3}	◎ / ◎	◎ / ◎	◎ / ◎	◎ / ◎	▲ / ▲	◎ / ◎	◎ / ◎																																																																																																																																																																																																																																																																																																																																																																																																																																																																																																																																																																																																																																																																																																																	
Fan speed	N / ○	N / ○	N	N	N	◎ / ◎	◎ / ◎	◎ / ◎	◎ / ◎	N / N	◎ / ◎	◎ / ◎																																																																																																																																																																																																																																																																																																																																																																																																																																																																																																																																																																																																																																																																																																																	
Ventilation mode	N / N	N	N	N	N	◎ / N	◎ / N	◎ / N	◎ / N	N / N	◎ / N	◎ / N																																																																																																																																																																																																																																																																																																																																																																																																																																																																																																																																																																																																																																																																																																																	
■Status monitoring on LOSSNAY interlocked (Group / Interlocked)													ON / OFF	N / ○	N / ○	N / ○	N	N	○ / ○	◎ / ◎	◎ / ◎	◎ / ◎	▲ / ▲	◎ / ◎	◎ / ◎	Fan speed	N / ○	N / ○	N	N	N	○ / ○	◎ / ◎	◎ / ◎	◎ / ◎	N / N	◎ / ◎	◎ / ◎	Ventilation mode	N	N	N	N	N	○ / N	◎ / N	◎ / N	◎ / N	N / N	◎ / N	◎ / N																																																																																																																																																																																																																																																																																																																																																																																																																																																																																																																																																																																																																																																																										
ON / OFF	N / ○	N / ○	N / ○	N	N	○ / ○	◎ / ◎	◎ / ◎	◎ / ◎	▲ / ▲	◎ / ◎	◎ / ◎																																																																																																																																																																																																																																																																																																																																																																																																																																																																																																																																																																																																																																																																																																																	
Fan speed	N / ○	N / ○	N	N	N	○ / ○	◎ / ◎	◎ / ◎	◎ / ◎	N / N	◎ / ◎	◎ / ◎																																																																																																																																																																																																																																																																																																																																																																																																																																																																																																																																																																																																																																																																																																																	
Ventilation mode	N	N	N	N	N	○ / N	◎ / N	◎ / N	◎ / N	N / N	◎ / N	◎ / N																																																																																																																																																																																																																																																																																																																																																																																																																																																																																																																																																																																																																																																																																																																	

◎: Each group / Batched ; ○: Each group ; □: Block (for CITY MULTI Indoor unit, not for all Mr.SLIM) ; ●: AE-200E/AE-50E/EW-50E/AG-150A license registration possible.
 (●): License registration for the optional functions required N: Not Available (Not Used.) ▲: Batched only ; ▲: Batched handling (for maintenance) ■: Block

*1. Group setting via wiring between Indoor units with cross-over cable;
 *2. Installation possible at initial setting web browser;
 *3. Inter-lock is set at Local remote controller.
 *4. AG-150A license registration to AG-150A is required to monitor and operate the units by browser and TG-2000A. AE-200, AE-50, and EW-50 are standard equipped with the Web Browser. No license registration is required.
 5. AG-150A connected with PAC-YG50ECA is compatible with TG-2000A Ver.6.10 or later. AE-200E/AE-50E is compatible with TG-2000A Ver. 6.50A or later. EW-50E is compatible with TG-2000A Ver.6.60 or later.
 *6. This function can be set only on the ME remote controller. This function cannot be used with the MA/Simple MA remote controller. (But, the validity of this function with the MA/Simple MA remote controller depends on the indoor unit model, and there are possibilities that this function can be used with them.)
 *7. Inter-lock is set from system controllers (Except PAC-YT40ANRA) or local remote controllers.
 *8. The maximum number of controllable units decreases depending on the indoor unit model.
 *9. For indoor use only.
 *10. This function is supported only when all the indoor units, remote controllers, and system controllers that are connected to a given group features the function.
 *11. For the availability of the function, please contact your local distributor.
 *12. BAC-HD150 ver. 2.10 and later supports the dual set point function.

Air conditioner control system interface
LMAP04-E: LonWorks® Interface
 Controls up to 50 Groups/ 50 units, for details, refer to its description.
BAC-HD150: BACnet® Interface
 Controls up to 50 Groups/ 50 units, up to 150 Groups/ 150 units with three expansion controllers, for details, refer to its description. *12

Remote Controller

Individual Remote Controller



Wired MA remote controller PAR-32MAA



Dimensions: 120(W) x 120(H) x 19(D) mm
: 4-3/4(W) x 4-3/4(H) x 3/4(D) in.

Example of system configuration

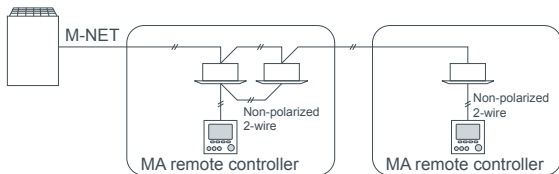

*When a PAR-32MAA is connected to a group, no other MA remote controllers can be connected to the same group.

• Draft reduction

“Close” has been added to the manual vane angle selection. The air outlet can be closed to reduce drafts from the air conditioner.

• Auto descending panel*

Panels can be lowered/raised using the remote controller. The descending distance of the panel can also be selected.

*The availability of the function depends on the indoor unit model. For details, please contact your local distributor.

- Temperature will be displayed either in Centigrade in 0.5- or 1-degree increments, or in Fahrenheit, depending on the indoor unit model and the display mode setting on the remote controller.

• Backlit LCD (Liquid Crystal Display)

Large, easy-to-see display
Full-dot LCD display with large characters for easy viewing
Contrast also adjustable

• Night Setback

To prevent indoor dew or excessive temperature rise, this control starts heating operation when the control object group is stopped and the room temperature drops below the preset lower limit temperature. Also, this control starts cooling operation when the control object group is stopped and the room temperature rises above the preset upper limit temperature.

• Language selection

Language to be displayed on the screen can be selected from 8 languages.

English, French, Spanish, Italian, Portuguese, Greek, Turkish, Swedish

• 3D i-See sensor

Settings for 3D i-See sensor can be made.

Functions

		○: Each group ×: Not available	
Item	Description	Operations	Display
ON/OFF	Switches between ON and OFF.	○	○
Operation mode switching	Switches among Cool/Dry/Fan/Auto/Heat.	○	○
Room temp. setting	The temperature can be set within the following range. Cool/Drying : 19°C - 35°C/67°F - 95°F Heat : 4.5°C - 28°C/40°F - 83°F Auto (single set point) : 19°C - 28°C/67°F - 83°F Auto (dual set points) [Cool] Same as the set temp. range for Cool mode. [Heat] Same as the set temp. range for Heat mode. * Set temperature range varies depending on the model.	○	○
Air flow direction setting	Changes airflow direction. * Available airflow directions vary depending on the model.	○	○
Louver setting	Switches between louver ON/OFF.	○	○
Ventilation equipment control	Interlocked setting and interlocked operation setting with the CITY MULTI LOSSNAY units can be made. The Stop/Low/High settings of the ventilation equipment can be controlled.	○	○
Error information	When an error occurs, an error code and the unit address appear. Air conditioning unit model, serial number, and contact number can be set to appear when an error occurs. (The information above needs to be entered in advance.) * An error code may not appear depending on the error.	—	○
Timer	ON/OFF timer Turns ON and OFF daily at a set time. • Time can be set in 5-minute increments. • It is also possible to set the ON time only or the OFF time only. Auto-OFF timer Turns off the unit after a certain period of operation. • Operation time can be set to a value from 30 to 240 minutes in 10-minute increments.	○	○
Allows/disallows local operation	The following operation can be prohibited by making certain settings on the centralized controller: ON/OFF, operation mode setting, temperature setting, fan speed, air direction, and filter sign reset. * While an operation is prohibited, the operation icon lights up (only on the Main display in the "Full" mode).	×	○
Operation lock	The following operation can be prohibited respectively: ON/OFF, operation mode setting, temperature setting, and airflow direction setting.	○	○
Temperature range restriction	The room temperature range for each operation mode can be restricted.	○	○
Auto return	The units operate at the preset temperature after a designated period. (Time can be set to a value from 30 to 120 in 10-minute increments.) * Not valid when the temperature setting range is restricted.	○	×

Individual Remote Controller

ME remote controller PAR-U02MEDA

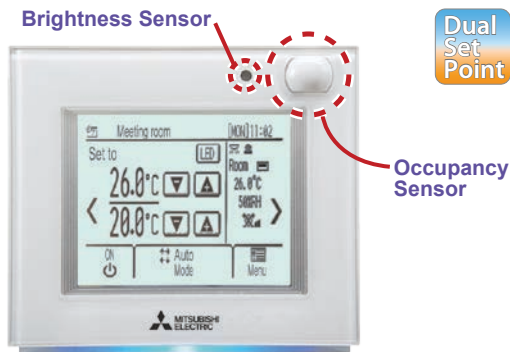

Dimensions : 140(W) x 120(H) x 25(D) mm
: 5-9/16(W) x 4-3/4(H) x 1(D) in.

- **Occupancy Sensor**
The occupancy sensor detects vacancy for energy-save control.
- **Touch Panel & Backlit LCD**
The touch panel shows the operation settings screen. When the backlight is off, touching the panel turns the backlight on, and it will stay lit for a predetermined period of time.
- **LED Indicator**
The LED indicator indicates the operation status in different colors. The LED indicator lights up during normal operation, turns off when units are stopped, and blinks when an error occurs.
- **Brightness Sensor**
The brightness sensor detects the brightness of the room for energy-save control.
- **Temperature & Humidity Sensor**
The sensor detects the room temperature and the relative humidity.
- **Device control via AHC (Advanced HVAC Controller)**
Allows for control of other manufacturer's products connected via AHC.
- **Auto (Dual Set Point) Modes**
Two set temperatures (one each for cooling and heating) can be set.

Example of system configuration

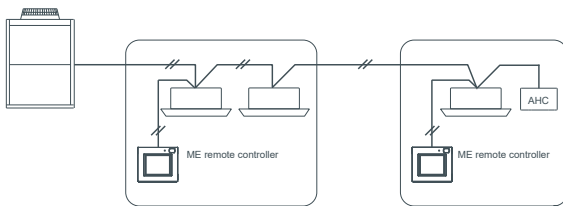

Occupancy Sensor detection zone

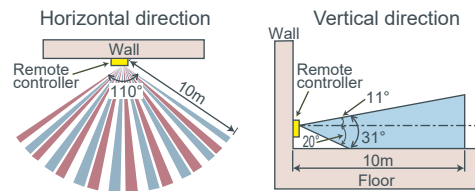

Functions

○:Each group ×:Not available

Item	Description	Operations	Display
ON/OFF	Switches between ON and OFF.	○	○
Operation mode switching	Switches between Cool / Drying / Fan / Heat / Auto. Operation modes vary depending on the indoor unit model. Auto mode is for CITY MULTI R2, and WR2 series only.	○	○
Temperature setting	The temperature can be set within the following range. Cool / Drying : 19°C - 35°C / 67°F - 95°F Heat : 4.5°C - 28°C / 40°F - 83°F Auto : (single set point) : 19°C - 28°C / 67°F - 83°F Auto : (dual set points) [Cool] Same as the set temp. range for Cool mode. [Heat] Same as the set temp. range for Heat mode. * The settable temperature ranges vary depending on the indoor unit model.	○	○
Fan speed setting	Changes fan speed. * Available fan speeds vary depending on the model.	○	○
Air flow direction setting	Changes airflow direction. * Available airflow directions vary depending on the model.	○	○
Allows/disallows local operation	The following operation can be prohibited by making certain settings on the centralized controller: ON/OFF, operation mode setting, temperature setting, fan speed, air direction, and filter sign reset. * While an operation is prohibited, the operation icon lights up.	×	○
Error information	When an error occurs, an error code and the unit address appear. Contact number can be set to appear when an error occurs. (The information above needs to be entered on the Service menu.)	—	○
Schedule (Weekly timer)	Weekly ON/OFF times, operation mode, and set temperatures can be set. • Time can be set in 5-minute increments. Up to 8 schedule patterns can be set per day of the week. * Not valid when the ON/OFF timer is set.	○	○
Timer	ON/OFF timer Turns ON and OFF daily at a set time. • Time can be set in 5-minute increments. • It is also possible to set the ON time only or the OFF time only. Auto-OFF timer Turns off the unit after a certain period of operation. • Operation time can be set to a value from 30 to 240 in 10-minute increments.	○	○
Energy-save control during vacancy	When vacancy is detected by the occupancy sensor, the energy-save control assist function is activated. Four control types are available for selection: ON/OFF/Set temperature/Fan speed/Thermo-off. The brightness sensor can be used in conjunction with the occupancy sensor to detect the occupancy/vacancy status more accurately.	○	○

Individual Remote Controller

Simple remote controller PAC-YT52CRA (MA)



Dimensions: 70(W) x 120(H) x 14.5(D) mm
: 2-3/4(W) x 4-23/32(H) x 9/16(D) in.

Example of system configuration

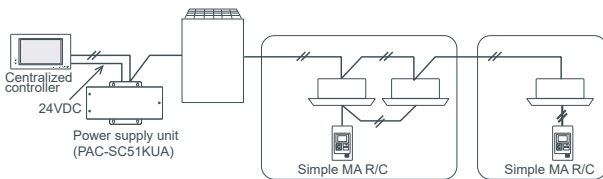

• Dual Set Point

When the operation mode is set to the Auto (dual set point) mode, two preset temperatures (one each for cooling and heating) can be set. Depending on the room temperature, indoor unit will automatically operate in either the Cool or Heat mode and keep the room temperature within the preset range.

*Please contact your Mitsubishi Electric sales office for details.

• Backlit LCD

Backlight for operation in dark places

• Flat Back

Slim, flat design - install without creating a hole in the wall
Thickness is less than 14.5mm [0.6(in)]

• Vane Button (standard)

The Vane button has been added to allow the user to change airflow direction (ceiling-cassette and wall-mounted types).

Pressing the  button will switch the vane directions.



*The settable vane direction varies depending on the indoor unit model to be connected.

* If the unit has no vane function, the vane direction cannot be set.

In this case, the vane icon blinks when the  button is pressed.

• The only wiring required is cross-over wiring based on two-wire signal lines

• Room temperature sensors are built-in

• Can operate all types of indoor units

*Since this controller has limited functions, it should always be used in conjunction with standard controller or centralized controller.

• LCD temperature setting and display in 1°C /1°F increments

Functions

Item	Description	Operations Display	
		□: Each unit	○: Each group
ON/OFF	Changes between ON and OFF.	○	○
Operation mode switching	Select from COOL, DRYING, FAN, AUTO, and HEAT. * AUTO mode is settable only when those functions are available on the indoor unit.	○	○
Temperature setting	The temperature can be set within the following range. Cool/Drying : 19°C - 35°C/67°F - 95°F Heat : 4.5°C - 28°C/40°F - 83°F Auto (single set point) : 19°C - 28°C/67°F - 83°F Auto (dual set points) [Cool] Same as the set temp. range for Cool mode. [Heat] Same as the set temp. range for Heat mode. * Set temperature range varies depending on the model.	○	○
Fan speed setting	Changes the fan speed. * The settable fan speed varies depending on the indoor unit model to be connected.	○	○
Permit / Prohibit local operation	By setting a centralized controller, the following local operations are prohibited: ON/OFF; operation mode; preset temperature; * The CENTRAL icon appears while the local operations are prohibited.	×	○
Error	Displays the current error status with the address. * The address may not be displayed depending on the error status.	×	□
Ventilation equipment	When the CITY MULTI indoor unit is connected, interlocked setting of the CITY MULTI LOSSNAY unit is possible. When the Mr. SLIM indoor unit (A-control) is connected, interlocked operation of the microcomputer-type LOSSNAY unit is possible.	○	○
Set temperature range limit	The preset temperature range can be restricted for each operation mode (COOL/HEAT/AUTO).	○	○

Wireless remote controller PAR-FL32MA / PAR-FA32MA / PAR-SA9FA



PAR-FL32MA

Dimensions: 58(W) x 159(H) x 19(D) mm
: 2-5/16(W) x 6-5/16(H) x 3/4(D) in.



PAR-FA32MA

Dimensions: 70(W) x 120(H) x 22.5(D) mm
: 2-3/4(W) x 4-3/4(H) x 7/8(D) in.



PAR-SA9FA-E
(4-way Cassette signal receiver)

Dimensions: 256(H) x 19(D) mm



PAR-SL94B-E

(Wireless remote controller kit for ceiling suspended)

Dimensions: 182(W) x 57(H) x 31(D) mm

- No need to configure addresses for group operation
- Lit LED keeps you informed of operation - blinking even gives you the error code via the number of blinks
- Can be used with the MA remote controller
 - *When used in group configurations, wiring between indoor units is required.
 - *Combining ME remote controller and/or LOSSNAY remote controller in a group is not possible.
- LCD temperature setting and display in 1°C /1°F increments

Example of system configuration

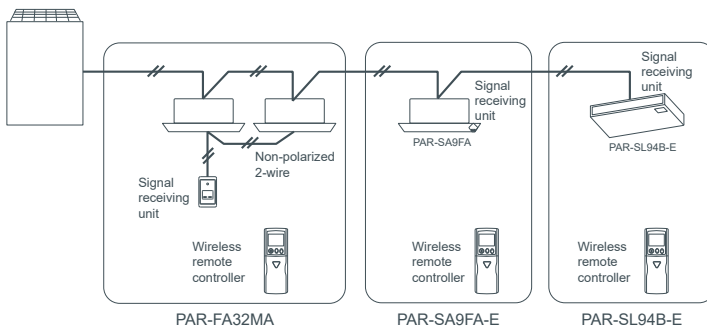

Correspondence table

	receiver	transmitter
PMFY-P VBM PLFY-P VCM/VLMD PFFY-P VKM PEFY-P VMR-E-L/R/VMH PFFY-P VLEM/VKM/VLRM/VLRMM PEFY-P VMS1(L) PEFY-VMA(L)	PAR-FA32MA	PAR-FL32MA
PCFY-P VKM	PAR-FA32MA PAR-SL94B-E	
PLFY-P VBM-E	PAR-SA9FA-E	
PKFY-P VBM-E PKFY-P VHM/VKM	Built-in	

Functions

Item	Description	Operations	Display
ON/OFF	ON and OFF operation for a single group	○	○
Temperature setting	Sets the temperature for a single group Range of temperature setting Cool/Dry : 19°C - 30°C (14°C - 30°C) / 67°F - 87°F (57°F - 87°F) Heat : 17°C - 28°C (17°C - 28°C) / 63°F - 83°F (63°F - 83°F) Auto : 19°C - 28°C (17°C - 28°C) / 67°F - 83°F (63°F - 83°F) () For PEFY/PFFY by setting DipSW 7-1 to ON and limits to Ni6H fan speed only. * Set to PAR-FL32MA according to its Installation Manual 4 "Model setting".	○	○
Air flow direction setting	Air flow direction angles (4-angle, Swing) Auto Louver ON/OFF. Air flow direction settings vary depending on the model.	*	*
Timer operation	One ON/OFF setting can be set for one day.	○	○
Permit / Prohibit local operation	Individually prohibit operation of each local remote control function (ON/OFF, Change operation mode, Set temperature, Reset filter). *1 If operation is performed when the local remote controller inactivation command is received from the main system controller, a buzzer will ring and an LED will flash.	X	○ ^{*1}
Ventilation equipment	Up to 16 indoor units can be connected to an interlocked system that has one LOSSNAY. The LOSSNAY will run in interlock with the operation of indoor unit. *2 The fan rate and mode cannot be changed.	X ^{*2}	X

*Some models will have different display for the air flow direction and fan speed. Set the air flow direction and fan speed when performing initial setting.

Remote Controller

Centralised Remote Controller

With our new Advanced Touch Controller AT-50B, easy and simple operation on the touch panel offers an optimal air environment for individual unit.

Advanced Touch controller AT-50B



Dimensions: 180(W) x 120(H) x 30(D) mm
: 7-2/16(W) x 4-12/16(H) x 1-3/16(D) in.



- Temperature will be displayed either in Centigrade in 0.5- or 1-degree increments, or in Fahrenheit, depending on the indoor unit model and the display mode setting on the remote controller

- **Dual set point**
When the operation mode is set to the Auto (dual set point) mode, two preset temperatures (one each for cooling and heating) can be set. Depending on the room temperature, indoor unit will automatically operate in either the Cool or Heat mode and keep the room temperature within the preset range.

*Please contact your Mitsubishi Electric sales office for details.

System structure

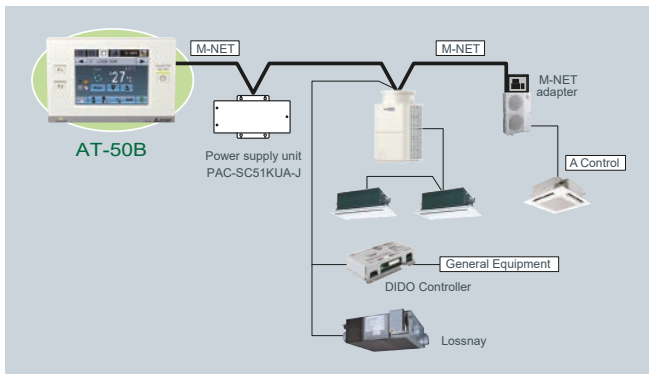

Operation pattern during Auto (dual set point) mode

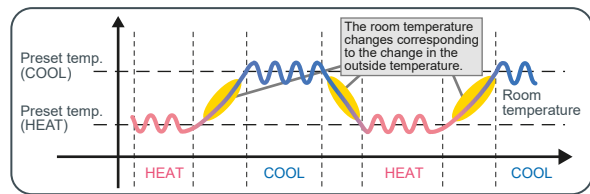

Design

Backlit LCD (Liquid Crystal Display) Touch Panel

5-inch color LCD touch panel enables easy and simple operation.

The backlight lights up when the panel is touched, and lights off after certain period of time.

The touch panel displays the operation status of the units in GRID, LIST or in GROUP.

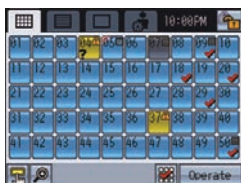

GRID (zoom-out) screen
Displays the operation status of all groups.



GRID (zoom-in) screen
Displays the detailed operation status of each group.



LIST screen
Displays the detailed operation status of each group with group name.



GROUP screen
Displays the detailed operation status of each group. Sets group operations.

Functions

Three in one

The following three features are integrated into AT-50B.

- Control up to 50 indoor units from one location
- A weekly programmable timer, being able to control up to 50 indoor units
- Control up to 50 units/50 groups of air conditioners

Weekly and daily schedule

5 patterns of one day and 12 patterns of weekly schedule (16 settings max. per pattern).

Two types of weekly schedule can be set.

System changeover

Operation mode can be switched depending on indoor temperature setting and target temperature of each group or a representative indoor unit.

Night setback function

This function allows having a two-temperature setting to keep the desired room temperature when the units are not in operation and during the time this function is effective. The unit automatically starts heating (cooling) operation when the temperature drops below (rises above) the preset lower (upper) limit temperature. This is not only for comfort environment, but also for saving energy.

Main system controller/Sub system controller

AT-50B can be set to Sub System controller.

When connecting multiple system controllers, designate the system controller with many functions as the "Main", and set the system controllers with few functions as the "Sub".

Simple button arrangement

The F1 (Function 1) and the F2 (Function 2) button can be set as a run button of the following collective operation. (Setback/Schedule/Operation Mode/Temperature Correction/Remote Controller Prohibition)

Functions

[Basic Functions]

- ON/OFF ▪ Operation mode switching
- Temperature setting ▪ Fan speed setting
- Airflow direction setting ▪ Louver setting

Advanced Functions

□: Each unit ○: Each group ⊙: Group or collective ×: Not available			
Item	Description	Operations	Display
Permit / Prohibit	The ON/OFF, operation mode, setting temperature, fan speed, air direction, filter sign reset operations, and timer using the local remote controllers can be prohibited. Only ON/OFF and filter reset can be prohibited for the LOSSNAY group. *The settable items vary depending on the models.	⊙	⊙
Operation lock	The operation lock can be set to the input operation of AT-50B. Each button can be set. (Function Button 1, Function Button 2, Collective ON/OFF, Touch Panel) Each function can be set. (Operation mode, Setting temperature, Fan speed, Menu button) The password for the lock release can be set.	⊙	⊙
Error display	When an error is currently occurring on an air conditioner unit, the afflicted unit and the error code are displayed. * When an error occurs, the "ON/OFF" LED flashes. The operation monitor screen show abnormal icon over the unit. The error monitor screen shows the abnormal unit address and error code. The error log monitor screen shows the time and date, the abnormal unit address, error code and source of detection.	×	□ ⊙
Ventilation (independent)	Switches the mode "Bypass/Heat recovery/Auto" for LOSSNAY groups.	⊙	⊙
Ventilation (interlocked)	The LOSSNAY will run in interlock with the operation of indoor unit. The mode cannot be changed. The LED will turn ON during operation after interlocking.	⊙	⊙
Temperature-set limitation	Batch-setting to temperature range limit at cooling, heating, and auto mode. This function cannot be used with the MA remote controller. (Depends on the indoor unit model.)	⊙	⊙
Specific mode operation prohibit (Cooling prohibit, heating prohibit, cooling/heating prohibit)	When set as the main controller, operation of the following modes with the local remote controllers can be prohibited. When cooling is prohibited: Cooling, dry, automatic can not be chosen. When heating is prohibited: Heating, automatic can not be chosen. When cooling/heating is prohibited: Cooling, dry, heating, automatic can not be chosen.	⊙	⊙
External input (Emergency stop input, etc.)	The following input with level signals or pulse signals are available. Level signal: "Emergency stop input" or "Collective ON/OFF" Pulse signal: "Collective ON/OFF" or "Local remote controller prohibit/permit" One input can be selected from those above. * An external input/output adapter (PAC-YT51HAA (sold separately)) is required. Relays and DC power supply or other devices must be prepared at the site.	⊙	⊙
External output (Error output, operation output)	"ON/OFF" and "error/normal" are output with the level signal. * An external input/output adapter (PAC-YT51HAA (sold separately)) is required. Relays and DC power supply or other devices must be prepared at the site.	⊙	⊙
Checking the Gas Amount	Use this function to check for refrigerant leak from the outdoor unit. * When this function is used, the gas amount checking function of the outdoor unit cannot be used. This function is for CITY MULTI R2 and Y (PUMY is excluded.) series only.	□	□
Schedule operation	Weekly schedule setting up to 12 pattern is available. In one pattern, up to 16 setting of "ON/OFF", "Operation mode", "Set Temperature", "Fan speed", "Air flow direction" and "Permit / Prohibit local operation" can be scheduled. Two types of weekly schedule(Summer/Winter) can be set. Today's schedule setting up to 5 pattern is available.	⊙	⊙

* Depending on the installation conditions, power supply unit (PAC-SC51KUA) is required. Please contact your local distributor or MITSUBISHI ELECTRIC branch office for further information.

Remote Controller

Centralised Remote Controller

NEW

Centralised controller AE-200E/AE-50E



Dual Set Point

Dimensions: 284(W) x 200(H) x 65(D) mm
: 11-5/32(W) x 7-27/32(H) x 2-9/16(D) in.

Control Screen for Power Consumption



Energy consumption of applicable area is displayed by the month, day, and hour. Energy consumption of two different units, groups and blocks can be compared. Fan operation time as well as energy consumption can be displayed.

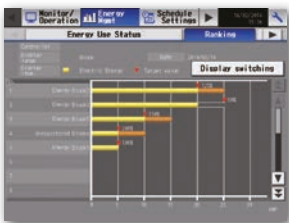

Energy consumptions of air-conditioning equipment are ranked and displayed by individual air-conditioning equipment and by area, thus visualising high-load components. Also, comparison of energy consumption with target electric energy is possible.

- **Comprehensively showing the energy consumption of air conditioning equipment, assisting in energy saving**
 - Energy consumption of air-conditioning equipment by individual area is displayed using graphs for easier viewing
 - Enables comparisons with the previous year's power consumption as well as with the target electric power, thus allowing users to check the operating state at a glance
 - Floor layout is displayed on the 10.4-inch LCD touch panel, facilitating easier operation of air-conditioning equipment
- **In an easy and flexible manner, an optimum system can be established according to the scale of facilities**
 - Implements control on up to 50 indoor units of air-conditioning equipment
 - By using three units of expansion controller "AE-50E", the centralised control is implemented for the maximum of 200 indoor units
 - Connection with PC allows implementation of control on more than 200 indoor units via Web browser^{*1}
 - *1. Please contact your local distributor for when the feature is supported.
- **Features for operating and monitoring the hot water heat pump are also available on CAHV, PWFY, and CRHV^{*2}**
 - Centralised batch control on CAHV, PWFY, and CRHV^{*2} is possible in addition to that on air-conditioning unit
 - *2. Please contact your local distributor for when these features are supported on CRHV.

Number of connectable units

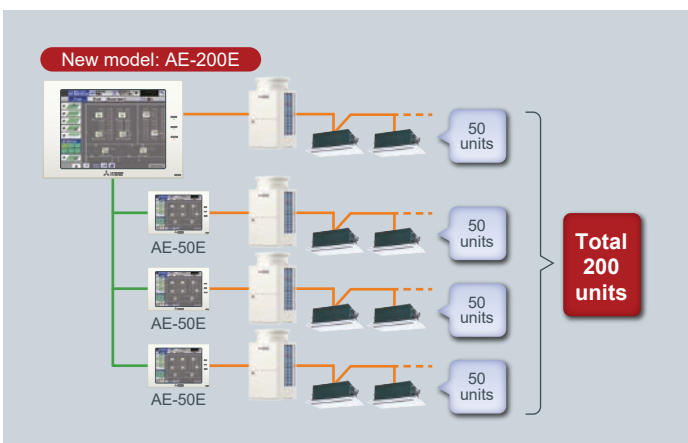

System Structure

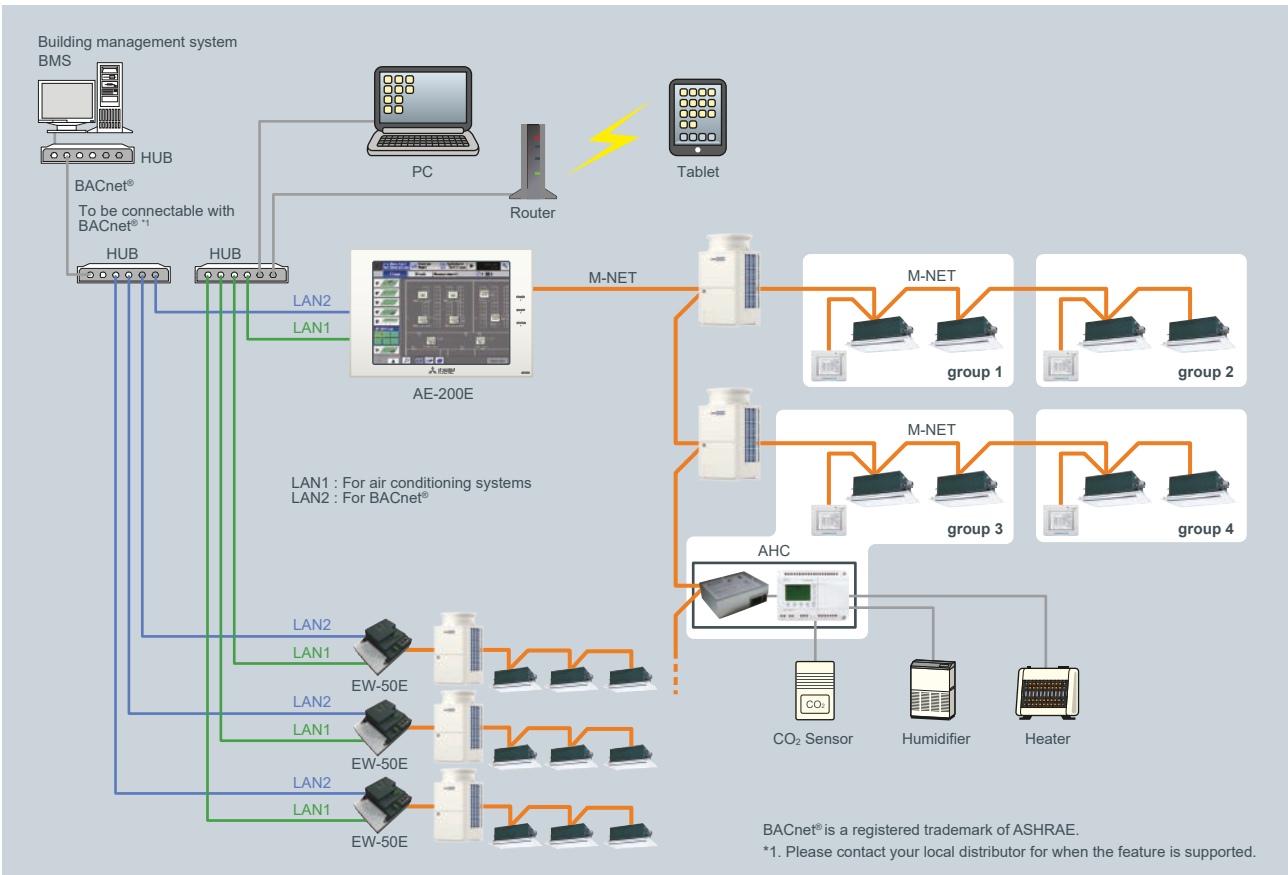

Functions

Item	Description	Operations	Display
Controllable number of unit	Up to 50 units/50 groups		
ON/OFF	ON and OFF operation for the air conditioning units and general equipment. (To operate general equipment, PAC-YG66DCA is required.)	○ ○ △ ●	○ ○
Operation mode	Switches between several operation modes depending on the air conditioning unit. Air conditioning unit : Cool/Dry/Auto(*)/Fan/Heat LOSSNAY unit : Heat Recovery/Bypass/Auto CAHV, CRHV, Air To Water (PWFY) units : Heating, Heating ECO, Hot Water, Anti-freeze, Cooling(**) * Auto mode is for CITY MULTI R2 and WR2 series only. ** Only PWFY	○ ○ △ ●	○
Temperature setting	Cool/Dry : 19°C (67°F) -35°C (95°F) [14°C (57°F) -30°C (87°F)] Heat : 4.5°C (40°F) -28°C (83°F) [17°C (63°F) -28°C (83°F)] Auto : 19°C (67°F) -28°C (83°F) [17°C (63°F) -28°C (83°F)] The range of temperature depends on the air conditioning unit. [] in case of using middle-temperature on PDFY, PEFY-VML/VMR/VMS/VMH-by setting DipSW7-1 to ON. Yet, PEFY-P-VMH-E-F is excluded.	○ ○ △ ●	○
Fan speed setting	Models with 4 air flow speed settings : Hi/Mid-2/Mid-1/Low Models with 3 air flow speed settings : Hi/Mid/Low Models with 2 air flow speed settings : Hi/Low Fan speed setting (including Auto) varies depending on the model.	○ ○ △ ●	○
Air flow direction setting	Air flow direction angles, 4-angles or 5-angles Swing, Auto (Louver cannot be set)	○ ○ △ ●	○
Schedule operation	Weekly schedule can be set by groups based on daily operation pattern.	○ ○ △ ●	○
Permit/prohibit local operation	Individually prohibits operation of each local remote controller function. (ON/OFF, Operation mode, Set temperature, Filter sign reset, Air Direction*, Fan Speed*, Timer*) * This function depends on the model.	○ ○ △ ●	○
Indoor unit intake temperature	Measures the intake temperature of the indoor unit only when the indoor unit is operating.	×	○
Error	When an error is currently occurring on an air conditioning unit, the afflicted unit and the error code are displayed.	×	□ ○
Test run	This operates air conditioning units in test run mode.	○ ○ △ ●	○
Ventilation interlock	The ventilation unit (LOSSNAY) is able to automatically start its operation when operation of the interlocked indoor unit starts.	○ ○ △ ●	○
External input/output	By using optional external input/output adapter (PAC-YG10HA-E) you can set and monitor the following. Input : By level signal : "Batch ON/OFF", "Batch emergency stop" By pulse signal : "Batch ON/OFF", "Enable/disable local remote controller" Output : "ON/OFF", "Error/Normal"	○	○
Energy Management	Bar Graph : Indoor unit Electric Energy, FAN operation time, Thermo-ON time (TOTAL, Cooling, Heating) can be displayed hourly, daily and monthly. Line Graph : Outdoor temp., Room temp., Set temp. (Heating, Cooling) input from PAC-YG63MCA and temp. from AHC.	×	□ ○ ●
Advanced HVAC Controller (AHC)	The status of AHC can only be monitored.	×	○
New Smart ME controller	The status of sensor on this controller can be monitored.	×	○
Smartphone/Tablet	The specified Web browser on iOS and Android OS can monitor and operate AE-200E. *1	○	○
New Web design	The web screen design is renewed for user friendly interface. *1	○ ○ △ ●	○
Initial setting software	The initial setting can be configured without the connection of AE-200E. *1	×	×
Apportionment of power consumption	Apportionment of power consumption can be calculated on AE-200 without TG-2000A. *1	●	□ ○ ●
BACnet® communication	ANSI/ASHRAE 135-2010 (ISO16484-5) is supported and approved by the BTL. *1	○	×

*1. Please contact your local distributor for when the feature is supported.

Remote Controller

Centralised Remote Controller or Expansion Module for AE200

Centralised controller EW-50E



Dual Set Point

Dimensions: 209(W) x 172(H) x 92(D) mm
: 8-1/4(W) x 6-25/32(H) x 3-5/8(D) in.

Main Features

- **Available as the expansion controller for AE-200E**
Connecting three EW-50E units to an AE-200E makes it possible to operate and monitor a maximum of 200 indoor units.
- **Apportioned electricity charge function**
The amount of power consumed by the air conditioners is calculated with the use of AE-200E. The calculated data can be output to the PC via USB memory or LAN, and the charge report can be created with the use of the designated charge calculation tool.
*The apportioned electricity charge function on AE-200E and TG-2000A cannot be used together.
*To use the apportioned electricity charge function on AE-200E, check that the version of TG-2000A is 6.60 or later, even if the apportioned electricity charge function on TG-2000A is not used.
*For other restrictions, refer to the Installation Manual and Instruction Book.

System Structure

System diagram (standard)

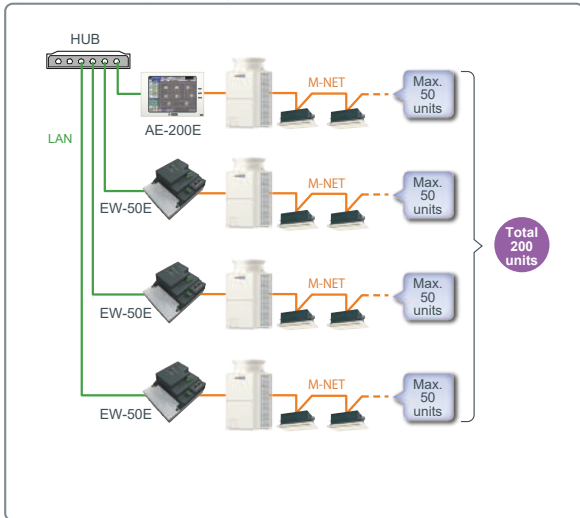

* When M-NET of AE-200E is not used, a maximum of four EW-50E units can be connected.

System diagram (with charge setting)

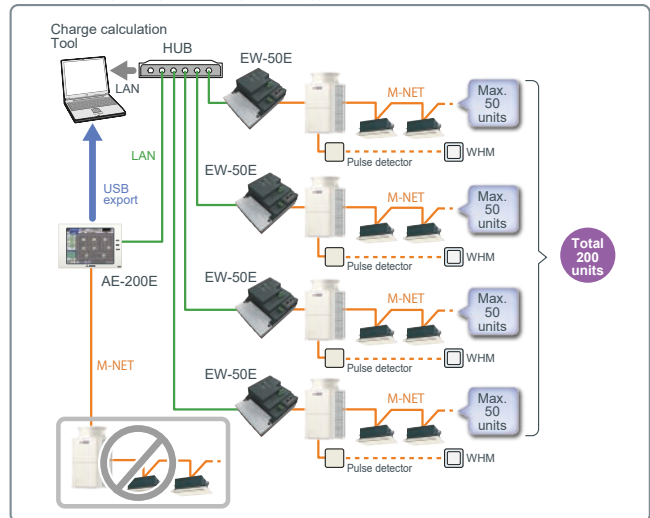

• Enabled to operate and monitor air conditioners independently by using a PC

Even without an AE-200E, EW-50E is possible to monitor and operate air conditioners using a browser software^{*1}. Via the Internet, air conditioners can be monitored and operated from a remote location. In addition, air conditioners in multiple buildings can be operated collectively.^{*2}

* 1. The operation of this product has been confirmed on Internet Explorer 8, IE9, IE10, and IE11, and on Oracle® Java Ver8.

Microsoft® Internet Explorer is a trademark or registered trademark of Microsoft Corporation in the United States and other countries.

Oracle® and Java® are trademarks or registered trademarks of Oracle Corporation, its subsidiaries, and related companies in the United States or other countries.

Company names and product names in this brochure may be trademarks or registered trademarks of the respective rights holder.

- * 2. When connecting an EW-50E via the Internet, do not directly connect the EW-50E to the Internet. Instead, always connect via a router via a VPN function that can ensure security. To monitor the indoor units connected to EW-50E, use TG-2000A of Ver. 6.60 or later.

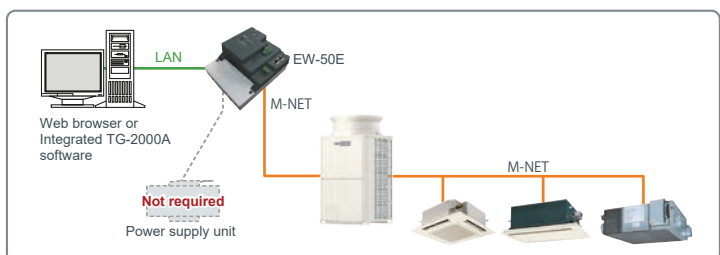

Remote Controller

• **Manage air conditioner usage conditions**

It is possible to use a web browser to display the energy consumption of air conditioners in an easy-to-understand manner.



• **Operable without the transmission line power supply unit**

Because the EW-50E unit is equipped with a power supply function, power supply from a transmission line power supply unit is not necessary.

Since power supply from an outdoor unit is also not necessary, self-sustained operation is possible even when the outdoor unit system goes down. (If the power consumption factor exceeds 1.5, a power supply unit is required.)

• **Energy-saving control**

By adding an energy-saving control license (optional product), the set temperature can be changed automatically¹ based on the room temperature surrounding each air conditioner. Therefore, energy-saving control is possible without affecting comfort greatly.

* 1. This function changes the set temperature in units of +2°C for cooling and -2°C for heating by the specified time interval.

If the difference between the suction temperature and the set temperature is significant, it is possible to exclude it from the energy-saving subject.

Functions

* The functions and specifications are subject to change.

☉ : By group or multiple groups ○ : By group □ : Batch only

Item	Remarks	Setting	Display
ON/OFF	Switches to ON or OFF air conditioners and general equipment.	☉	☉
Operation mode switching	Switches to cool, dry, auto, fan, or heat operation. * Depending on the unit, some modes are not available.	☉	○
Room temperature setting	The temperature can be set within the following range. Cool/Dry: 19°C - 35°C/67°F - 95°F Heat: 4.5°C - 28°C/40°F - 83°F Auto (single set point): 19°C - 28°C/67°F - 83°F Auto (dual set points) [Cool] Same as the set temp. range for Cool mode. [Heat] Same as the set temp. range for Heat mode. * Set temperature range varies depending on the model.	☉	○
Set temperature 0.5°C increments	The temperature can be set and displayed in 0.5°C increments. * With some unit combinations, the temperature is set in 1°C increments.	☉	○
Fan speed setting	The fan speed can be set to 4 levels, 3 levels, 2 levels or automatic. * Available fan speeds differ depending on the unit.	☉	○
Air direction setting	Fixed swing in five levels or auto air direction can be set. * Available air directions differ depending on the unit.	☉	○
Prohibition of local remote controller operation	It is possible to disable the ability to use to local remote controller to run or stop, the operation mode, set temperature, filter sign reset, wind speed, wind direction and timer operation. * In the Lossnay group, only ON/OFF and filter reset can be disabled. * Disabling of the fan speed, air direction, and timer operation can be set for the PAC-SF50AT, PAR-36MA, PAR-F30ME, and PAC-YT52CR models.	☉	○
Room temperature display	Displays the suction temperature of the indoor unit.	—	○
Error display	Displays the current error content together with the address.	—	☉
Schedule operation	Today/weekly/weekly by season/yearly Setting content: ON/OFF, operation mode, set temperature, disable local remote controller, air direction/fan	☉	○
Energy management	Displays the power consumption* or operating hours. * Requires an optional part.	—	☉
Ventilator operation (solo)	Group operation can be possible for free plan Lossnay units only. * The above group operation mode includes auto ventilation, heat exchange, and normal ventilation.	☉	○
Ventilator operation (interlocked)	Free plan Lossnay units and indoor units can be interlocked and operated together. * At this point, air volume can be operated but the ventilation mode cannot be selected.	☉	○
External input (timer connection, emergency stop input, etc.)	Using a level signal or pulse signal, it is possible to input the following. Level signal: Emergency Stop Input, Batch ON/OFF, and Demand Input. Pulse signal: Batch ON/OFF or Operation Disable/Enable * Requires an external power supply and separately sold external I/O adapter (PAC-YG10HA). Of the above inputs, only one input can be selected.	□	—
External output (error output, operation output)	Using the level signal, ON/OFF and Error/Normal are output. *Requires an external power supply and separately sold external I/O adapter (PAC-YG10HA).	—	□
Web browser	Monitor/operation, failure, filter sign monitoring, schedule setting, interlocked control setting (option), energy saving control setting (option), energy saving peak cut setting (option), set temperature range restrictions, other	☉ ⁺¹	☉ ⁺¹
Filter reset	Filter sign reset	○	○
Connectable location	Centralized system transmission line: Connectable Recommended Indoor and outdoor transmission line: Connectable	—	—

* The functions and specifications differ depending on the connected equipment and model.
* Electric energy can be proportionally divided using the EW-50E alone.
But the apportioned electricity charge function requires an AE-200E or TG-2000A.

■Notes
* 1. Some items do not support the multi group setting and display.
* 2. Use only items for which the unit has the function.

- Connectable equipment: Free plan direct expansion system air conditioner
- Inverter air conditioner for facility
- Package air conditioner for facility (the AW control model can be connected using an M control compatible indoor unit)
- A Control Mr. Slim (Can be connected using an M-NET adapter or special outdoor unit)
- Kirigamine room air conditioner (Requires a system control interface or M-NET control interface)
- Free plan Lossnay/Lossnay with heating and humidification
- Independent humidification unit ²
- Environmental measuring controller, metering measurement controller, general interface

System Structure

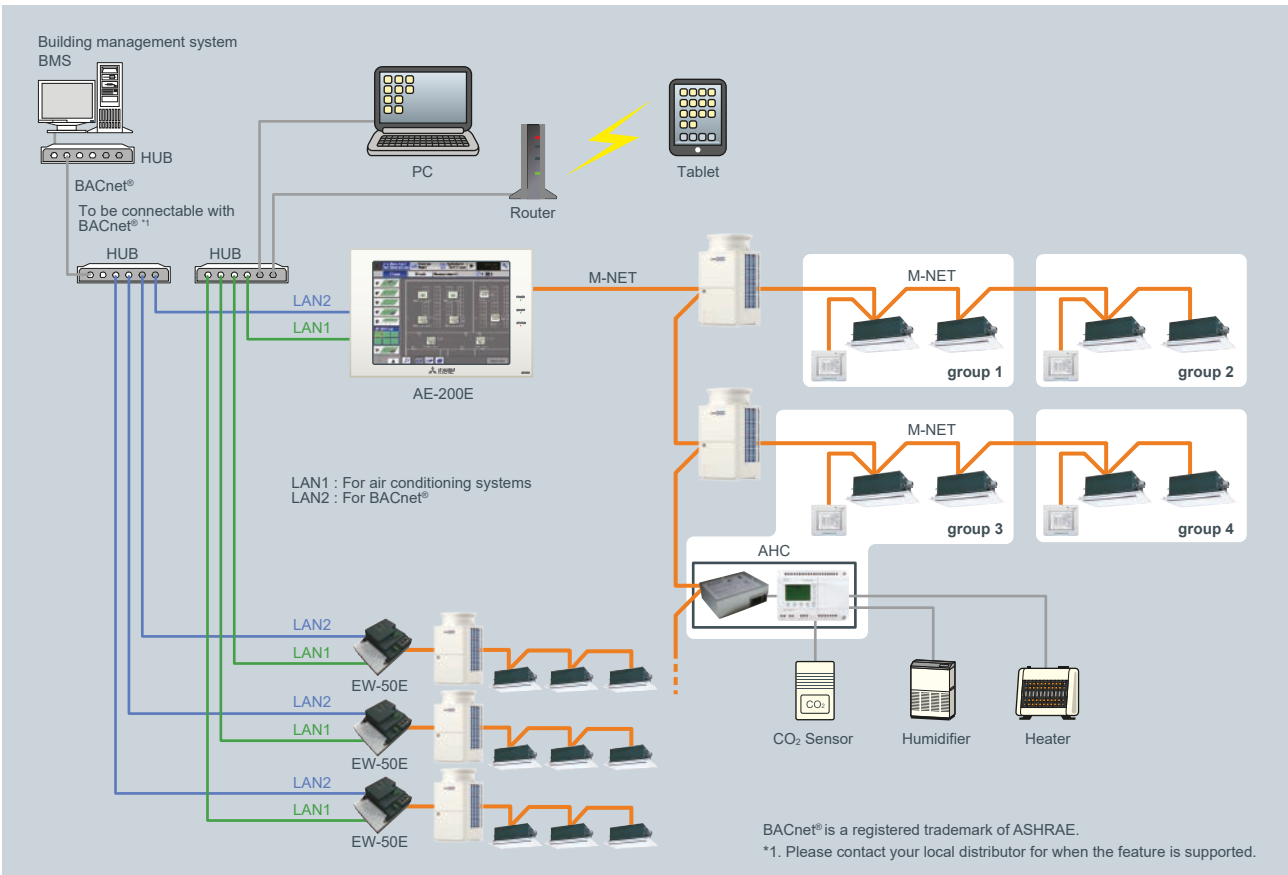

Functions

Item	Description	Operations	Display
Controllable number of unit	Up to 50 units/50 groups		
ON/OFF	ON and OFF operation for the air conditioning units and general equipment. (To operate general equipment, PAC-YG66DCA is required.)	○ ○ △ ●	○ ○
Operation mode	Switches between several operation modes depending on the air conditioning unit. Air conditioning unit : Cool/Dry/Auto(*)/Fan/Heat LOSSNAY unit : Heat Recovery/Bypass/Auto CAHV, CRHV, Air To Water (PWFY) units : Heating, Heating ECO, Hot Water, Anti-freeze, Cooling(**) * Auto mode is for CITY MULTI R2 and WR2 series only. ** Only PWFY	○ ○ △ ●	○
Temperature setting	Cool/Dry : 19°C (67°F) -35°C (95°F) [14°C (57°F) -30°C (87°F)] Heat : 4.5°C (40°F) -28°C (83°F) [17°C (63°F) -28°C (83°F)] Auto : 19°C (67°F) -28°C (83°F) [17°C (63°F) -28°C (83°F)] The range of temperature depends on the air conditioning unit. [] in case of using middle-temperature on PDFY, PEFY-VML/VMR/VMS/VMH-by setting DipSW7-1 to ON. Yet, PEFY-P-VMH-E-F is excluded.	○ ○ △ ●	○
Fan speed setting	Models with 4 air flow speed settings : Hi/Mid-2/Mid-1/Low Models with 3 air flow speed settings : Hi/Mid/Low Models with 2 air flow speed settings : Hi/Low Fan speed setting (including Auto) varies depending on the model.	○ ○ △ ●	○
Air flow direction setting	Air flow direction angles, 4-angles or 5-angles Swing, Auto (Louver cannot be set)	○ ○ △ ●	○
Schedule operation	Weekly schedule can be set by groups based on daily operation pattern.	○ ○ △ ●	○
Permit/prohibit local operation	Individually prohibits operation of each local remote controller function. (ON/OFF, Operation mode, Set temperature, Filter sign reset, Air Direction*, Fan Speed*, Timer*) * This function depends on the model.	○ ○ △ ●	○
Indoor unit intake temperature	Measures the intake temperature of the indoor unit only when the indoor unit is operating.	×	○
Error	When an error is currently occurring on an air conditioning unit, the afflicted unit and the error code are displayed.	×	□ ○
Test run	This operates air conditioning units in test run mode.	○ ○ △ ●	○
Ventilation interlock	The ventilation unit (LOSSNAY) is able to automatically start its operation when operation of the interlocked indoor unit starts.	○ ○ △ ●	○
External input/output	By using optional external input/output adapter (PAC-YG10HA-E) you can set and monitor the following. Input : By level signal : "Batch ON/OFF", "Batch emergency stop" By pulse signal : "Batch ON/OFF", "Enable/disable local remote controller" Output : "ON/OFF", "Error/Normal"	○	○
Energy Management	Bar Graph : Indoor unit Electric Energy, FAN operation time, Thermo-ON time (TOTAL, Cooling, Heating) can be displayed hourly, daily and monthly. Line Graph : Outdoor temp., Room temp., Set temp. (Heating, Cooling) input from PAC-YG63MCA and temp. from AHC.	×	□ ○ ●
Advanced HVAC Controller (AHC)	The status of AHC can only be monitored.	×	○
New Smart ME controller	The status of sensor on this controller can be monitored.	×	○
Smartphone/Tablet	The specified Web browser on iOS and Android OS can monitor and operate AE-200E. *1	○	○
New Web design	The web screen design is renewed for user friendly interface. *1	○ ○ △ ●	○
Initial setting software	The initial setting can be configured without the connection of AE-200E. *1	×	×
Apportionment of power consumption	Apportionment of power consumption can be calculated on AE-200 without TG-2000A. *1	●	□ ○ ●
BACnet® communication	ANSI/ASHRAE 135-2010 (ISO16484-5) is supported and approved by the BTL. *1	○	×

*1. Please contact your local distributor for when the feature is supported.

New Centralised Remote Controller

Flexible management ranging from tenant management to centralized management of small scale buildings

► MAIN FEATURES

Available as the expansion controller for AE-200E

Connecting three EW-50E units to an AE-200E makes it possible to operate and monitor a maximum of 200 indoor units.

Apportioned electricity charge function

The amount of power consumed by the air conditioners is calculated with the use of AE-200E. The calculated data can be output to the PC via USB memory or LAN, and the charge report can be created with the use of the designated charge calculation tool.

*The apportioned electricity charge function on AE-200E and TG-2000A cannot be used together.

*To use the apportioned electricity charge function on AE-200E, check that the version of TG-2000A is 6.60 or later, even if the electricity charge function on TG-2000A is not used.

*For other restrictions, refer to the Installation Manual and Instruction Book.

[System Structure]

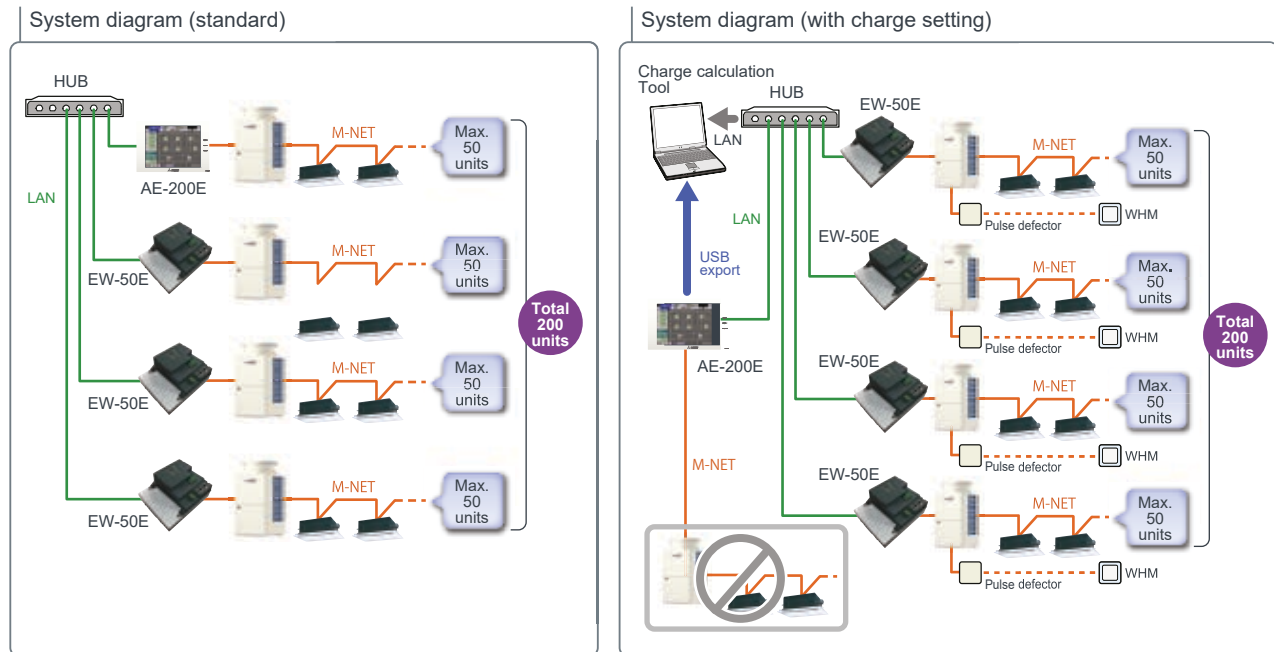

* When M-NET of AE-200E is not used, a maximum of four EW-50E units can be connected.

Enabled to operate and monitor air conditioners independently by using a PC

Even without an AE-200E, EW-50E is possible to monitor and operate air conditioners using a browser software¹. Via the Internet, air conditioners can be monitored and operated from a remote location. In addition, air conditioners in multiple buildings can be operated collectively.²

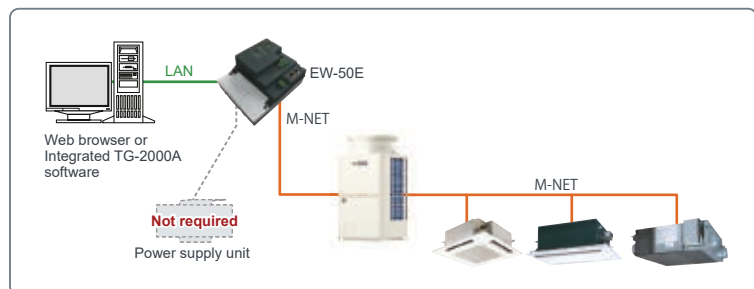

¹ 1. The operation of this product has been confirmed on Internet Explorer 8, IE9, IE10, and IE11, and on Oracle® Java Ver8.

Microsoft® Internet Explorer is a trademark or registered trademark of Microsoft Corporation in the United States and other countries.

Oracle® and Java® are trademarks or registered trademarks of Oracle Corporation, its subsidiaries, and related companies in the United States or other countries.

Company names and product names in this brochure may be trademarks or registered trademarks of the respective rights holder.

² 2. When connecting an EW-50E via the Internet, do not directly connect the EW-50E to the Internet.

Instead, always connect via a router via a VPN function that can ensure security.

To monitor the indoor units connected to EW-50E, use TG-2000A of Ver. 6.60 or later.

Manage air conditioner usage conditions

It is possible to use a web browser to display the energy consumption of air conditioners in an easy-to-understand manner.



Operable without the transmission line power supply unit

Because the EW-50E unit is equipped with a power supply function, power supply from a transmission line power supply unit is not necessary.

Since power supply from an outdoor unit is also not necessary, self-sustained operation is possible even when the outdoor unit system goes down. (If the power consumption factor exceeds 1.5, a power supply unit is required.)

Energy-saving control

By adding an energy-saving control license (optional product), the set temperature can be changed automatically^{*1} based on the room temperature surrounding each air conditioner. Therefore, energy-saving control is possible without affecting comfort greatly.

* 1. This function changes the set temperature in units of +2°C for cooling and -2°C for heating by the specified time interval. If the difference between the suction temperature and the set temperature is significant, it is possible to exclude it from the energy-saving subject.

FUNCTIONS

* The functions and specifications are subject to change.

: By group or multiple groups : By group : Batch only

Item	Remarks	Setting	Display
ON/OFF	Switches to ON or OFF air conditioners and general equipment.	<input type="radio"/>	<input type="radio"/>
Operation mode switching	Switches to cool, dry, auto, fan, or heat operation. * Depending on the unit, some modes are not available.	<input type="radio"/>	<input type="radio"/>
Room temperature setting	The temperature can be set in the following range. The values inside the parenthesis are for indoor units for medium temperature. * Depending on the model, the setting temperature range differs. · Cooling/dry : 19°C to 35°C (4.5°C to 30°C) · Heating : 17°C to 28°C (17°C to 28°C) · Auto : 19°C to 28°C (17°C to 28°C)	<input type="radio"/>	<input type="radio"/>
Set temperature 0.5°C increments	The temperature can be set and displayed in 0.5°C increments. * With some unit combinations, the temperature is set in 1°C increments.	<input type="radio"/>	<input type="radio"/>
Fan speed setting	The fan speed can be set to 4 levels, 3 levels, 2 levels or automatic. * Available fan speeds differ depending on the unit.	<input type="radio"/>	<input type="radio"/>
Air direction setting	Fixed swing in five levels or auto air direction can be set. * Available air directions differ depending on the unit.	<input type="radio"/>	<input type="radio"/>
Prohibition of local remote controller operation	It is possible to disable the ability to use to local remote controller to run or stop, the operation mode, set temperature, filter sign reset, wind speed, wind direction and timer operation. * In the Lossnay group, only ON/OFF and filter reset can be disabled. * Disabling of the fan speed, air direction, and timer operation can be set for the PAC-SF50AT, PAR-36MA, PAR-F30ME, and PAC-YT52CR models.	<input type="radio"/>	<input type="radio"/>
Room temperature display	Displays the suction temperature of the indoor unit.	—	<input type="radio"/>
Error display	Displays the current error content together with the address.	—	<input type="radio"/>
Schedule operation	Today/weekly/weekly by season/yearly Setting content: ON/OFF, operation mode, set temperature, disable local remote controller, air direction/fan	<input type="radio"/>	<input type="radio"/>
Energy management	Displays the power consumption* or operating hours. * Requires an optional part.	—	<input type="radio"/>
Ventilator operation (solo)	Group operation can be possible for free plan Lossnay units only. * The above group operation mode includes auto ventilation, heat exchange, and normal ventilation.	<input type="radio"/>	<input type="radio"/>
Ventilator operation (interlocked)	Free plan Lossnay units and indoor units can be interlocked and operated together. * At this point, air volume can be operated but the ventilation mode cannot be selected.	<input type="radio"/>	<input type="radio"/>
External input (timer connection, emergency stop input, etc.)	Using a level signal or pulse signal, it is possible to input the following. Level signal: Emergency Stop Input, Batch ON/OFF, and Demand Input. Pulse signal: Batch ON/OFF or Operation Disable/Enable * Requires an external power supply and separately sold external I/O adapter (PAC-YG10HA). Of the above inputs, only one input can be selected.	<input type="checkbox"/>	—
External output (error output, operation output)	Using the level signal, ON/OFF and Error/Normal are output. *Requires an external power supply and separately sold external I/O adapter (PAC-YG10HA).	—	<input type="checkbox"/>
Web browser	Monitor/operation, failure, filter sign monitoring, schedule setting, interlocked control setting (option), energy saving control setting (option), energy saving peak cut setting (option), set temperature range restrictions, other	<input type="radio"/> * ₁	<input type="radio"/> * ₁
Filter reset	Filter sign reset	<input type="radio"/>	<input type="radio"/>
Connectable location	Centralized system transmission line: Connectable Recommended Indoor and outdoor transmission line: Connectable	—	—

* The functions and specifications differ depending on the connected equipment and model.

* Electric energy can be proportionally divided using the EW-50E alone.
But the apportioned electricity charge function requires an AE-200E or TG-2000A.

■Connectable equipment: Free plan direct expansion system air conditioner
Inverter air conditioner for facility
Package air conditioner for facility (the AW control model can be connected using an M control compatible indoor unit)
A Control Mr. Slim (Can be connected using an M-NET adapter or special outdoor unit)
Kirigamine room air conditioner (Requires a system control interface or M-NET control interface)
Free plan Lossnay/Lossnay with heating and humidification
Independent humidification unit²
Environmental measuring controller, metering measurement controller, general interface

■Notes

* 1. Some items do not support the multi group setting and display.

* 2. Use only items for which the unit has the function.

SPECIFICATIONS

Item	Description	
No. of indoor units that can be connected and controlled	Up to 50 units ¹ per EW-50E	
Monitoring/operation	Web-based monitoring and operation, or monitoring and operation through the AE-200E LCD display	
Product dimensions	209 mm (H) × 172 mm (W) × 92 mm (D)	
Power supply	AC100 to AC240V (50/60Hz)	
Power feeding coefficient	1.5	
Communication I/F	Power supply from the main unit (power supply switching connector: CN40) M-NET/LAN (100BASE-TX)	
Operating environment	Temperature	-10 to 55°C
	Humidity	30 to 90% RH (Non-condensing)
Installation conditions	Only in a metal control box Note: For indoor installation only ²	
Housing material	Electro-galvanized steel sheet	
Applicable wire size	Power supply, ground	Recommended type: VCT, VVF, VVR or its equivalent Wire size: 2mm ² or more (Ø1.6mm or more)
	M-NET	2-core cable with shielded wire CPEVS: Ø1.2mm to Ø1.6mm CVVS: 1.25mm ² to 2mm ²

*1. Depending on the indoor unit model used, the maximum number of units that can be managed may be less. If the DIDO controller (PAC-YG66DCA) is used, the number of units is less due to the number of channels provided. (1ch corresponds to one managed unit.)

*2. The product should be used in a business office environment, or the equivalent.

EXTERNAL DIMENSIONS

■ When using L-fittings

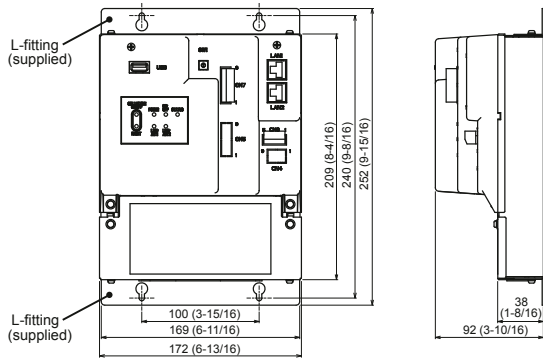

■ When using DIN rail

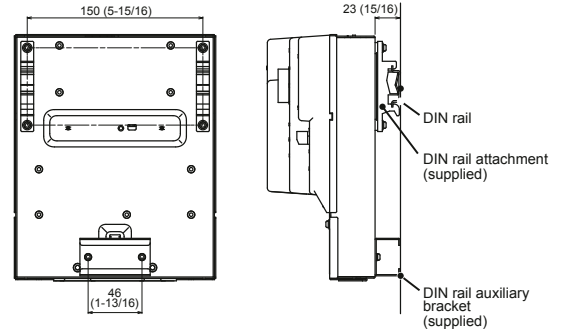

Remote ON/OFF Group Control

Just press a switch to start. All of the units can be switched On/Off by pressing the On/Off button, and each unit in the group can be turned On/Off with an individual button. The PAC-YT40ANRA also has a hardwired connection available (On/Off input, fire alarm input, run output, fault output).

ON/OFF remote controller PAC-YT40ANRA

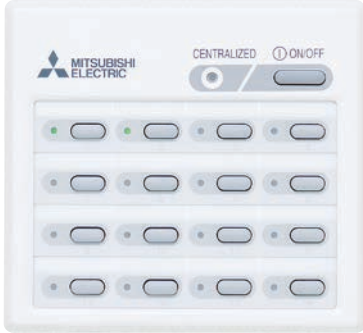

- The group setting is kept in nonvolatile memory. No need to worry about re-setting after a power failure
- No individual AC power supply is needed
The power can be supplied from one outdoor unit (R410A) or Power supply unit

Dimensions: 130(W) x 120(H) x 19(D) mm
: 5-1/8(W) x 4-23/32(H) x 3/4(D) in.

System example

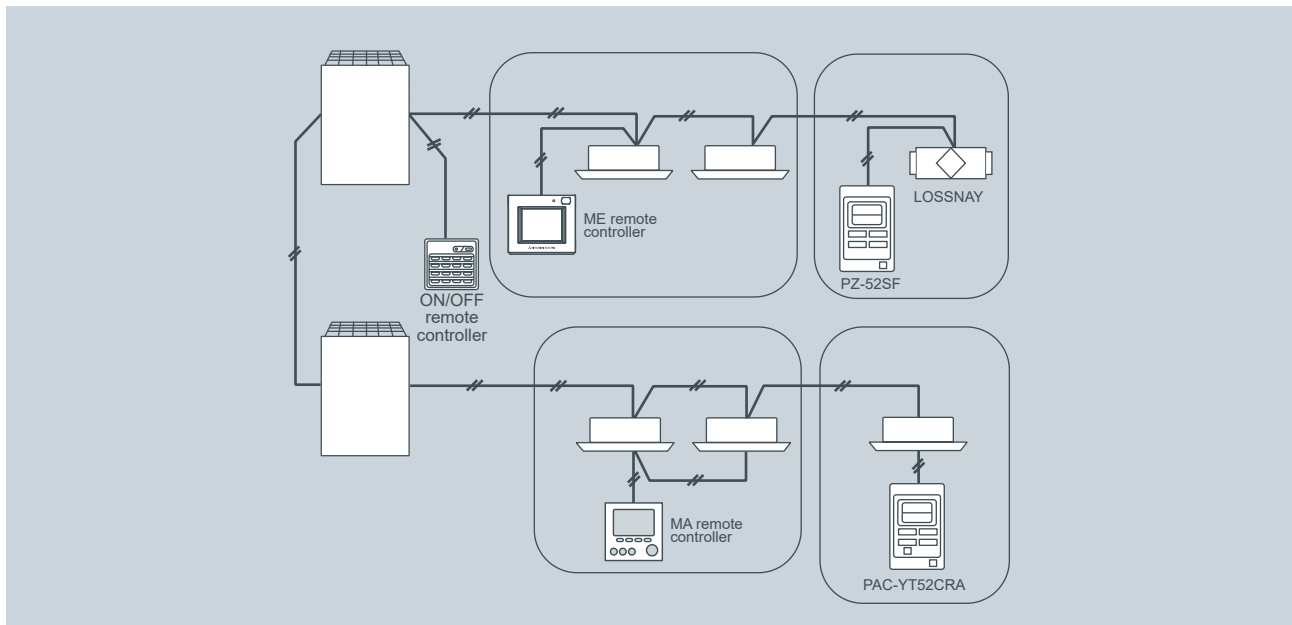

FUNCTION	DESCRIPTION	PAC-YT40ANRA	
UNITS	Max No.Units	50 units/16 groups	
		OPERATIONS	DISPLAY
ON/OFF	Run and stop operation	✓	✓
ERROR INDICATION	LED flashes during failure. (The error code can be confirmed by removing the cover.)	-	✓
VENTILATION OPERATION (INDEPENDENT)	Group operation of only LOSSNAY units possible. *Only ON/OFF of group.	✓	✓
VENTILATION OPERATION (INTERLOCKED)	The LOSSNAY will run in interlock with the operation of indoor unit. *The fan rate and mode cannot be changed. The LED will turn ON only during operation after interlocking.	✓	✓
EXTERNAL INPUT	On/Off/Fire Alarm *	✓	-
EXTERNAL OUTPUT	On/Off/Faults *	-	✓

* Applicable to collective only
Not applicable to groups

Remote Controller

Advanced HVAC Controller

PAC-IF01AHC-J + PLC



Dimensions: 116(W) x 90(H) x 40(D) mm
: 4-9/16(W) x 3-1/2(H) x 1-9/16(D) in.

Advanced HVAC Controller (hereafter referred to as AHC) comprises of Mitsubishi Electric's AHC Adapter (PAC-IF01AHC-J) and $\alpha 2$ Simple Application Controller* (hereafter referred to as ALPHA2).

* $\alpha 2$ Simple Application Controller is one of the Programming Logic Controllers that are manufactured by Mitsubishi Electric Corporation.

AHC allows for the connection of Mitsubishi Electric's air conditioning network system (hereafter referred to as M-NET) to other systems, which was not possible with the use of ALPHA2 alone. AHC provides the following functions.

- ① Controls external devices using the sensor data of the air conditioning units connected to M-NET.
- ② Interlocks the operation of air conditioning units and external devices that are connected to ALPHA2.
- ③ Controls air conditioning units that are connected to M-NET.
- ④ Allows for the combined use of the items ①-③ above.
- ⑤ Monitors the input/output status of ALPHA2 via a remote controller or a centralised controller.

* Refer to the manual that came with ALPHA2 for information about ALPHA2.

* The use of AHC ADAPTER requires either a remote controller or a centralised controller.

System Structure

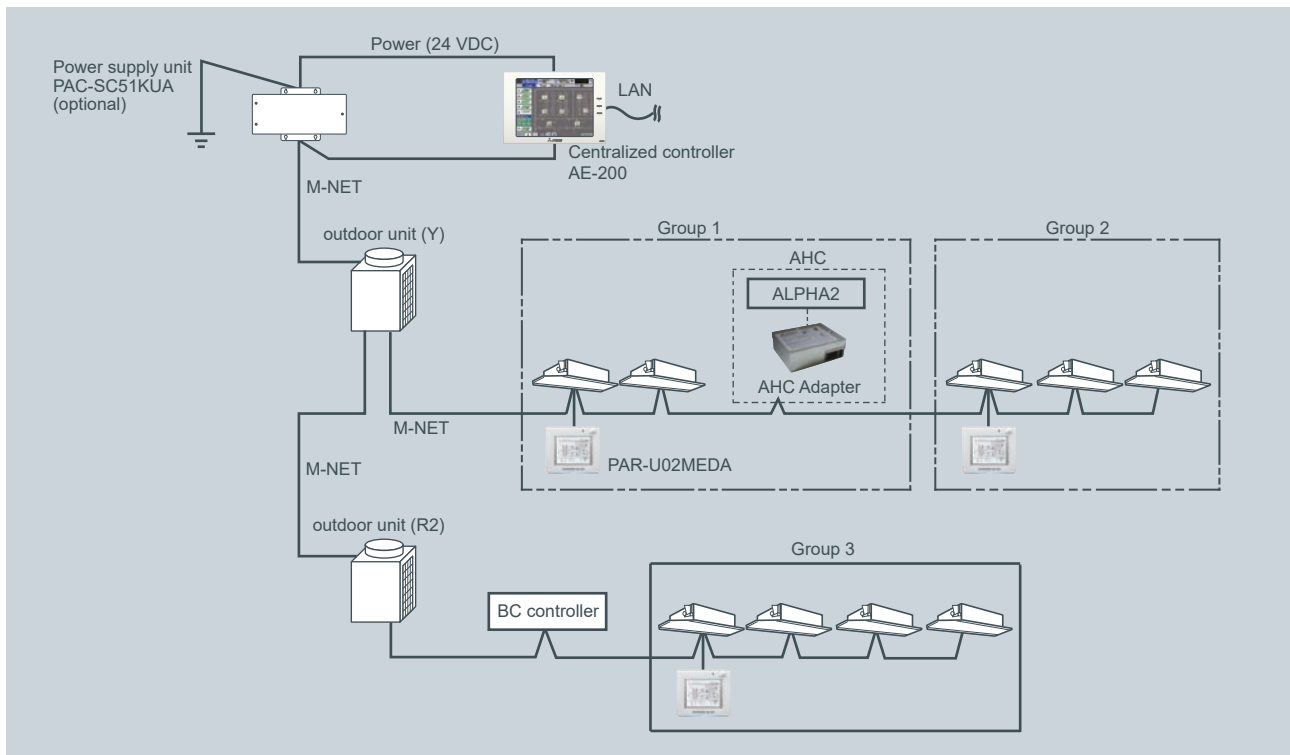

Remote Controller

Energy Monitoring Control

PI Controller PAC-YG60MCA



Dimension: 200(W) x 120(H) x 45(D) mm
: 7-7/8(W) x 4-3/4(H) x 1-13/16(D) in.

No more PLCs are needed!

Our new PI controller makes it possible to perform energy saving without PLC, which is cost saving. Maximum of 4 measurement meter (WHM, gas meter, water meter, calorie meter) can be connected to the PI controller and can be used also for charge calculation.

*24 VDC power needs to be provided on site.

Energy Saving Control (Peak Cut)

Enables Energy Saving Control with the use of our new PI controller. (Registration of "Energy Management license pack" is required.)

To perform energy saving, the capacity of the outdoor unit is controlled.

*Please note that when using an energy saving control, there are no warranties to failures such as usage over the contracted electricity.

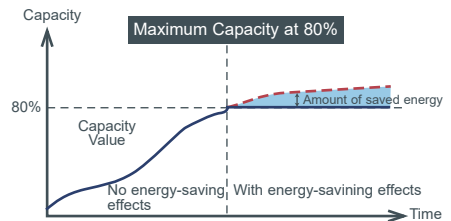

System Structure

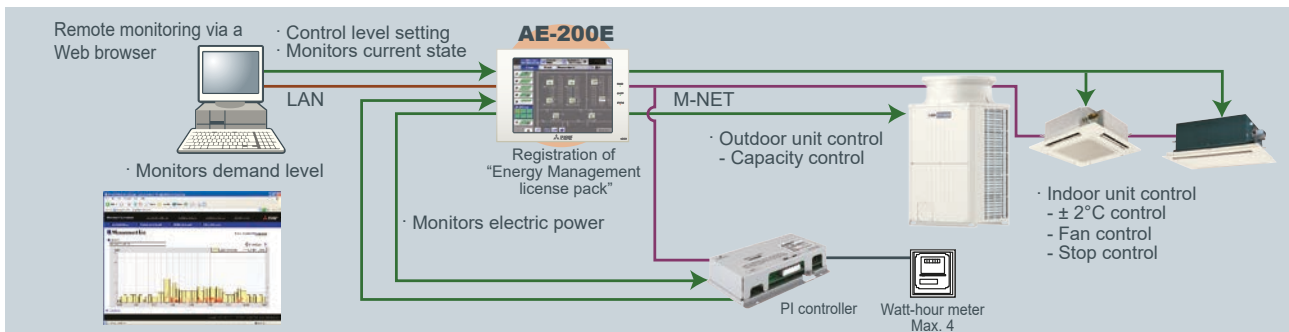

Charge Calculation

Enables charge calculation for each tenant and output as CSV file

System Structure

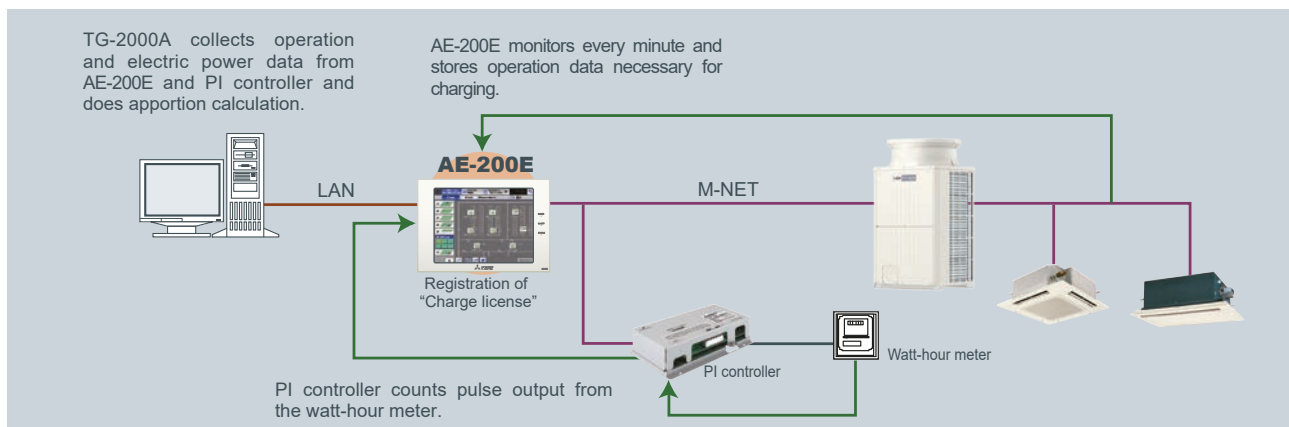

General Equipment Control

DIDO Controller PAC-YG66DCA



Dimension: 200(W) x 120(H) x 45(D) mm
: 7-7/8(W) x 4-3/4(H) x 1-13/16(D) in.

No more PLCs are needed!

Our new DIDO controller makes it possible to control general-purpose equipment without PLC, saving costs. Up to 6 general-purpose equipment can be connected to the DIDO controller.

*24 VDC power needs to be provided on site.

General-purpose equipment control

Enables control and monitoring of equipment other than air conditioners (air conditioners of other companies, lights, ventilators, etc.)

System Structure

- In addition to above, the air conditioners can be interlocked with general-purpose equipment
E.g. Interlock between indoor units and security system
- The indoor units can be turned ON/OFF when the security system is activated/deactivated

Icon display (Lights)

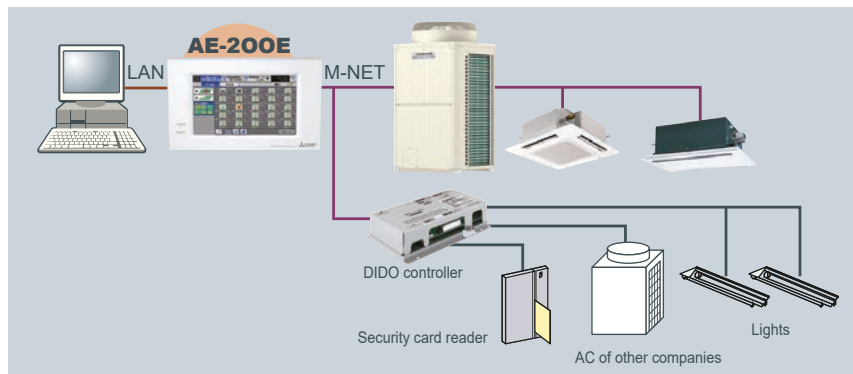

AI Controller PAC-YG63MCA



Dimension: 200(W) x 120(H) x 45(D) mm
: 7-7/8(W) x 4-3/4(H) x 1-13/16(D) in.

Our new AI controller makes it possible to monitor the values measured by the temperature/humidity sensor connected to the AI controller.

The AI controller has two input and two output channels.

*24 VDC power needs to be provided on site.

Temperature/Humidity Monitoring

Monitors the values measured by the temperature/humidity sensor connected to the AI controller

Temperature : Pt100, 4 to 20mA DC, 1 to 5 VDC, 0 to 10 VDC
Humidity : 4 to 20mA DC, 1 to 5 VDC, 0 to 10 VDC

- Trend displays of measurement data can be shown on a Web browser
- An alarm can be output by e-mail when measurement data exceeds a preset upper or lower limit

System Structure

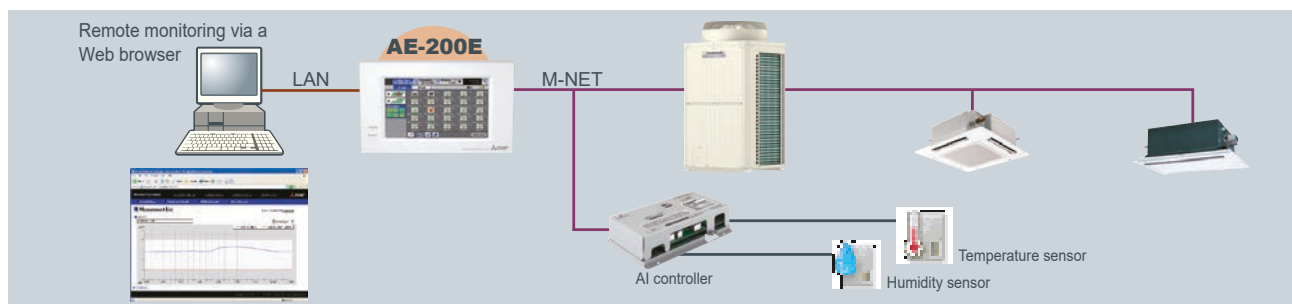

Remote Controller

TG-2000 Computer

Integrated centralised control software TG-2000A

Example of Basic System Configuration

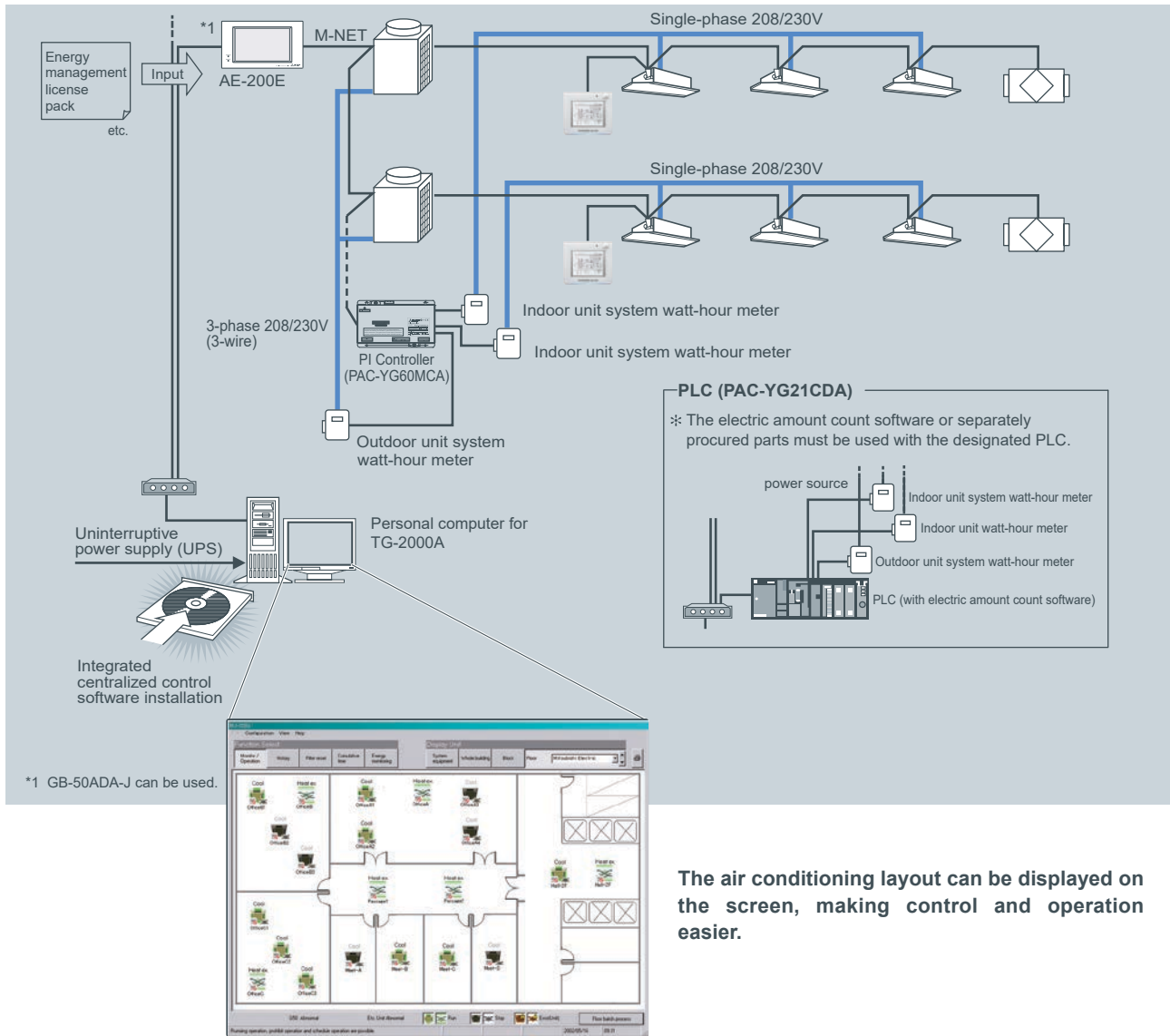

Effective use of TG-2000A

Multiple air conditioning charges in multiple buildings can be calculated. The power apportionment percentage data and apportioned power rate can be calculated for each unit, and can be output as a CSV file.



For example, installing TG-2000A to the system in the headquarters makes it possible to control AG-150A/GB-50ADA-J units that are used in branch offices.



BMS Interface Modules

LONWORKS® (LMAP04)

CITY MULTI can easily combine into a Building Management System (BMS) via the LONWORKS® and M-NET adapter LMAP04. LONWORKS® is an opened transmission protocol widely used at BMS, and related equipment control. CITY MULTI is therefore compatible with large-scaled BMS management via LONWORKS®.

One LM ADAPTER unit can connect up to 50 Groups/50 indoor units.

Using a single LONWORKS® adapter (LM-AP), you can connect up to a maximum of 50 indoor units.

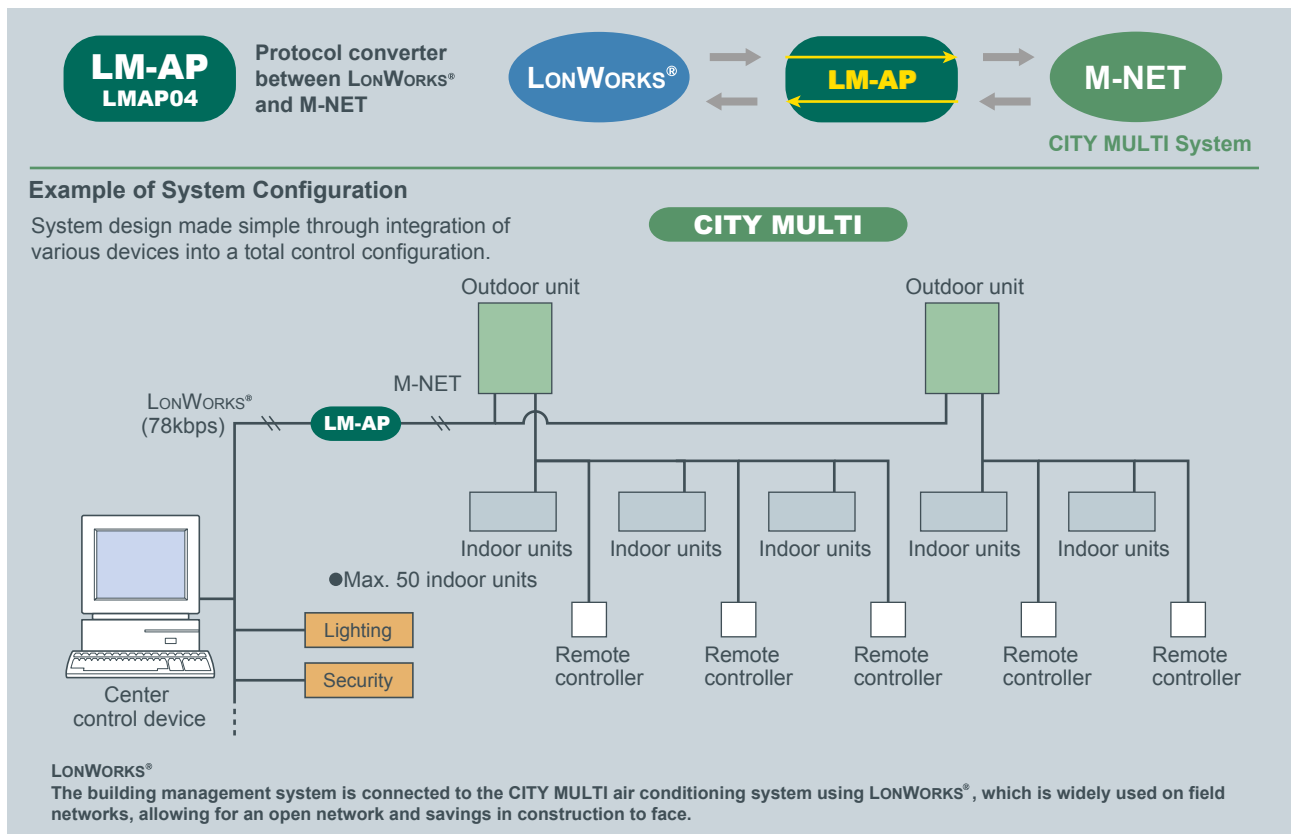

LON, LONWORKS® and the Echelon logo are trademarks of Echelon Corporation registered in the United States and other countries.

LONWORKS® INTERFACE

FUNCTION	CONTENT
Control	
ON/OFF	Run/Stop
Mode Operation	Cooling/Drying/Heating/Auto/Fan/Setback
Setpoint Adjustment	Cooling 19-35°C, Heating 4.5-28°C, Auto 19-28°C
Fan Speed Control	Lo-Mi1-Mi2-Hi
Permit/Prohibit	ON/OFF, Mode, Setpoint
Emergency Stop	-
Monitoring	
ON/OFF	Run/Stop
Mode	Cooling/Drying/Heating/Auto/Fan/Setback
Setpoint	Cooling 19-35°C, Heating 4.5-28°C, Auto 19-28°C
Fan Speed	Lo-Mi1-Mi2-Hi
Permit/Prohibit	ON/OFF, Mode, Setpoint
Alarm State	Normal/Abnormal
Room Temperature	-10°C~50°C
Thermo ON/OFF	ON/OFF



Remote Controller

BACnet® (BAC-HD150)

CITY MULTI can easily combine into a Building Management System (BMS) via the BACnet® and M-NET adapter BAC-HD150. BACnet® is an opened transmission protocol widely used at BMS, and related equipment control. CITY MULTI is therefore compatible with large-scaled BMS management via BACnet®.

BAC-HD150 can control up to 50 units/groups (including LOSSNAY).

Up to 150 units/groups (including LOSSNAY) can be controlled from one BAC-HD150 with three expansion controllers. (50 units/EW-50)

When the dual-set-point function is used, no expansion controllers can be connected, and only up to 50 units/groups can be controlled from each BAC-HD150.

System example (Connection of 150 units / groups with EW-50)

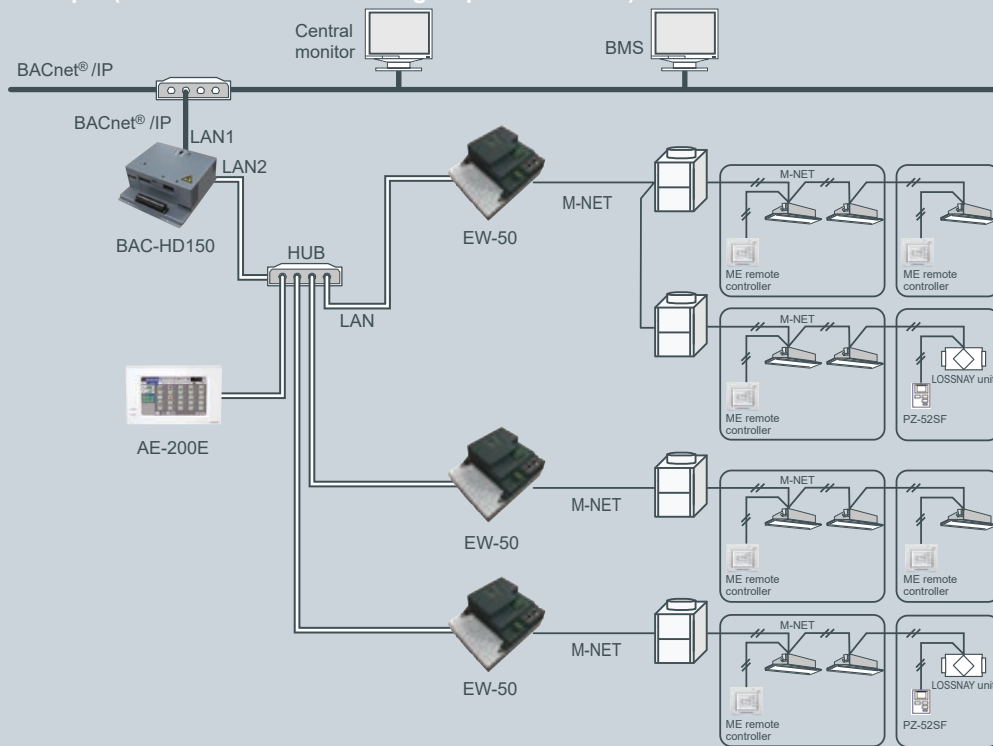

BACnet® and M-NET adapter

FUNCTION	CONTENT
Operation	
ON/OFF	Run/Stop
Mode	Cool/Dry/Heat/Auto/Fan/Setback
Fan Speed	Low-Mid1-Mid2-Hi
Airflow Direction	Horizontal- 60°-80°-100°swing
Set Temperature	Cooling 19-35°C [67-95°F], Heating 4.5-28°C [40-83°F], Auto 19-28°C [67-83°F]
Filter Sign Reset	Normal/Reset
Permit/Prohibit	ON/OFF, Mode, Filter sign reset, Set temp.
Forced OFF	Release/Effective
Monitoring	
ON/OFF	Run/Stop
Mode	Cool/Dry/Heat/Fan/Setback
Fan Speed	Low-Mid1-Mid2-Hi
Air Direction	Horizontal- 60°-80°-100°swing
Set Temperature	Cooling 19-35°C [67-95°F], Heating 4.5-28°C [40-83°F], Auto 19-28°C [67-83°F]
Filter Sign	Normal/Reset
Permit/Prohibit	ON/OFF, Mode, Filter sign reset, Set temp.
Indoor Temperature	-
Alarm Signal	Normal/Abnormal
Error Code	2 Character code- Indicates all unit alarms
Communication State	Normal/Abnormal



Optional Parts



Optional Parts

OPTIONAL PARTS FOR INDOOR UNITS

>>4-way cassette type (PLFY-VBM/VFM)

Description	Model	Applicable capacity	
		VBM	VFM
Decoration panel	SLP-2FA (L) (E)	–	P15, P20, P25, P32, P40, P50
Automatic Filter Elevation Panel	PLP-6BA	P20, P25, P32, P40, P50, P63, P80, P100, P125	–
Multi-functional casement	PAC-SH63TM-E	P20, P25, P32, P40, P50, P63, P80, P100, P125	–
High-efficiency filter element	PAC-SH59KF-E	P20, P25, P32, P40, P50, P63, P80, P100, P125	–
Wireless signal receiver	PAR-SA9FA-E	P20, P25, P32, P40, P50, P63, P80, P100, P125	–
	PAR-SF9FA-E	–	P15, P20, P25, P32, P40, P50
Space panel	PAC-SH48AS-E	P20, P25, P32, P40, P50, P63, P80, P100, P125	–
"i-see" sensor corner panel	PAC-SA1ME-E	P20, P25, P32, P40, P50, P63, P80, P100, P125	–
	PAC-SF1ME-E	–	P15, P20, P25, P32, P40, P50
Duct flange for fresh air intake	PAC-SH65OF-E	P20, P25, P32, P40, P50, P63, P80, P100, P125	–
Shutter plate	PAC-SH51SP-E	P20, P25, P32, P40, P50, P63, P80, P100, P125	–

>>2-way cassette type (PLFY-VLMD)

Description	Model	Applicable capacity
Decoration panel	CMP-40VLW-C	P20, P25, P32, P40
	CMP-63VLW-C	P50, P63
	CMP-100VLW-C	P80, P100
	CMP-125VLW-C	P125
OA duct flange	PAC-KH11OF	P20, P25, P32, P40, P50, P63, P80, P100

>>1-way cassette type(PMFY-VBM)

Description	Model	Applicable capacity
Decoration panel	PMP-40BM	P20, P25, P32, P40

>>Ceiling concealed type (PEFY-VMH(S))

Description	Model	Applicable capacity	Remarks
Drain pump	PAC-KE04DM-F	P40~P250	Necessary when long life filter is used
	PAC-KE05DM-F	P200, P250	
Long life filter	PAC-KE86LAF	P40, P50, P63	
	PAC-KE88LAF	P71, P80	
	PAC-KE89LAF	P100, P125, P140	
	PAC-KE85LAF	P200, P250	
Filter box	PAC-KE63TB-F	P40, P50, P63	
	PAC-KE80TB-F	P71, P80	
	PAC-KE140TB-F	P100, P125, P140	
	PAC-KE250TB-F	P200, P250	

>>Ceiling concealed type (PEFY-VMA(L))

Description	Model	Applicable capacity
Filter box	PAC-KE91TB-E	P20, P25, P32
	PAC-KE92TB-E	P40, P50
	PAC-KE93TB-E	P63, P71, P80
	PAC-KE94TB-E	P100, P125
	PAC-KE95TB-E	P140

>>Fresh air intake type (PEFY-VMH-E-F)

Description	Model	Applicable capacity
Long life filter	PAC-KE88LAF	P80
	PAC-KE89LAF	P140
	PAC-KE85LAF	P200, P250
Filter box	PAC-KE80TB-F	P80
	PAC-KE140TB-F	P140
Drain pump	PAC-KE250TB-F	P200/P250
	PAC-KE04DM-F	P80, P140, P200, P250

>>Ceiling suspended type (PCFY-VKM)

Description	Model	Applicable capacity
Drain pump kit	PAC-SH83DM-E	P40
	PAC-SH84DM-E	P63, 100, 125
High efficiency filter	PAC-SH88KF-E	P40
	PAC-SH89KF-E	P63
	PAC-SH90KF-E	P100, 125
Wireless remote controller kit	PAR-SL94B-E	P40, 63, 100, 125

>>Ceiling concealed type (PEFY-VMS1(L))

Description	Model	Applicable capacity	
Drain pump	PAC-KE07DM-E	P15, 20, 25, 32, 40, 50, 63	*For PEFY-VMS1L only
Control box replace kit	PAC-KE70HS-E	P15, 20, 25, 32, 40, 50, 63	

>>Wall mounted type (PKFY-VBM/VHM/VKM)

Description	Model	Applicable capacity
External LEV Box	PAC-SG95LE-E	P15, 20, 25, 32, 40, 50, 63
Drain pump kit	PAC-SH75DM-E	P32, 40, 50
	PAC-SH94DM-E	P63, 100



OPTIONAL PARTS FOR OUTDOOR UNITS

>>For PUMY series

Description	Model
Branch Pipe (2 Branch)	CMY-Y62-G-E
Header	CMY-Y64-G-E
Header	CMY-Y68-G-E
Drain Socket	PAC-SG61DS-E
Centralized Drain Pan	PAC-SH97DP-E
Port Connector (ø9.52 → ø12.7)	PAC-SG73RJ-E
Port Connector (ø15.88 → ø19.05)	PAC-SG75RJ-E
Air Protect Guide (2 pcs required)	PAC-SH95AG-E
Air Outlet Guide	PAC-SH96SG-E

>>For PUHY series

Description	Model	Remarks
Twinning kit	CMY-Y100VBK3	For PUHY-P400-P650YSKB / EP500-EP600YSLM
	CMY-Y200VBK2	For PUHY-P700-P900YSKB
	CMY-Y300VBK3	For PUHY-P950-P1350YSKB / EP650-EP1350YSLM
Branch pipe (Joint)	CMY-Y102SS-G2	200 or below (Total capacity of indoor unit)
	CMY-Y102LS-G2	201-400 (Total capacity of indoor unit)
	CMY-Y202S-G2	401-650 (Total capacity of indoor unit)
	CMY-Y302S-G2	The 1st branch of P400-P650YSKB / EP400-EP600YSLM 651 or above (Total capacity of indoor unit)
Branch pipe (Header)	CMY-Y104-G	For 4 branches
	CMY-Y108-G	For 8 branches
	CMY-Y1010-G	For 10 branches
Relay box	PAC-BH02KTY-E	Relay box should be used together with Base heater PAC-BH-EHT-E.
Base heater	PAC-BH04EHT-E	For S Module
	PAC-BH05EHT-E	For L Module
	PAC-BH06EHT-E	For XL Module

Note : Indoor unit capacities: the capacity of an indoor unit is the same as the number used for its type identification.

>>For PURY series

Description	Model	Remarks
Twinning kit	CMY-R100VBK-A	For PURY-P400-P500YSLM
	CMY-R100VBK2	For PURY-P550-P650YSLM
	CMY-ER100VBK-A	For PURY-EP500YSLM
	CMY-R200VBK2	For PURY-P700-P800YSLM
	CMY-ER200VBK	For PURY-EP550-EP900YSLM
	CMY-R200XLVBK	For PURY-P850-900YSLM
Branch pipe (Joint)	CMY-Y102SS-G2	200 or below (Total capacity of indoor unit)
	CMY-Y102LS-G2	201-400 (Total capacity of indoor unit)
	CMY-Y202S-G2	401-650 (Total capacity of indoor unit)
Relay box	PAC-BH02KTY-E	Relay box should be used together with Base heater PAC-BH-EHT-E.
	PAC-BH04EHT-E	For S Module
Base heater	PAC-BH05EHT-E	For L Module
	PAC-BH06EHT-E	For XL Module

Note : Indoor unit capacities: the capacity of an indoor unit is the same as the number used for its type identification.

>>For PQHY series

Description	Model	Remarks
Branch pipe (Joint)	CMY-Y102SS-G2	200 or below (Total capacity of indoor unit)
	CMY-Y102LS-G2	201-400 (Total capacity of indoor unit)
	CMY-Y202S-G2	401-650 (Total capacity of indoor unit)
	CMY-Y302S-G2	The first branch of P450-P650 651 or above (Total capacity of indoor unit)
Branch pipe (Header)	CMY-Y104C-G	For 4 branches
	CMY-Y108C-G	For 8 branches
	CMY-Y1010C-G	For 10 branches
Twinning kit	CMY-Y100VBK3	For PQHY-P400-P600YSLM-A
	CMY-Y200VBK2	For PQHY-P700-P900YSLM-A

>>For PQR series

Description	Model	Remarks
Branch pipe (Joint)	CMY-Y102SS-G2	200 or below (Total capacity of indoor unit)
	CMY-Y102LS-G2	201-400 (Total capacity of indoor unit)
Twinning kit	CMY-Q100CBK2	For PQR-P400-P600YSLM-A
	CMY-Q200CBK	For PQR-P700-P900YSLM-A

OPTIONAL PARTS FOR CONTROL

Model	Description	Model	Description
PAC-SE41TS-E	Remote Sensor for A/J/K/M-Net Control	PAC-YG50ECA	Expansion controller for AG-150A
PAC-SE55RA-E	Remote ON/OFF adaptor for Indoor Unit	PAC-SC51KUA	Power supply unit for AG-150A
PAC-SA88HA-EP	Remote Display Adaptor for Indoor Unit	PAC-YG81TB	Mounting attachment B type for AG-150A wall-mount installations
PAC-SA89TA-EP	Timer Adaptor for remote controller	PAC-YG82TB	Mounting attachment for AE-200E wall-mount installations
PAC-SC37SA-E	Output signal connector	PAC-YG83UTB	Electric box for AG-150A wall-embed installations
PAC-SC36NA-E	Input signal connector	PAC-YG84UTB	Electrical box for AE-200E wall-embed installations
PAC-SF46EPA	Transmission booster	PAC-YG85KTB	Mounting attachment A type for AG-150A/PAC-SC51KUA wall-mount installations
LMAP04-E	Air conditioner interface	PAC-YG86TK	Mounting kit for AE-200E wall-mount installations
PAC-YG11CDA	Electric amount count software	PAC-YG71CBL	Black surface cover for AG-150A
BAC-HD150	BAC net® and M-NET adapter	PAC-YG72CWL	Surface cover with USB port for AE-200E
PAC-YT51HAA-J	External input/output adapter for AT-50B		
PAC-YG10HA	External input/output adapter for AE-200E / AG-150A		

OPTIONAL EQUIPMENT FOR BC CONTROLLER

BC Controller Model	Junction pipe kit	Branch pipe
CMB-P104V-G1, GB1	CMY-R160-J1	CMY-Y102SS-G2
CMB-P105V-G1		
CMB-P106V-G1		
CMB-P108V-G1, GA1, GB1		
CMB-P1010V-G1, GA1		
CMB-P1013V-G1, GA1		
CMB-P1016V-G1, GA1, HA1, HB1		



Installation Information

1. General Precautions

1-1. Usage

- The air conditioning systems described in this catalogue are designed and intended for human comfort, and are not designed for the preservation of food, animals, plants, precision equipment or art objects. Do not use the product for any purpose other than what it is designed for.
- Due to the risks associated with water leakage and electric shock, do not use the product for air conditioning vessels or vehicles.

1-2. Installation Environment

- Do not install the unit in an environment where the voltage fluctuates, or in commercial kitchen areas where large amounts of mineral oil (e.g. cutting oil) are present, or large amounts of steam are produced.
- Do not install the unit in an acidic or alkaline environment.
- Do not install the unit in locations which are exposed to chlorine or other corrosive gases. Avoid installation near sewers.
- To reduce the risk of fire, do not install the unit in a place where flammable gas may be leaked or inflammable material is present.
- This air conditioning unit has a built-in microcomputer, which must be considered when choosing the installation position as the unit may interfere with antenna or other electronic devices in the immediate area. It is recommended that the unit should be installed at a distance from these devices.
- The unit should be installed on a solid foundation according to local safety measures associated with extreme weather, wind gusts and earthquakes to prevent the unit from tipping or falling and incurring damage.

1-3. Backup System

- For air conditioning installations where a malfunction could exert critical influence, it is recommended that two or more systems of single outdoor with multiple indoor units are used as backup.

1-4. Unit Characteristics

- In areas where the outdoor temperature is low and the humidity is high, the heat exchanger on the outdoor unit will tend to collect frost, which can affect heating performance. To remove the frost, Auto-defrost function will be activated which will temporarily stop the heating mode for up to several minutes. Heating mode will automatically resume upon completion of the defrost process.
- Heat pump air conditioners require time to warm an entire room immediately after heating operation begins, requiring the indoor unit to circulate warm air to the entire space.
- The sound levels referred to in this catalogue were obtained from test results performed in an anechoic room. The sound levels during actual operation may vary from the simulated results due to ambient noise and acoustic characteristics of the room. Refer to the section "Sound Levels" in the Data Book for the actual measurement location.
- Depending on operating conditions, the unit can generate noise caused by valve actuation, refrigerant flow, and pressure changes during normal operation. It is not recommended that a BC controller is installed in locations where quietness is required (such as bedrooms).
- The total capacity of the connected indoor units can be greater than the capacity of the outdoor unit. However, when the indoor units operate simultaneously, each unit's capacity may be reduced below the rated capacity.
- When the unit is started up for the first time within 12 hours after power on or after power failure, it will perform an initial start-up operation (capacity control operation) to prevent damage to the compressor. The initial start-up operation requires 90 minutes maximum to complete, depending on the operation load.

1-5. Relevant Equipment

- Use an earth leakage breaker (ELB) with medium sensitivity, and an activation speed of 0.1 seconds or less.
- Consult your local distributor or a qualified technician when installing an earth leakage breaker.
- Inverter air conditioners and heat pump units require an earth leakage breaker suitable for handling high harmonic waves and surges.
- Leakage current is generated not only through the air conditioning unit but also through the power wires. Therefore, the leakage current of the main power supply is greater than the total leakage current of each unit. Take into consideration the capacity of the earth leakage breaker or leakage alarm when installing one at the main power supply. To accurately measure the leakage current on site, use a measurement tool equipped with a filter, and clamp all four power wires together. The leakage current measure on the ground wire may not be accurate due to the leakage current from other systems being included in the measurement value.
- Do not install a phase advancing capacitor on a unit which is connected to the same power system as an inverter type unit and its equipment.
- If a large current is produced by either a product malfunction or faulty wiring, both the earth leakage breaker on the product as well as the upstream overcurrent breaker may trip simultaneously. Separate the power system or coordinate all the breakers according to the system's priority levels.

1-6. Unit Installation

- Consult your local distributor or a qualified technician to carry out installation of the unit. Installation by an unqualified person may result in water leakage, electric shock, or fire.
- Your local distributor or a qualified technician must carefully read the Installation Manual that is provided with each unit before carrying out installation work.
- Ensure there is adequate space around each unit's installation site.

1-7. Optional Accessories

- Only use accessories recommended by Mitsubishi Electric. Consult your local distributor or a qualified technician for installation. Installation by an unqualified person may result in water leakage, electric shock, or fire.
- Some optional accessories may not be compatible with the unit to be used, or may not be suitable for the installation conditions. Check the compatibility when considering any accessories.
- Note that some optional accessories may affect the unit's external appearance, weight, operating sound and other performance characteristics.

1-8. Operation/Maintenance

- Read the Instruction Book provided with each unit carefully before use.
- Maintenance or cleaning of each unit may be risky and therefore may require expertise. Refer to the Instruction Book to ensure safety. Consult your local distributor or a qualified technician when special expertise is required (such as when the indoor unit requires cleaning).

2. Precautions for Indoor Unit

2-1. Operating environment

- The refrigerant (R410A) used for air conditioners is non-toxic and nonflammable. However, if the refrigerant leaks, the oxygen level may drop to harmful levels. If the air conditioner is installed in a small room, measures must be taken to prevent the refrigerant concentration from exceeding the safety limit even if the refrigerant should leak.
- If the units operate in the cooling mode at the humidity above 80%, condensation may collect and drip from the indoor units.

2-2. Unit Characteristics

- The return air temperature displayed on the remote controller may differ from the ones on the other thermometers.
- The clock on the remote controller may be displayed with a time lag of approximately one minute every month.
- The temperature using a built-in temperature sensor on the remote controller may differ from the actual room temperature due to the effect of the wall temperature.
- Use a built-in thermostat on the remote controller or a separately-sold thermostat when indoor units installed on or in the ceiling operate the automatic cooling/heating switchover.
- The room temperature may rise drastically due to Thermo OFF in the places where the air conditioning load is large such as computer rooms.
- Be sure to use a regular filter. If an irregular filter is installed, the unit may not operate properly, and the operation noise may increase.
- The room temperature may rise over the preset temperature in the environment where the heating air conditioning load is small.

2-3. Unit Installation

- For simultaneous cooling/heating operation type air conditioners (R2, WR2 series), the G-type BC controller cannot be connected to the 16HP outdoor unit model or above, and the G- and GA-type BC controllers cannot be connected to the 28HP model or above. The GB- and HB-type BC controllers (sub) cannot be connected to the outdoor unit directly, and be sure to use them with GA- and HA-type BC controllers (main).
- The insulation for low pressure pipe between the BC controller and outdoor unit shall be at least 20 mm thick. If the unit is installed on the top floor or in a high-temperature, high-humidity environment, thicker insulation may be necessary.
- Do not have any branching points on the downstream of the refrigerant pipe header.
- When a field-supplied external thermistor is installed or when a device for the demand control is used, abnormal stops of the unit or damage of the electromagnetic contactor may occur. Consult your local distributor for details.
- When indoor units operate a fresh air intake, install a filter in the duct (field-supplied) to remove the dust from the air.
- The 4-way or 2-way Airflow Ceiling Cassette Type units that have an outside air inlet can be connected to the duct, but need a booster fan to be installed at site. Refer to the chapter "Indoor Unit" in the Data Book for the available range for fresh air intake volume.
- Operating fresh air intake on the indoor unit may increase the sound pressure level.

3. Precautions for Fresh Air Intake Type Indoor Unit

3-1. Usage

- This unit mainly handles the outside air load, and is not designed to maintain the room temperature. Install other air conditioners for handling the air conditioning load in the room.

3-2. Unit Characteristics

- This unit cannot perform the drying operation. The unit will continue the fan operation and blow fresh air (air that is not air-conditioned) when the Heating Thermo-OFF or Cooling Thermo-OFF mode is selected.
- The fan may stop tentatively when the unit is connected to the simultaneous cooling/heating operation type outdoor unit (R2, WR2 series) or during the defrost cycle.
- This unit switches the Thermo ON or OFF depending on the room temperature. The outside air is directly supplied into the room during Thermo OFF. Take caution of the cold supply air due to low outside air temperature and of condensation in the room due to high humidity of the outside air.
- Outside air temperature ranges for the operation must be as follows:
Cooling: 21°C D.B./15.5°C W.B. ~ 43°C D.B./35°C W.B.
Heating: -10°C D.B. ~ 20°C D.B.
The unit is forced to operate Thermo OFF (fan operation) when the outside air temperature is as follows.
Cooling: 21°C D.B. or below; Heating: 20°C D.B. or above
- Either a remote controller (sold separately) or a remote sensor (sold separately) must be installed to monitor the room temperature.
- If only this unit is used as an indoor unit, condensation may form at the supply air grill while the unit is operated in the cooling mode. This unit cannot operate dehumidifying.
- Use the unit in the way that the airflow rate will not exceed the 110% of the rated airflow.

4. Precautions for Outdoor Unit / Heat Source Unit

4-1. Installation Environment

- Outdoor units with salt-resistant specification are recommended in coastal areas or regions subject to salt air.
- Outdoors with salt-resistant specification are still not entirely protected against all forms of corrosion. Be sure to follow the directions and precautions outlined in the Instruction Manual and Installation Manual for correct maintenance. The salt-resistant specification adheres to the guidelines published by JRAIA (JRA9002).
- Install the unit in a place where discharge airflow is unobstructed. Obstruction of airflow may result in the short-cycling of discharge air.
- Ensure proper drainage is provided around the unit base to avoid condensation and/or water build-up. Waterproof protection should be applied to the floor when installing units on rooftops.
- In regions subject to snow and ice, install the unit so that the outlet faces away from the prevailing wind direction and install a snow guard to protect the unit from snow. Refer to the installation manual for the snow guard and take care when installing to avoid the risk of corrosion to the outdoor unit. The unit should be mounted on a base approximately 50cm higher than region's average snowfall. Close the openings for pipes and wiring, as the ingress of water and small animals or insects may cause equipment damage.
- Ensure the snow guard is kept free of snowfall exceeding 50cm.
- If the unit is expected to operate continuously for extended periods at outside air temperatures of 0°C or less, it is recommended to use a base heater to prevent ice build-up on the unit base (not applicable to PUMY series).
- Provide proper protection around outdoor units in places such as schools to avoid the risk of injury.
- A cooling tower and heat source water circuit should be a closed circuit so that water is not exposed to the atmosphere. If a tank is installed to ensure the circuit has enough water, minimise the contact with outside air so that the oxygen being dissolved in the water is 1mg/L or less.
- Install a strainer (50 mesh or more is recommended) on the water pipe inlet on the heat source unit.
- Interlock the heat source unit and water circuit pump.
- Note the following to prevent frozen burst pipes when the heat source unit is installed in an area where the ambient temperature can drop to 0°C or below:
 - Keep the water circulating to prevent it from freezing when the temperature is 0°C or below.
 - If the system is to be out of use for long periods, ensure water is purged from the unit.

4-2. Circulating Water

- Check the quality of the water in the heat source unit regularly, following the guidelines published by JRAIA (JRA-GL02-1994).
- A cooling tower and heat source water circuit should be a closed circuit so that water is not exposed to the atmosphere. If a tank is installed to ensure the circuit has enough water, minimise the contact with outside air so that the oxygen being dissolved in the water is 1mg/L or less.

4-3. Unit Characteristics

- Frequently repeating the Thermo ON and OFF on the indoor unit may destabilise the operating status of the outdoor unit.

4-4. Relevant Equipment

- Provide grounding in accordance with local regulations.

5. Precautions for Control-Related Items

5-1. Product Specification

- A consultation with BDT is required before installation of the MELANS system, particularly if the electricity charge apportioning function or energy-save function is to be utilised.
- The billing calculation for the AE-200E, AE-50E, AG-150A, EB-50GU-J, GB50ADA-J and TG2000A, as well as the calculation unit is based on a unique Mitsubishi Electric method which includes backup operation. The calculation is not based on a metering method, and does not include the input power consumption, and therefore should not be used for official business purposes. Note that the electric power consumption for the air conditioner is apportioned using the ratio corresponding to the operation status (output) of each indoor unit in this calculation method.
- In the apportioned billing function for the AE-200E, AE50E, AG-150A, EB-50GU-J and GB-50ADA-J, use separate watt-hour meters for A-control units, K-control units and packaged air conditioners for City Multi systems. It is recommended that an individual watt-hour meter is used for large-capacity indoor units (with two or more addresses).
- When using the energy-saving (peak cut) function on the AE-200E, AE-50E, AG-150A, EG-50GU-J or GB-50ADA-J, note that control is performed once per minute and therefore it may take some time to notice its full effect. Take appropriate measures such as lowering the criterion value. Power consumption may exceed limits if AE-200E, AE-50E, AG-150A, EG-50GU-J or GB-50ADA-J malfunctions or stops. A back-up solution should be available if necessary.
- The controllers cannot operate when the unit is OFF (no error). Ensure the power is ON to the indoor unit when operating the controllers.
- The interlocked control function on the AE-200E, AE50E, AG-150A, EB-50GU-J, GB-50ADA-J, PAC-YG66DCA-J or PAC-YG63MCA should not be used for the control of fire prevention or security, or any situation where it is primarily responsible for the protection of people's safety. Additional protection that allows ON/OFF operation using an external switch may be required in case of failure.

5-2. Installation Environment

- Surge protection for the transmission line may be required in areas susceptible to lightning strikes.
- Receivers for wireless remote controllers may be affected by lighting within the room. Leave a space of at least 1m between lighting sources and the receiver.
- When operating the auto-elevating panel using a wired remote controller, ensure the wired remote controller is installed in an area where it is not at risk of being damaged by the descending panel. It is recommended to use a wireless remote controller designed for use with elevating panels (sold separately).
- When installing the wired remote controller (switch box), ensure the following conditions are met:
 - oThe installation surface is flat
 - oThe controller is positioned where it can detect an accurate room temperature. Install the controller in a place where:
 - it is not subject directly to a heat source (direct sunlight and indoor unit airflow will affect the accuracy of the average room temperature reading)
 - an average room temperature can be detected
 - no other wires are present near the temperature sensor
- To prevent unauthorised access, always use a security device, such as a VPN router when connecting the AE-200E, AE-50E, AG-150A, EB-50GU-J, GB50ADA-J or TG-2000A to the internet.

Maintenance Equipment

Maintenance Cycle [Note that maintenance cycle does not mean guarantee period.]

The following tables are applicable when using equipment under the conditions below.

- Normal use without frequent START/STOPS (The number of START/STOPS is assumed to be less than 6 times per hour in normal use.)
- Operating hours are assumed to be 10 hours per day/2500 hours per year

If the following conditions are met, the equipment may not be used, or the "maintenance cycle" and "replacement intervals" may be shortened.

- When equipment is used in an environment where the temperature and humidity are high or change dramatically
- When equipment is used in an environment where the power supply fluctuations (the distortion of voltage, frequency, and waveform) are large (only within the allowable range)
- When equipment is used in an environment where the unit may be subject to vibration or mechanical shock
- When equipment is used in an environment where dust, salt, toxic gases such as sulfur dioxide and hydrogen sulfide, and oil mist are present
- When equipment starts/stops frequently and operates for a long time (24-hour air conditioning operation)

Table 1. Maintenance cycle

Major components	Checking cycle	Maintenance cycle	Major components	Checking cycle	Maintenance cycle
Compressor	1 year	20,000 hours	Expansion valve	1 year	20,000 hours
Motor (Fan, Louver, drain pump)		20,000 hours	Valve (solenoid valve, four-way valve)		20,000 hours
Bearing		15,000 hours	Sensor (thermistor, presser sensor)		5 years
Electric board		25,000 hours	Drain pan		8 years
Heat exchanger		5 years			

Note1 This table shows major components. Refer to the maintenance contract for details.

Note2 This maintenance cycle shows a period in which products are expected to require no maintenance. Use this cycle for planning maintenance (budgeting the maintenance expense etc.) Checking/Maintenance cycle may be shorter than the one on this table depending on the contents of maintenance check contract.

- Sudden unpredictable accidents may occur even if a check-up is performed

Replacement Cycle of Consumable Components [Note that replacement cycle does not mean guarantee period.]

Table 2. Replacement cycle

Major components	Checking cycle	Replacement cycle
Long-life filter	1 year	5 years
High-performance filter		1 year
Fan belt		5,000 hours
Smoothing capacitor		10 years
Fuse		10 years
Crank case heater		8 years

Note1 This table shows major components. Refer to the maintenance contract for details.

Note2 This replacement cycle shows a period in which products are expected to require no replacements. Use this cycle for planning maintenance (budgeting expenses for replacing equipments etc.)

B.S. Salt Protection Specifications

City Multi VRF Outdoor Units

Name	Base material	PUHY, PURY		Surface treatment	Paint thickness	
		YLM	YLM-BS		External	Internal
		Standard	Salt damage protection			
Bottom frame	Alloyed galvanized sheet	•	•	Polyester resin coating	70μm or more	70μm or more
Front panel	Galvanized sheet	•		Polyester resin coating	15μm or more	5μm or more
			•	Polyester resin coating	85μm or more	75μm or more
Pillar	Alloyed galvanized sheet	•		Polyester resin coating	30μm or more	
			•	Polyester resin coating	70μm or more	70μm or more
Compressor cover	Galvanized sheet	•		No treatment		
	Galvanized aluminum sheet		•	Polyester resin coating	70μm or more	70μm or more
Fin guard	Steel wires	•	•	Polyethylene resin (Weather proof)	300μm or more	300μm or more
Fan guard & Drum	Plastic	•	•	Polypropylene resin (Weather proof)		
Fan	Plastic	•	•	Acrylics nitril styrene resin		
Motor	Frame; Spcc	•	•	Zinc plating filming	8μm or more	
	Shaft; S35C	•	•	Rust prevention coloured coating		
Motor support	Galvanized sheet	•		No treatment		
			•	Polyester resin coating	70μm or more	70μm or more
Heat exchanger	Aluminum plate	•		Cellulose series and urethane series resin coating	1μm or more	
(Only fin)			•	Cellulose series and urethane series resin coating	3μm or more	
Electrical parts box	Galvanized sheet	•		No treatment		
	Galvanized aluminum sheet		•	Polyester resin coating	70μm or more	
Printed circuit board	Epoxy resin	•		Polyurethane coating	10μm or more	
			•	Polyurethane coating	10μm or more	10μm or more
Screw	Steel for screws	•	•	Zinc-nickel alloy plating + Geomet filming		

CAUTION:

- 1 Do not position the outdoor in a direct sea breeze.
- 2 Don't protect the unit from rain. (Rain will clean the salt from the coil).
- 3 Install the outdoor unit level to allow condensate drainage.
- 4 Wash the outdoor unit regularly.
- 5 Repair any scratches on the panels.
- 6 Inspect regularly. Paint or change parts as required.



FM33568 / ISO 9001;2008

The Air Conditioning & Refrigeration Systems Works acquired ISO 9001 certification under Series 9000 of the International Standard Organization (ISO) based on a review of Quality management for the production of refrigeration and air conditioning equipment.

ISO Authorization System

The ISO 9000 series is a plant authorization system relating to quality management as stipulated by the ISO. ISO 9001 certifies quality management based on the "design, development, production, installation and auxiliary services" for products built at an authorized plant.



The Air Conditioning & Refrigeration Systems Works acquired environmental management system standard ISO 14001 certification.

The ISO 14000 series is a set of standards applying to environmental protection set by the International Standard Organization (ISO). Registered on March 10, 1998.

⚠ Warning

- Do not use refrigerant other than the type indicated in the manuals provided with the unit and on the nameplate.
 - Doing so may cause the unit or pipes to burst, or result in explosion or fire during use, during repair, or at the time of disposal of the unit.
 - It may also be in violation of applicable laws.
 - MITSUBISHI ELECTRIC CORPORATION cannot be held responsible for malfunctions or accidents resulting from the use of the wrong type of refrigerant.

For more information on Mitsubishi Electric Heat Pumps, please call our customer service team on **0800 784 382**



www.mitsubishi-electric.co.nz



Black Diamond Technologies

Exclusive distributor of Mitsubishi Electric products in New Zealand.

**WELLINGTON
HEAD OFFICE**

1 Parliament Street
PO Box 30772
Lower Hutt 5040

Phone (04) 560 9147
Fax (04) 560 9133

**AUCKLAND
BRANCH**

Unit 1, 4 Walls Road
PO Box 12726
Penrose, Auckland 1642

Phone (09) 526 9347
Fax (09) 526 9369

**CHRISTCHURCH
BRANCH**

44 Halwyn Drive
PO Box 16904
Hornby, Christchurch 8441

Phone (03) 341 2837
Fax (03) 341 2838